

To design a designer to design designs

G.J. Bennett

Trinity College Dublin

-
1. Introduction
 2. Historical Weaponry
 3. Outline of new program
 4. Results
 5. Conclusions
 6. Acknowledgements
 7. References

1. Introduction

The role of the engineer in industry has evolved, with today's engineering businesses seeking engineers with abilities and attributes in two broad areas - technical understanding and enabling skills. Institutions within the engineering community such as ABET, the RAE and members of the CDIO initiative have highlighted a need for new approaches to learning and teaching of engineering within our academic institutions.

A common paradigm of engineering third level education sees a first year syllabus which introduces basic engineering sciences and mathematics, proceeding in subsequent years through more applied science and discipline specific technologies, and culminating with a variety of 'capstone' courses and a substantial engineering project. In many cases the key engineering skills of synthesis, creativity, design and implementation are only really given

C.K. Simms and P.J. Prendergast (Eds.), Perspectives on Design and Bioengineering: A Festschrift in Honour of C.G. Lyons, pp. 1-10. © 2008 Trinity Centre for Bioengineering

full expression at this (late) stage.

This paper reports on the implementation of a new project based design course at first year level of an engineering degree programme. The project, carried out in groups of six, uses the design and construction of a “Mangonel”, or catapult, as its primary task. The detail of the course, the learning outcomes, and the resource overhead are presented as well as a discussion on the initial results from the programme.

The use of the word “design” is as nebulous as “engineer” is ubiquitous. The latter is readily coupled with a variety of disciplines. The lack of clarity associated with the term Engineer is mirrored by the vagaries of the word Design. Modern designers insist the term has developed from a mere noun to a verb. That to design is organic, holistic and more aligned to an experience or life style choice than to a simple product or short term end result manifesting itself as a technical drawing for example.

In the last ten years this country has seen dramatic changes to its engineering employment structure. With low “added value” manufacturing in Ireland no longer able to compete with lower wage costs in emerging economies, Irish Engineering must adapt in order to remain viable. The national strategy is to promote a Knowledge Economy. Irish Engineers must be able to “add value” to products, to be innovative and creative, to be customer and business focussed, to think globally and to work in multi-disciplinary teams with mature project management and communication skills. A Mechanical Design syllabus provides the vehicle to develop these skills, ideally through synthesis with the engineering science subjects.

Mr. Garry Lyons is an excellent designer. He is also an excellent educationalist. As a tribute to his contribution to education in the area of Engineering Design, this paper discusses course work, initiated by him, which promotes the additional skills our engineers need to help keep our economy competitive and also to help them be creative, ethical and to design for a sustainable future.

The title of this paper highlights the interplay between verb and noun. The paper discusses the design of a novel educational programme to help our engineers be better designers.

1.1. CDIO Context

In early 2000 a group of four universities applied to the Knut and Alice Wallenberg Foundation of Sweden to fund a bold venture that would reshape engineering education in the USA and Europe. This new model, called CDIO (Conceive-Design-Implement-Operate)⁽¹⁾ was to remove the

failures previously described and provide future generations of engineers with the knowledge, skills and attitudes required to assume leadership roles in the twenty first century. Since 2000 CDIO membership has spread across all continents with some 30 participating institutions. The stated goals of the CDIO initiative are to develop:

- A deep working knowledge of technical fundamentals.
- A refined ability to discover knowledge, solve problems, think about systems, and master other personal and professional attributes.
- An advanced ability to communicate and work in multidisciplinary teams.
- Skills to conceive, design, implement, and operate systems in an enterprise and societal context.

The CDIO belief is that graduating engineers should appreciate engineering processes, be able to contribute to the development of engineering products, and to do so while working in engineering organizations. The additional implicit expectation is that recent engineering graduates should be developing as whole, mature, and thoughtful individuals. Thus CDIO has the same goals as ABET⁽²⁾ (the American organisation; Accreditation Board for Engineering and Technology) and Engineers Ireland⁽³⁾ and so the publications of all three give much guidance on the methods whereby Irish teaching institutions may achieve the improvements to engineering education required by Engineers Ireland for our student base.

1.2. Benchmarking of existing programme

The School of Engineering at Trinity College Dublin presently offers a four year course in engineering leading to the award of the degrees B.A., B.A.I. The course is fully accredited by Engineers Ireland and by affiliated institutions such as I. Mech. E..

The course has two cycles, Freshman (1st and 2nd years) and Sophister (3rd and 4th years). During the Freshman cycle, students study a common set of subjects. After successful completion of the Freshman cycle each student freely chooses a discipline from one of Civil, Mechanical, Electronic or Computer Engineering, or a combination of the latter two and follows specialist topics associated with their chosen stream over the next two years.

In addition to Mathematics and the Engineering Sciences, students in their first academic year are exposed to aspects of Engineering through laboratory work, an Introduction to Engineering Course and through subjects such as Mechanics, Graphics, CAE and Electricity and Magnetism.

However, there was thought to be shortfall in project based group activity and practical engineering implementation. To address this, a new project based design course was introduced into the Junior Freshman year of the B.A.I. degree. The addition of this course to the existing curriculum was to further the objectives of developing the 'first year' in the spirit of the CDIO goals listed above.

1.3. Desired outcomes of new programme

The purpose of a design and build assignment for first year students is multifaceted. It should hopefully bring together engineering science and technologies in a way that is instructive, whilst helping the student to experience some of the pleasure that comes from the creation of a working object. For many students this may be their first experience of this aspect of the engineered world. The assignment should contain aspects of team work/leadership, science, mathematics, computation, design-thinking and manufacturing. It should be achievable within a reasonable period of time and be within the scope of the average student's capabilities. First year engineering student numbers can be high (180-200) so the assignment must not place an undue burden on an institution's resources, either human or financial. The assignment should be a valuable one for students, give them a real understanding of the 'Petroski'⁽⁴⁾ side of engineering and let them have (are we allowed to say it?!) FUN.

We all, since we threw our toys from the pram, have experienced the pleasure afforded by the skilled throwing of objects; witness the various sports, darts, javelin, skittles, cricket etc. As engineers we pride ourselves on understanding the dynamics and mathematics of trajectory for such objects. So, here might be the germ of an idea for the subject of an assignment. Thoughts of a throwing device eventually bring to mind the projectile throwing engines of ancient times, here is a 'place' we may go.

2. Historical Weaponry

It is not certain when projectile throwing engines first came into existence. Payne-Gallwey cleverly points out that the bronze doors of the palace of King Shalmanzer of Assyria (895-825BC), which carry depictions of his war campaigns and weapons of attack and defence, show no such engines⁽⁵⁾. Our first indication of their existence comes from the Bible (2 Chronicles 26:15) where we read of the accomplishments of King Uzziah (808-796BC),

And he made in Jerusalem engines, invented by cunning men, to be on the towers and upon the bulwarks, to shoot arrows and great stones withal. And his name spread far abroad; for he was

marvellously helped, till he was strong.

Diodorus⁽⁶⁾ writes that Dionysus of Syracuse, who organised an expedition against the Carthaginians (397BC), had within his ranks a genius who designed engines that cast stones and javelins. In far Eastern writings we find mention of Chinese (Mozi) and Indian (Mahashilakantaka) catapult devices from the 5th century BC onwards. And from this time until the end of the fourteenth century we find continuous mention of engines of war.

These weapons were of various types and are described by a confusion of names. To detail their development and classification is beyond the remit of this paper but the interested reader is guided to Payne-Gallwey as a suitable starting point. However, the engines may be broadly classified as three principal types: torsion driven (catapults, etc), gravity driven (trebuchets, etc) and traction powered devices using human pulling power. In the torsion machines, (figure 1), some form of propulsion or 'throwing' arm had the missile sitting in a cup or sling at one end with the other fitted into a skein of rope or hair & animal sinew. The skein was tightened by twisting it about the throwing arm to ready the weapon for use. When the throwing arm is pulled from its initial vertical stance to being near horizontal (firing position), it causes further torsion in the skein and this stored energy when released propels both arm and missile. At some point on the trajectory of the arm the balance of dynamic forces will cause the missile to take flight.

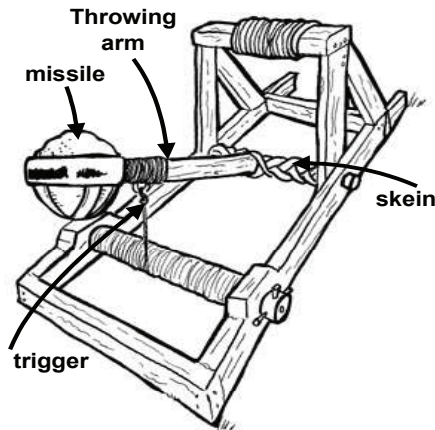

Figure 1. Torsional throwing device (taken from Payne-Gallwey⁽⁵⁾).

The velocity, mass and length of the arm all affect the velocity of the projectile, as do its weight, the stored energy of the skein and its rate of release. What then of their destructive powers; Josephus (AD 70)⁽⁷⁾, tells us that stones weighing a 'talent' (~26 kg) were thrown by the catapults for a

distance of two or more 'stadest' (say 2.5 stades, equivalent to ~400 metres). Thus these engines were of considerable destructive power.

One such device that may contain all the requirements for a student assignment is the Roman Mangonel, (figure 1). This torsion driven catapult device was among the earlier siege engines and has its origins in ancient Greece (hence *μαγγανον*, *a war engine*). The engine is constructed from relatively simple materials and is easy to model and make.

3. Outline of new program

The Mangonel Project took place over eighteen weeks with three hours on a Friday afternoon allocated in the students' timetable. As discussed, a number of departments contribute to the first two years of the B.A.I. degree. It was decided that rather than introduce individual projects each with their own emphasis, that a single project would be designed which would encompass the different engineering disciplines.

Previous works by Bennett *et al.*⁽⁸⁾, Kelly *et al.*⁽⁹⁾ and Lyons⁽¹⁰⁾ have discussed issues related to the implementation of CDIO compliant courses into engineering programmes. In each case, the dependence of success on a well designed group activity has been emphasised. In this work, in order to remain faithful to the CDIO philosophy, it was necessary that the students actually constructed something tangible which could be tested. The Mangonel, as the core object of the programme, proved itself to be extremely well suited to being at the same time a mechanical device which could be designed, manufactured, analysed and operated and also the subject to which Civil and Electronic Engineering design assignments could be associated.

The activity of the students during that three hour period varied as the year progressed;

- *Introductory lectures.* A series of introductory lectures was given towards the beginning of the programme which provided necessary foundation engineering science;
- *In class assignments/labs.* Specific tasks were set for the students on which they were to work in groups during the Friday afternoons under the guidance of demonstrators. The labs were more specific "in class assignments" but which necessitated specialised equipment and often a specific location.

Introductory lectures. To provide a basis for the technical aspects of the project a small number of lectures, see table 1, were incorporated into the programme. Each lecture was 50 minutes in duration and was delivered to the entire year. As the students would have received little in the way of formal

engineering instruction at this early stage in the degree course, the level of the lectures was introductory with an emphasis on the physical aspects of the subject matter as applied to the Mangonel. The lecture series covered subject areas such as Materials, Structures, Dynamics and Digital Electronics and were given by experts in the field.

Table 1. Introductory Lectures

No.	Discipline	Subject	Title
Lec1	General	CDIO	Conceive Design Implement and Operate.
Lec2	Mechanical/All	Modelling	The Role of Modelling in Engineering Design
Lec3	Mechanical/All	Materials	Introduction to Materials
Lec4	Civil	Structures	Why things fail
Lec5	Mechanical	Dynamics	Dynamics of the Mangonel
Lec6	Electronics	Micro-Electronics	Introduction to Digital Electronics
Lec7	Civil	Structures	Designing against structural failure
Lec8	Mechanical	Kinematics/Software Modelling	Simulation as an Analysis Tool in Engineering Design

In class assignments/labs. Detail of the class assignments is given in the following sections but, in summary, the content of the students' work during the year amounted to

- The construction of a Mangonel,
- The development of a software tool to allow the trajectory of the "missile" to be studied as a function of various operating parameters,
- A structural analysis of certain key components of the Mangonel for static and dynamic stresses using values of material properties which were experimentally determined,
- The development of a micro-electronic system to allow the angular velocity of the throwing arm to be determined.
- Testing the Mangonel.
- Redesigning the throwing arm of the Mangonel to optimise for distance without compromising its structural integrity
- An inter-group competition at the end of the year.

3.1. Mechanical and Manufacturing Engineering module

Each group of 5/6 students was issued with a kit which could be used to

assemble their own Mangonel. Within the kit was included a Bill Of Materials (BOM), assembly instructions, and parts, some of which were pre-fabricated. Due to the high number of students, time in the Mechanical workshop could not be accommodated and hence the need for pre-fabrication. However, the assembly required the use of hammers, screwdrivers, glue, G-clamps, sandpaper, matches (for fusing rope ends) and a portable drill and thus a reasonable amount of basic manufacture was incorporated despite the resource limitations.

Within the schedule of the project, the students were allowed time to assemble their Mangonel. Whilst a demonstrator was available for consultation, the students were encouraged to construct primarily from the assembly instructions. This encouraged team work and group discussion and exposed the students to a realistic manufacturing environment. In addition, the assembly instructions were complete with detailed engineering drawings of the parts. This married particularly well with drafting skills taught in a separate Junior Freshman course as the students had real parts to relate to the drawings. A fully assembled Mangonel complete with “missile” - a squash ball - is shown in figure 2(a) with a detailed image of the trigger mechanism shown in figure 2(b).



Figure 2. (a) Fully assembled Mangonel complete with “missile” - a squash ball.

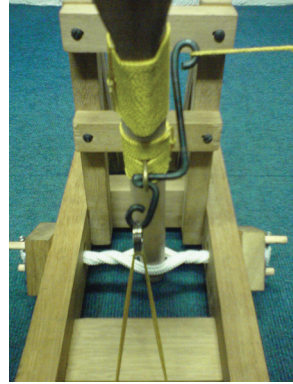

Figure 2. (b) Detailed image of the trigger mechanism

In the support lecture on Dynamics, the equations of linear motion for constant acceleration were introduced. When applied to the Mangonel these equations were developed to allow the trajectory of a missile to be modelled. The basic equations were discretized, and an associated assignment for the students was to incorporate these into an Excel spreadsheet in order to study the trajectory as a function of initial velocity and launch angle. This exercise proved to be very powerful as with effectively no programming skills the students had developed a “code” to numerically model the solution. The

subject areas of modelling, numerical methods, the concept of a time step and of a piecewise solution were subtly introduced with vector algebra applied in a useful way. The result was a design and analysis tool that the students could use.

A mathematical analysis of the equations using some basic calculus showed the optimum launch angle for the missile to be 45 degrees. The students were encouraged to verify this using their Excel model. A follow on lecture, given by the demonstrators, developed the mathematical model of the missile to incorporate drag. This allowed fundamental concepts within Fluid Mechanics to be explored in a heuristic manner. A typical output given from the Excel spreadsheet is given in Figure 3, where, for a given initial launch velocity and angle, the drag and no drag trajectories are plotted.

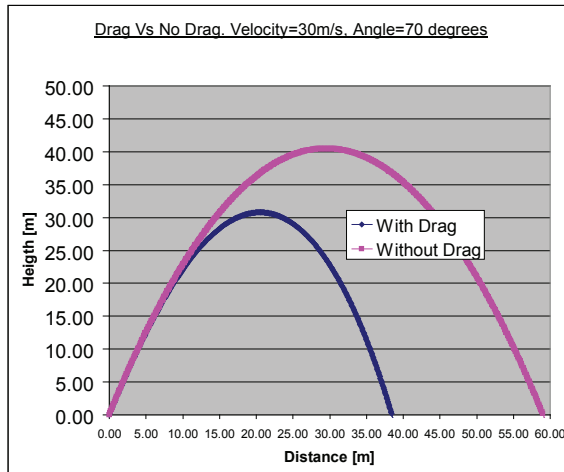

Figure 3. Missile trajectories as modelled in Excel.

3.2. Civil and Structural Engineering module

The ability to analyse and design for strength is critical to engineering design. Three preparatory support lectures were given in this area as the necessary material would not be broached until the Senior Freshman year. The first of the three lectures provides a general introduction to engineering materials theory, the second, a “show and tell” pedagogical demonstration of failure modes and the third, theory to allow structural elements of the Mangonel to be designed or analysed. Some associated labs were carried out by the students where they determined, experimentally, the failure stress of wood in bending, both statically and dynamically, as well as the failure stress of the spindle chord in tension. An additional experiment was carried out by the students where they, with the aid of a spring balance, measured the force at

the trigger ring location on the throwing arm as a function of applied torsion. With this information, and the structural theory provided, the students were able to: examine the bending stress on the throwing arm and check that the provided diameter was sufficient; examine the wooden spindle of the Mangonel for failure through shear and also determine if the spindle chord was of a sufficient diameter to sustain the maximum tension. Dynamically, the Mangonel arm was studied for its ability to withstand impact given the measured loads.

3.3. Electronic Engineering module

The electronic module of the programme was an elegant self-contained module which encapsulated the CDIO elements. In addition to the support lecture on Digital Electronics, some laboratories conducted by the demonstrators primed the students with some basic software skills. This instruction allowed the students to design code which was uploaded to flash memory on Picaxe micro-processors. The purpose was to process signals from two infra-red emitter/receiver pairs in order to derive the angular velocity of the Mangonel throwing arm. A flow chart of the steps to the solution is shown in figure 4. A pulse is generated when the arm crosses each beam. These signals are passed through some digital logic circuitry (two Nands and a JK Flip Flop) that the students design with truth tables. The resulting single high pulse is hardwired into the Picaxe which processes the signal and outputs a time to three seven segment displays. This time is used, with the geometry of the Mangonel, to determine an average angular velocity (assumed constant) of the throwing arm or a linear velocity of the missile. Each group of students had their own breadboard for the year on which they wired-up their systems, ref. figure 5.

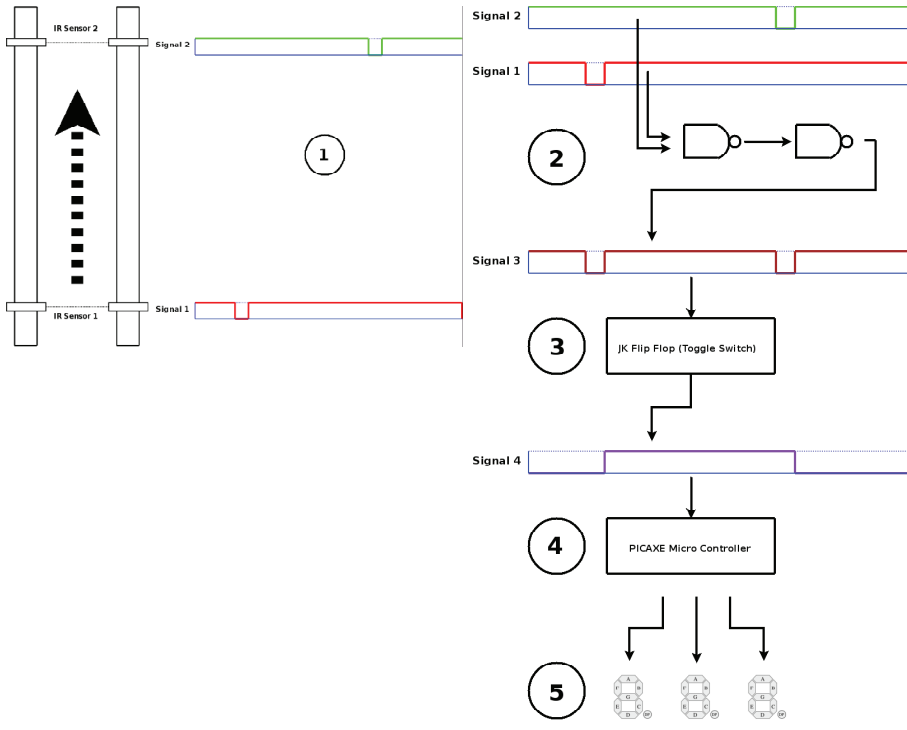

Figure 4. Flow chart of measurement circuitry.

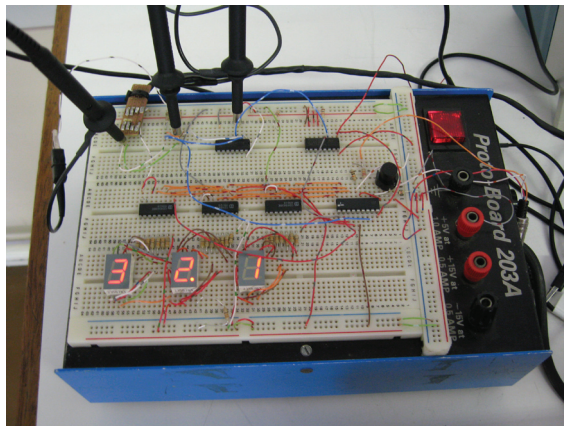

Figure 5. Functioning circuitry as designed and built by one group of students.

3.4. Testing

The students were encouraged to test their work at each stage. The functional testing of the Mangonel took place outdoors where a squash ball was the missile. By varying the diameter and weight of different squash balls, in different wind conditions, the effects of drag could be explored and its

effect on the optimum launch angle. Each team's Mangonel was tested with its own velocity measuring system, see figure 6, and the predicted distance, as calculated via the dynamic model, was used as a point of comparison with actual distance trials. Once the Mangonel, as provided, had been fully explored, the students were set the task of redesigning the throwing arm with no constraints, other than it should be optimised to maximise the throwing distance and that it should not self destruct under use. A competition was organised for the end of term and sponsorship money was attracted. The objective was to give full design control to the students where they synthesised their newly acquired skills in a fun way. The competition was covered in a special report on Science, Engineering and Technology in the Irish Times with a photograph of the competition and an interview with the winning team⁽¹¹⁾.

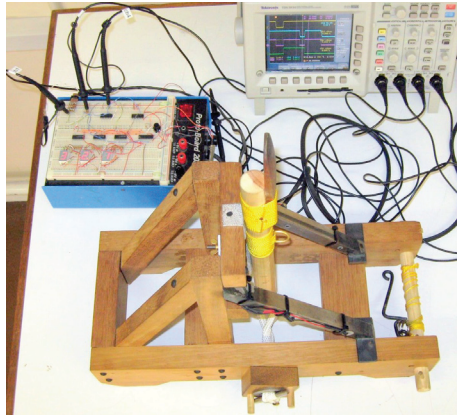

Figure 6. A students' Mangonel is tested for rotational speed with a micro-electronic measurement system that they designed and built. A metal jig holds the two infra-red emitter receiver pairs whose high/low signals are used by the logic circuitry to determine the time interval.

3.5. Evaluation

The course was run as much as possible through the Blackboard Learning System (WebCT). As the student and group numbers were large (see section 3.6), the automated functionality was convenient. Two "assignments" were set in each of the three modules. They reflected the work carried out on the Friday afternoons and if the students had participated well in their groups they should have been capable of completing the exercises. The assignments were to be completed individually, typically within three weeks, and then uploaded by the students to the dedicated website. In addition, two "assessments" were set via the website, which consisted of multiple choice questions which were

to be answered, again individually, within two hours. The software code in the Electronics' module, as well as the design of the breadboard solution, were also graded for functionality, efficiency and originality.

3.6. Resources

As no single room in the university was capable of accommodating all 180 students such they could work together in groups around a table, the students were broken into 4 streams with 9 groups per stream. Four separate locations were reserved each Friday afternoon as dedicated spaces where the group work could take place. This allowed a smaller number of students to work together and with two dedicated demonstrators (graduate students) per stream who would move between groups in a support role, the students found themselves completely removed from their normal podium based learning environment. In addition to the lecturers who contributed to the initial support lectures, a dedicated lecturer or technician from each of the three departments was involved to coordinate locally and to help specify the assignment work. Much of this effort was once off with successive years using common material. The Mangonel parts will be re-used. The project is worth 10 ECTS credits points.

4. Results

The success of a newly introduced programme is always difficult to determine as by default there is no benchmark for comparison. However, certain efforts can be made. One that was carried out here was an anonymous student survey which took place towards the end of the academic year. This was carried out by the Centre for Academic Practise and Student Learning (CAPSL) and thus was completely independent of the School of Engineering. The survey of 42 questions on a sample size of 121 students covered all aspects of the course from organisation and evaluation to content. The results were overwhelmingly positive with only one area, which was related to student feedback, being negative. This will be improved upon next year. A typical breakdown of the results is given in Figure 7. Highly encouragingly, the students were motivated to go to the labs, found the material interesting, and the key goal, were stimulated to think critically about the subject matter. This latter point is one which differentiates the failures of podium based learning from a well structured project based one. In addition to the survey, student "soundbites" were extremely positive who found the project, after a week of Mathematics and pure Engineering Science, to be more interesting and relevant to their career choice. High students numbers at the Friday

labs and a 100% turn out at the last day competition are also indicative of enthusiastic participation.

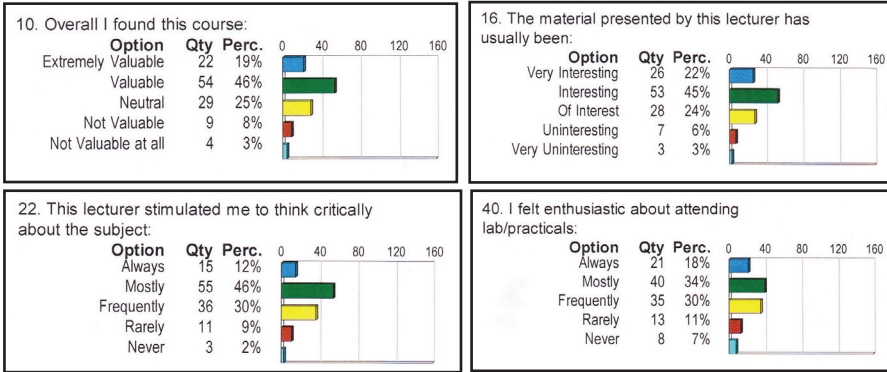

Figure 7. Sample of Results from Student Survey.

5. Conclusions

The freshman curriculum of the B.A.I. engineering degree in Trinity College Dublin has recently been revised to a more project orientated curriculum. Whilst there is a strong focus on technical content in the B.A.I. syllabus, personal skills such as communication and teamwork are considered to be an integral part of education and should continue to be fostered. The results after the first year of the introduction of a new project based course, which was inspired by the CDIO methodology, have been presented in this paper. The course successfully incorporates the three disciplines which are common to the Freshman cycle into one group based activity. The students were provided with only cursory technical fundamentals but were encouraged to think critically on their subject matter, to research independently in groups and as a result address the solutions in an innovative way in a team work environment. The course necessitated an initial investment in materials and time but this should decrease to maintenance levels from this point on. There will continue to be a requirement for a high number of demonstrator staff for the management of this course; however, the positive contribution of the course to the students' development is considered to warrant this expenditure. The direct incorporation of a drafting module into the project would be beneficial as would access to a dedicated computer laboratory capable of accommodating 50 students.

6. Acknowledgements

The author wishes to acknowledge the contribution of Mr. Kevin Kelly and Mr. Garry Lyons in the preparation of this document.

7. References

1. Conceive Design Implement and Operate (CDIO) Standards, available at: http://www.cdio.org/tools/cdio_standards.html, last retrieved April 15th 2008.
2. Accreditation Board for Engineering and Technology (ABET), available at: <http://www.abet.org/index.shtml>, last retrieved April 15th 2008.
3. Engineers Ireland, available at: <http://www.iei.ie/>, last retrieved April 15th 2008.
4. Petroski H (1996): *Invention by design: how engineers get from thought to thing*. Cambridge Mass. London, Harvard Univ Press. ISBN 0674463676
5. Payne-Gallwey R Sir (1907): *The Projectile-Throwing Engines of the Ancients*. Longman. Facsimile reprint EP Publishing 1973. ISBN 0854097767
6. Diodorus of Sicily (1933): *The Library of History. Books I-II.34. Parallel Greek text & English translation*, Originally published: 1933, Cambridge, Mass. ; London : Harvard University Press, 2004. ISBN 0674993071.
7. Josephus F (1982): *The Jewish war: newly translated with extensive commentary and archaeological background illustrations*. (G. Cornfeld, B. Mazar, P.L. Maier, Eds), Zondervan, Michigan. ISBN 0310392101.
8. Bennett GJ, Lyons G, Kelly K (2008): Implementation of a CDIO compliant syllabus in a large engineering programme. In *25th International Manufacturing Conference*, DIT, Dublin, Ireland, 3-5 September 2008 (to be published)
9. Kelly K, Lyons CG (2007): Implementing CDIO: Some Experiences and Results. In *24th International Manufacturing Conference, Waterford*, 29th-31st August 2007. (J. Phelan, Ed), pp. 209 - 220
10. Lyons CG (2005): Designing the Teaching of Engineering Design. In *IMC22- 22nd Intl Manufacturing Conference*, Dublin, 31st August-2nd Sept 2005. (J. Vickery Ed), pp. 251 – 260
11. Taking a practical approach to very ancient weaponry. *The Irish Times*, Tuesday, 20 May 2008. Special report on Science, Engineering and Technology.