

Accepted Manuscript

Title: Development of wireless bruxism monitoring device based on pressure-sensitive polymer composite

Authors: Jung Ho Kim, Padraig McAuliffe, Brian O'Connell, Dermot Diamond, King Tong Lau

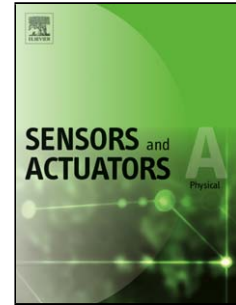

PII: S0924-4247(10)00391-2
DOI: doi:10.1016/j.sna.2010.08.033
Reference: SNA 7095

To appear in: *Sensors and Actuators A*

Received date: 22-3-2010
Revised date: 23-8-2010
Accepted date: 27-8-2010

Please cite this article as: J.H. Kim, P. McAuliffe, B. O'Connell, D. Diamond, K.T. Lau, Development of wireless bruxism monitoring device based on pressure-sensitive polymer composite, *Sensors and Actuators: A Physical* (2010), doi:10.1016/j.sna.2010.08.033

This is a PDF file of an unedited manuscript that has been accepted for publication. As a service to our customers we are providing this early version of the manuscript. The manuscript will undergo copyediting, typesetting, and review of the resulting proof before it is published in its final form. Please note that during the production process errors may be discovered which could affect the content, and all legal disclaimers that apply to the journal pertain.

Development of wireless bruxism monitoring device based on pressure-sensitive polymer composite

Jung Ho Kim^a, Padraig McAuliffe^b, Brian O'Connell^b, Dermot Diamond^a and King Tong Lau^{*a}

^aNational Centre For Sensor Research, CLARITY- centre for Sensor Web Technologies, Dublin City University, Republic of Ireland

^bSchool of Dental Science, Trinity College, Dublin, Republic of Ireland

* Corresponding author: kim.lau@dcu.ie

Tel.: +353 1 700 5273

Fax.: +353 1 700 7995

Abstract

A wireless pressure sensing bite guard has been developed for monitoring the progress of bruxism (teeth grinding during sleep); as well as protecting the teeth from damages. For sensing the pressure effectively in the restricted space and hostile environment, a pressure sensitive polymer composite has been fabricated and encapsulated into a conventional bite guard which is safe for in-situ applications. The device is anticipated to give real-time data through wireless data transmission and to have a long working life (weeks). A microcontroller-based electronic circuit has been built in-house for data collection and transmission. A low power approach is configured to increase the working life of the device. This device is a useful tool for understanding and treating bruxism.

Keywords - Bruxism, pressure sensitive polymer composite, microcontroller, wireless, bite guard, splint

1. Introduction

Bruxism

It is estimated that about 10% of the population have a bruxism which is a movement disorder of a masticatory system such as grinding of teeth and the clenching of the jaw during sleep as well as wakefulness [1-3]. Tooth clenching or grinding during sleep can result in abnormal wear patterns of the occlusal surface, fractures in teeth, morning headaches and facial muscle pain [4]. The most common management of bruxism is

based on minimizing the abrasion of tooth surfaces by the wearing of a bite-guard, or splint in the mouth [5, 6]. Currently, there is no definitive method for assessing bruxism clinically that has reasonable diagnostic and technical validity. There are also no reliable, easy to use, long-term continuous monitoring devices for bruxism available commercially.

Bruxism detection and monitoring

Evaluation of existing tooth wear does not provide evidence of current bruxism. Generally, bruxism diagnosis is to monitor masticatory muscle activity using surface electromyography (EMG) [7-9]. However, the surface EMG signal is affected by factors such as electrode position, posture and skin resistance. In addition, it is not easy to attach multiple electrodes on the face without causing unease or disrupting sleep. An alternative way to diagnose bruxism is to measure bruxism activity directly in-situ using pressure sensitive transducers. Several researchers have tried to measure sleep bruxism activity directly using an intra-oral appliance. Nishigawa et.al. [10] measured the bite force using a strain-gauge transducer incorporated a bite-guard. This device was an analogue pressure sensor with electrical wires connected out of the mouth during sleep. Takeuchi et.al. [11] proposed a pressure sensing device by using piezoelectric film-based sensor. But there was a limitation in measuring the sustained force because of the nature of the piezoelectric transducer. Some patents have been filed to diagnose bruxism through various type of splint. Abraham [12] suggested a single crude piston-switch embedded in the molded bite guard. This device had an audible alarm but did not allow monitoring or recording of the condition. Nordlander et.al. [13] patented an intra-oral acrylic splint by incorporating a piezoelectric film as a pressure sensor. However there was still no monitoring or recording function offered by this device. Another patent proposed a device which tracks the position of the jaw using an optical sensing unit. But it required an upper and lower splint, as the light emitter and the detector was separated on each splint [14]. Therefore, despite the number of techniques being developed to detect bruxism, a practical method is still not available to reliably monitor the progress of the symptom.

Wearable splint for real-time monitoring of bruxism

In this investigation, we propose a wireless intra oral pressure sensing device which will allow continuous monitoring of suspected teeth grinding over a time period to aid the diagnosis and treatment of the problem. The proposed device will have all electronic components encapsulated into the body of the bite-guard and will detect and wirelessly

transmit in real time the grinding events to a base station such as a laptop computer.

The concept envisages a carbon black-polymer composite based pressure sensor integrated into a normal prescription bite-guard. This pressure-sensitive composite has been investigated as force sensor [15-18]. M. Hussain et.al. investigated the gradual fall of resistivity with applied pressure with respect to the different sizes of silicon rubber particles and solvent [15]. Ding et.al. explained the stress relaxation and the resistance relaxation of the carbon black filled silicone rubber composite during compression [16]. The resistivity and dielectric constant of carbon-polymer composites were measured using different concentrations of carbon black and other components [17, 18]. The main advantages of polymer composite sensor are ease of fabrication, good chemical and physical stability, with high and tunable sensitivity; all of these are important for in-vivo applications. This work also makes use of recent developments in IC technologies such as the availability of low power microcontrollers and low power RF technologies which have led to the feasible and emerging of wearable sensing devices [19, 20]. It is hope that this device will identify patients with an active problem; monitor the progress of the symptoms and access the effectiveness of the treatment.

2. Experimental

The configuration of the proposed system used for monitoring activities of the bruxism is shown Figure 1. An in-house fabricated carbon polymer composite sensor is incorporated inside a bite-guard as the pressure transducer. The electronic circuit based on microcontroller drives sensor, logs data, transmits information through wireless communication and manages the power consumption. The design is configured to compose of three modules: pressure sensor incorporated bite guard with microcontroller based circuitry and wireless transmitter, RF receiver module and host computer module which are connected through the USB cable for logging data. The size of proposed device is similar to a conventional splint for teeth protection, so as to minimize the discomfort for the wearer.

2.1 Fabrication of pressure sensor

Carbon-polymer composite sensor was prepared by mixing carbon black(Alfa aesar, average particle size = $0.042\mu\text{m}$) and PDMS pre-polymer (Polydimethylsiloxane: Dowcorning, Sylgard 184) at a ratio of 17-19 wt%. The mixture was then transferred into a master mould with cavities for sensor of $7.5\text{mm} \times 4.5\text{mm} \times 0.6\text{mm}$ which was fabricated using PMMA (Poly methyl methacrylate) plate by CAD/CAM process. After

removal of bubbles by sonication, the carbon-polymer mixture was cured in an oven at 65°C for 24h.

2.2 Hardware construction

An rfPIC12F675 microcontroller (Microchip Technology Inc.) was incorporated into the bite guard to take advantage of its compact size (20 pin SSOP package: 7.85x7.20x1.85mm) and low power consumption. It is an 8 bit CMOS microcontroller with built-in UHF ASK/FSK transmitter operating at 433.92 MHz. It has 2 digital I/O channels and a 10 bit A/D converter with 4 analog inputs.

In this design, ASK (Amplitude Shift Keying) modulation is used to transmit the signal. To simplify the bite-guard design, the circuitry was configured as two parts connected via flexible cablings as shown in Figure 2. The main circuit board (on the left) includes the microcontroller and the wireless module while the second circuit board contains the I/O ports and signal conditioning function. The receiver module was designed and fabricated using a radio frequency receiver module (rfRXD420) and microcontroller (PIC12F675) from Micro Chip Inc.

2.3 Software development

Three separate software modules were developed. Firstly, the microcontroller was programmed to carry out activation, data capture and transmission functions. Secondly, the receiver module was programmed to carry out functions related to data collection, data decoding and communication with the host computer through the USB port. The third part of software was focused on displaying the incoming data and logging data with time stamping in the laptop.

2.4 System operation

The sampling rate for the pressure sensor is 8 data points/second. The device is normally put to 'sleep' mode and the microcontroller regularly checks the value from the pressure sensor. A threshold value for the sensor is set such that when the measured values fall below the threshold, it kicks start transmission of data packet at one second interval. This pre-defined threshold value is decided by calibration. Data packet is composed of ID number of each sensor and A/D value of measured resistance from pressure sensor. Specific wireless protocol was programmed for securing data. Blinking LED on the I/O circuit board provides RF power ON notification. The receiver module detects the radio signal using interrupt routine and checks the received data for errors. Then it sends one byte containing sensor ID and a second byte containing data to the PC

through the USB cable at 9600 baud rate and this module is powered by PC through USB 5V supply.

2.5 Calibration of pressure sensor and PMMA cover

Experimental setup for the compression test of the carbon-polymer sensor, PMMA cover and the combination of the two is shown in Figure 3. The conductivity of the sensor was monitored simultaneously with a Multimeter (Keithley, 2100) with sampling rate of 40Hz in room temperature.

The testing jig with cavity of 16mm(L) x 7.2mm (W) x 1mm (H) and a ridge (1mm wide) for accommodating the PMMA cover were micro milled from PMMA. A press head 4mm (d) x 1mm (h) was also fabricated for compression test. Copper tapes were attached on bottom of cavity and on the PMMA cover as contacts for the carbon-polymer sensor. There are 4 alignment pins on test jig to guide the longitudinal movement. The testing jig with sensor and cover was placed in the compression test instrument (Zwick, 5kN) and load was applied repeatedly under controlled speed (1mm/min).

The PMMA bite guard was prepared using standard dental procedure. The bite guard was configured to have two sensor cavities (one on each side corresponding to the molar teeth area) and a cavity at the rear for incorporating the electronics and batteries. The integrated bite guard on the original mould was evaluated using compressive test instrument using the procedure described above.

3. Results and discussion

3.1 Calibration of polymer-carbon composite based pressure sensor

The results obtained from Zwick compression calibration of the polymer-carbon composite pressure sensor and the corresponding digital multi-meter resistance read outs are shown in Figure 4. The pressure sensor resistivity gradually decreased before tailing off to a plateau as it was compressed at a constant speed of 0.1 mm/min to 50% of its original thickness (1mm). During the compression, the applied force increased from 0 N to 61.8 N caused a resistance change from 67.3 kOhm to 1.6 kOhm. A linear range was observed for the first 20% compression with a high sensitivity of 2.75 kOhm per unit change of strain (% displacement). The repeatability of the sensor was demonstrated in Figure 5 where the change in response at 50% compression gave an RSD of 2.17% (n=4). The cause of the error was that the excessive compression force

led to polymer hysteresis. This can be seen from Figure 5(a) and 5(b), the baseline resistivity were slightly shifted down after each compression test. The data also shows that the sensor response reached saturation at above 30% compression (corresponding to applied force of > 12 N). Hence, smaller strain is expected to improve the sensor performance and also the error margin.

3.2 Evaluation of PMMA cover

The PMMA cover for the polymer composite sensor has two important functions. Firstly, it is to protect the pressure sensor and electrical contacts from saliva and other possible substances that might appear in oral cavity. Secondly, it translates the force applied onto it to the pressure sensor during grinding events. The cover is slightly flexible, and will bend down when pressed so that the acting force is translated to displace the polymer composite sensor to cause a resistivity change. The displacement (or degree of bending) of the PMMA cover under stress is a function of its thickness; hence, a thinner cover bends more than a thick one. Therefore it is important to find out the effect of PMMA cover thickness to the responses of the pressure sensor.

Experimental results have shown that the PMMA covers can withstand 0.6 mm displacement before breaking when subject to a load of approximately 200 N. Hence, the study of cover thickness to sensor response was limited to 0.5 mm displacement which translates to 50% strain of the polymer sensor.

Figure 6 shows the relationship between thicknesses of PMMA cover and measured normal force from compressive test instrument to evaluate the mechanical property of cover to be used. As PMMA covers of thicknesses with 0.83mm~1.06mm thick (17.6mm (L) x 8.6mm (W)) were gradually compressed to reach 0.5 mm displacement, the polymer sensor gave similar response profiles in all cases, indicating that the sensor responded to the actual displacement it experienced instead of the load exerted by the compressive test instrument. It was noted that the sensor response observed was similar to that of the 50% compression of the sensor alone without the cover; the results clearly demonstrated that the PMMA cover served as excellent stress transducer for the polymer based pressure sensor which accurately measured the displacement of the cover. Hence, it can indirectly measure the actual load (force) exerted.

As we can expect, the thickness of cover determined the displacement in such a way that higher force is required to bend a thicker material to reach a particular displacement. Among the covers tested, the thickest cover (1.06mm) required a load of 132 N to give 50% compression of the sensor; this particular cover thickness is considered to be

sufficient for measuring bruxism in normal circumstances.

3.3 The autonomous wireless pressure sensing bite-guard

The fully integrated wireless pressure sensitive bite-guard is shown in Figure 7. All electronics were sealed into the plastic device by bonding (glue) method so that the entire structure was water tight.

The device is normally set to 'live' measuring mode, which can be turned off by putting into the docking station where a magnet is fitted to switch off the device. Once lifted off the station the device is active in 'stand by' mode. The current draw of standby mode is 0.76mA with the microcontroller constantly checking if the threshold resistance value was exceeded. During operation, when the preset threshold value is exceeded, the sensor logs the data and starts to transmit data (A/D value) in real time. The sampling rate can be tuned; typically 1 Hz transmission rate is used. The peak current at this rate is 11mA (Figure 8a). Figure 8b shows the voltage drop during a continuous measurement trial transmission run of ~115 hours (appr. 5 days). The silver oxide battery (SR43, 1.55V) used has a capacity of 120 mAh; in this application we used 2 batteries to achieved this prolong experiment.

Since the bite guard can be turned off while not in use with the magnetic switch; the real working life time of the device would be much longer considering RF transmission is only in use during the grinding event and the total duration of bruxism per night is normally less than 30 minutes, we therefore envisage this device to last for several months.

The working range of wireless communication is up to 100 meters in the line of sight which is sufficient for domestic usage. So the patient could locate the host computer anywhere in the house.

3.4 In vitro compressive test of the integrated wireless bruxism monitoring device

Zwick evaluation of the complete integrated wireless bite guard was performed using a speed of 1 mm/min with a preset maximum loading of 200N. The sensor response received wirelessly from sensor was plotted and presented in Figure 9.

In this experiment, the device gave a response range of 169.2 unit over a loading range from 0- 200N which effected 0.7 mm displacement of the cover. The repeatability of the device was demonstrated over 5 consecutive compressing tests, which gave an RSD of 3.79%, indicating that it is consistent enough for monitoring real life grinding.

Different pressing positions were also investigated, i.e. 4mm from the center of the cover (corresponding to similar shift of pressing position of sensor as well) under same

loading condition. A reduced sensitivity to ~100 unit change with 0.5 mm displacement was observed as expected due to the shortening of the effective length of the cover. In light of this, it is very difficult to predict the actual grinding force in practice, because the point of contact is not controllable during a grinding event, hence the same force may produce different sensor outputs depending on the location of the compression. However, the device has demonstrated sufficient sensitivity to detect the occurrence and the length of an event. Figure 10 is the cyclic loading and unloading of the pressure sensing bite guard obtained with Zwick instrument. The results clearly show reproducible performance during the three consecutive loading/unloading experiments using applied force cycling between 0 – 100 N. No significant sensor drift was observed and this confirms the robustness of the device as pressure sensor for field deployment.

Response time of the pressure sensor was measured as 300 ms with 40 Hz sampling rate, but in order to save the power consumption of the device, microcontroller was programmed for 4Hz of sampling and wireless transmission when all components are integrated into the device. This sampling rate is suitable for recording events of bruxism due to low frequency in signal.

3.5 In vivo test of the integrated wireless bruxism monitoring device

The wireless bite-guard was worn by a volunteer subject to demonstrate the practicality of monitoring grinding activity in real time. Figure 11 shows the results of the trial experiment where the subject performed random clenching activities for a period of 10 minutes. It can be seen that instantaneous clenching actions can be detected successfully owing to the fast response of the device. It was noted that when intentional clenching of individual side was performed, the biting actions recorded from the two pressure sensors located in left and right side of the bite-guard were clearly distinguishable from each other.

This wireless tooth grinding monitor is maintenance free and is a suitable tool for monitoring bruxism. Our data suggest that the sensor device is mechanically strong but flexible enough to be bended by compressive force normally exerted during a grinding event. The polymer sensor which was incorporated inside the cover accurately translated the displacement due to the compressive force into resistivity change and reported the event in real time wirelessly. We have shown that the device has extended operation time of over 100 hr of continuous measurement, which can be projected to be over three months of use based on 0.5 hour (sensing and transmission) working time per day. Wireless transmission was working without fail in reception about 100 meters away

in the line of sight and this distance is good enough for average sized house with a few walls indoor. This device provides excellent opportunity, which has never made available before, for studying and understanding the progress of bruxism in real time for an extended period of time.

4. Conclusions

A wireless pressure sensing bite guard has been developed for detection and monitoring of the progress of bruxism. The low power electronics and wireless sensing allow long term in situ measurement without maintenance. The performance of the device has shown good promise of diagnosing and monitoring bruxism.

Acknowledgment

This work is supported by Enterprise Ireland Commercialization Funding grant code: POC-2008-0156.

References

- [1] F. Lobbezoo, J. Van Der Zaag, M. Naeije, Bruxism: its multiple causes and its effects on dental implants, *Journal of Oral Rehabilitation*, 33 (2006) 293-300.
- [2] J. Van Der Zaag, F. Lobbezoo, C.M. Visscher, H.L. Hamburger, M. Naeije, Time-variant nature of sleep bruxism outcome variables using ambulatory polysomnography: implications for recognition and therapy evaluation, *Journal of Oral Rehabilitation*, 35 (2008) 577-584.
- [3] K. Koyano, Y. Tsukiyama, R. Ichiki, T. Kuwata, Review Article: Assessment of bruxism in the clinic, *Journal of Oral Rehabilitation*, 35 (2008) 495-508.
- [4] T.T.T. Dao, G.J. Lavigne, Oral Splints: The Crutches For Temporomandibular Disorders and Bruxism?, *Crit Rev Oral Biol Med*, 9 (1998) 345-361.
- [5] T.J. Dylina, A common sense approach to splint therapy, *The Journal of Prosthetic Dentistry*, 86 (2001) 539-545.
- [6] C.R. Macedo, A.B. Silva, M.A. Machado, H. Saconato, G.F. Prado, Occlusal splints for treating sleep bruxism (tooth grinding), *Cochrane Database of Systematic Reviews*, Issue 4, JohnWiley & Sons, Ltd, 2008, pp. 1-23.
- [7] G.Z. Reding, H. Zepelin, J.E. Robinson, S.O. Zimmerman, V.H. Smith, Nocturnal teeth grinding: all-night psycho-physiologic studies, *Journal of Dental Research*, 47 (1968) 786-797.
- [8] W.K. Solberg, J.D. Rugh, The use of biofeedback devices in the treatment of

- bruxism, *Journal of California Dental Association*, 40 (1972) 852-853.
- [9] G.J. Lavigne, P.H. Romp, J.Y. Monstplaisir, Sleep bruxism: validity of clinical diagnosis criteria in a controlled polysomnographic study, *Journal of Dental Research*, 75 (1996) 546-552.
- [10] K. Nishigawa, E. Bando, M. Nakano, Quantitative study of bite force during sleep associated bruxism, *Journal of Oral Rehabilitation*, 28 (2001) 485-491.
- [11] H. Takeuchi, T. Ikeda, G.T. Clark, A piezoelectric film-based intrasplint detection method for bruxism, *The Journal of Prosthetic Dentistry*, 86 (2001) 195-202.
- [12] J.G. Abraham, Pressure sensitive mouth piece, *U.S. Patent 4 979 516*, December 25, 1990.
- [13] J.Y. Nordlander, L.J. Gallia, Method and apparatus for sensing and treating bruxism, *U.S. Patent 5 078 153*, January 7, 1992.
- [14] J.D. Summer, E. Bodegom, A. Lee, Intra-oral jaw tracking device, *U.S. Patent 5 989 023*, November 23, 1999.
- [15] M. Hussain, Y.H. Choa, K. Nihara, Fabrication process and electrical behavior of novel pressure-sensitive composites, *Composites: Part A*, 32 (2001) 1689-1696.
- [16] T. Ding, L. Wang, P. Wang, Change in electrical resistance of carbon-black-filled silicone rubber composite during compression, *Journal of Polymer Science: Part B*, 45 (2007) 2700-2706.
- [17] M. Narkis, A. Ram, F. Flasner, Electrical properties of carbon black filled polyethylene, *Polymer Engineering Science*, 18 (1978) 649-653.
- [18] K. Miyasaka, K. Watanabe, E. Tojima, H. Aida, M. Sumita, K. Ishikawa, Electrical conductivity of carbon-polymer composites as a function of carbon contents, *Journal of Mater Sci*, 17 (1982) 1610-1616.
- [19] S. Choi, J. Jiang, A novel wearable sensor device with conductive fabric and PVDF film for monitoring cardiorespiratory signal, *Sensors and Actuators A*, 128 (2006) 317-326.
- [20] C.N. Chien, H.W. Hsu, J.K. Jang, C.L. Rau, F.S. Jaw, Microcontroller-based wirelee recorder for biomedical signals, *Proc. IEEE Engineering in Medicine and Biology Conf.*, 5 (2005) 5179-5181.

Jung Ho Kim received the M.S. degree in automation and design engineering and the Ph.D. degree in mechanical engineering from the Korea Advanced Institute of Science and Technology (KAIST), Daejeon, in 1996 and 2004, respectively.

He was with Samsung Electronics Co. as a Research Engineer from 1996 to 1999.

He is currently senior research staff of Adaptive Sensor Group in the National Center for Sensor Research (NCSR), Dublin City University, Ireland, since 2006.

His research interests are lab-on-a-chip, microfluidics, biosensors including personal health monitoring.

Padraig McAuliffe graduated as a dentist from NUI (Cork) in 2002. Having subsequently completed 2 years of general professional training in dentistry between Ireland and Wales, he worked in private practice in Dublin for 3 years. In 2007 he commenced a clinical doctorate in Advanced Prosthodontics at the School of Dental Science, Trinity College Dublin and is now in his final year. His research interests include facial pain and its management, sleep bruxism and how technology can be integrated into everyday clinical dental practice to improve efficiency and patient outcomes. He is particularly interested in continuous monitoring of common dental conditions and has worked on collaborative research in this field.

Brian O'Connell received his first degree in dentistry at the National University of Ireland and a PhD at the University of Rochester, New York. He worked at the NIH, Maryland where he was Chief of the Gene Regulation & Expression Unit, NIDCR. He is currently Professor of Restorative Dentistry and Director of Postgraduate Prosthodontics at Trinity College, Dublin; he is a Diplomate of the American Board of Prosthodontics. Prof. O'Connell is an investigator in the Trinity Centre for Bioengineering with an interest in bone biology and remote monitoring of oral diseases.

Dermot Diamond received his Ph.D. and D.Sc. from Queen's University Belfast (Chemical Sensors, 1987, Internet Scale Sensing, 2002), and was VP for Research at Dublin City University (2002-2004). He has published over 200 peer-reviewed papers in international journals, is a named inventor in 13 patents, and is co-author and editor of three books. He is currently director of the National Centre for Sensor Research (www.ncsr.ie) at Dublin City University, and a Principle Investigator in CLARITY (www.clarity-centre.com/), a major research initiative focused on wireless sensor networks. In 2002 he was awarded the inaugural silver medal for Sensor Research by the Royal Society of Chemistry, London and in 2006 he received the DCU President's

Award for research excellence. Details of his research can be found at www.dcu.ie/chemistry/asg.

Kim Lau received his Ph.D. from Birkbeck College, University of London (Biochemical sensors 2002). He has published over 60 peer-reviewed papers in international journals, is a named inventor in 10 patents. Dr Lau was awarded the DCU Research Fellow 2007-2009. He is currently the Beaufort Scientist at Dublin City University, associate lecturer in School of chemical and biological studies and visiting professor of NorthEastern University of China, School of Chemistry. Dr. Lau is the co-founder of the China-Ireland Centre for Advanced Materials and Sensor Development in Northeastern University that includes members from 4 universities from china and DCU. His research interests include materials research, sensors and biosensors, low-cost sensing platform development for environmental and healthcare applications.

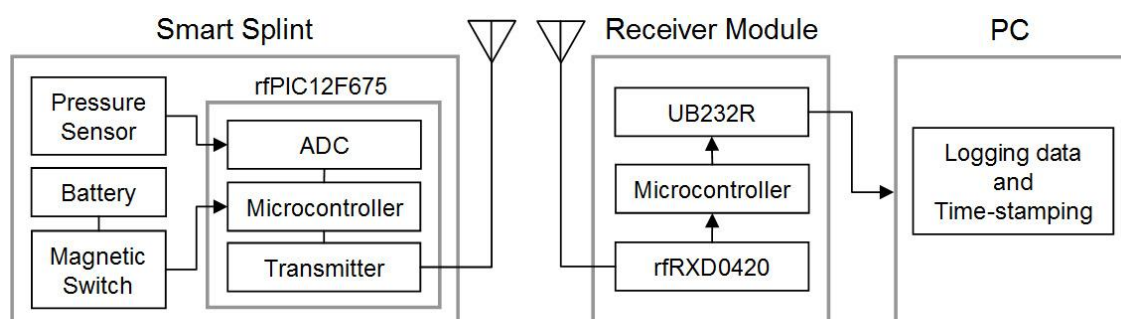

Fig. 1. Configuration of the proposed system for monitoring activities of the bruxism.

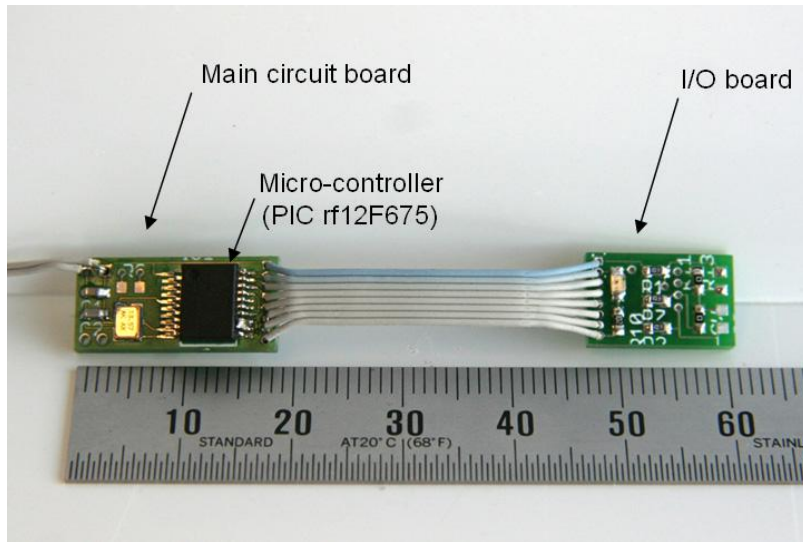

Fig.2. Photograph of fabricated microcontroller board and I/O board.

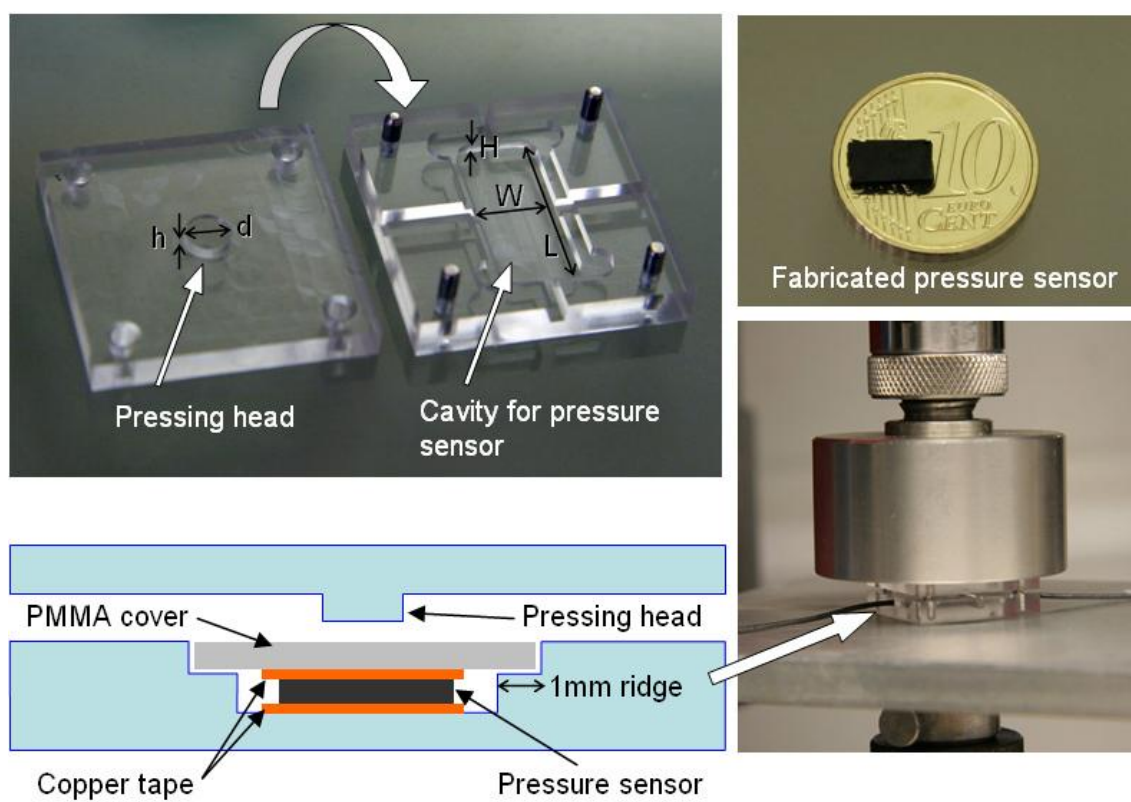

Fig. 3. Compression test for measuring the conductivity of the pressure sensor using compressive test instrument.

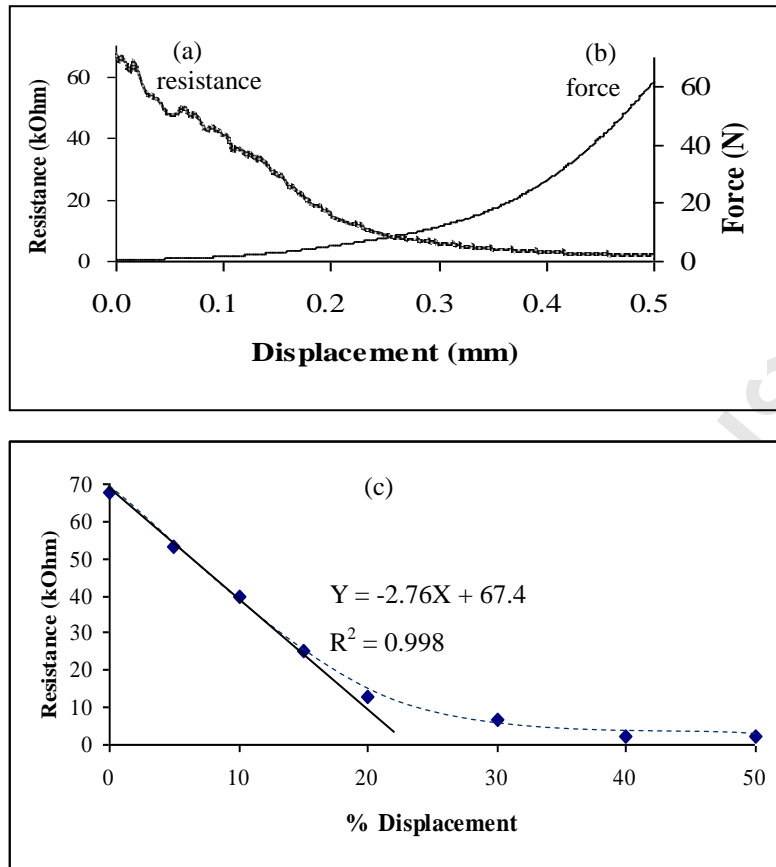

Fig. 4. (a) Resistance vs. time plot obtained simultaneously with (b) Zwick loading-displacement calibration of carbon-polymer composite sensor. (c) resistance vs. displacement plot obtained from (a) and (b).

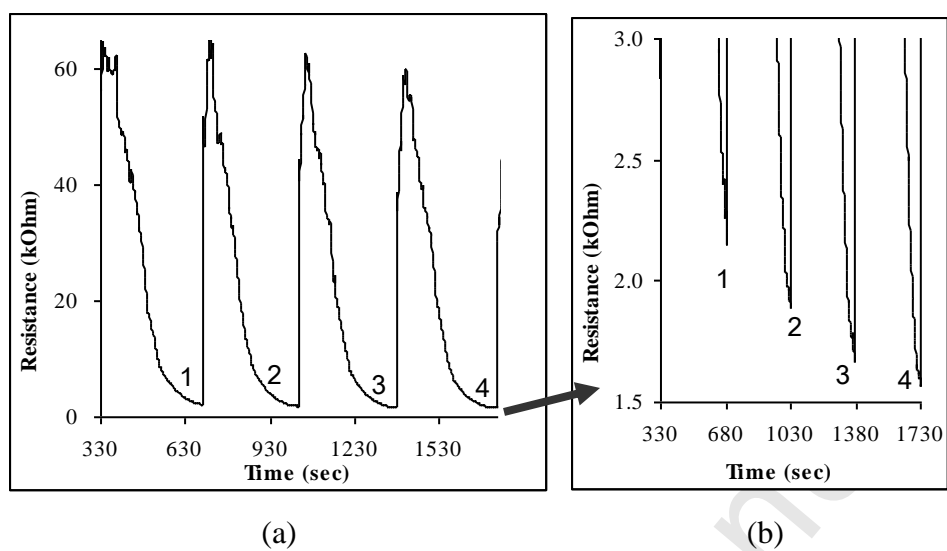

Fig. 5. Compressive test showing the repeatability of the pressure sensor. (Test speed: 0.1mm/min)

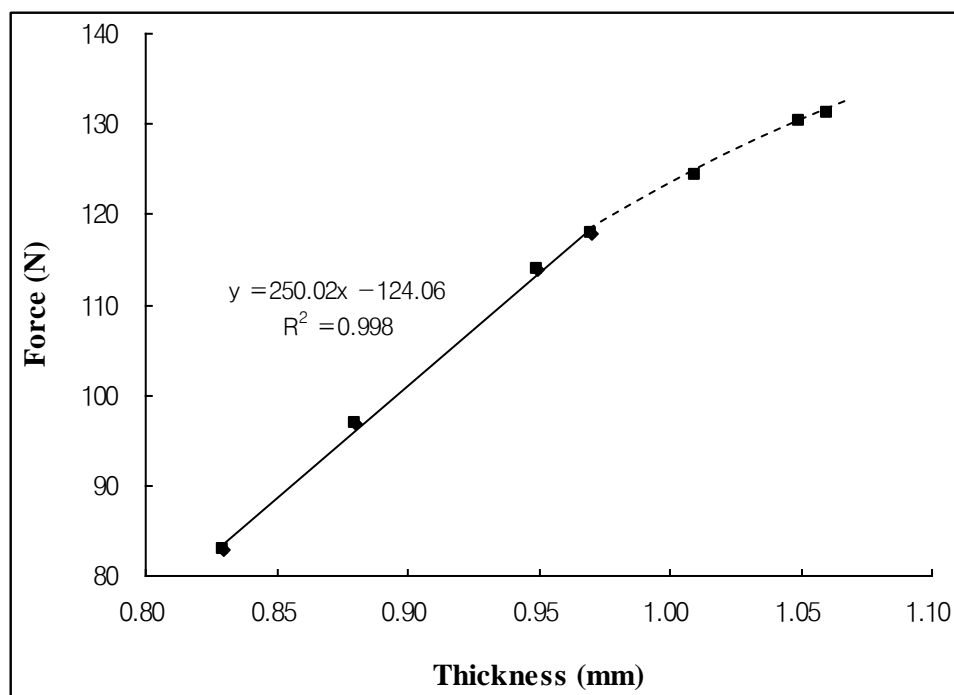

Fig. 6. Force-thickness curve with different thicknesses of acrylic cover.

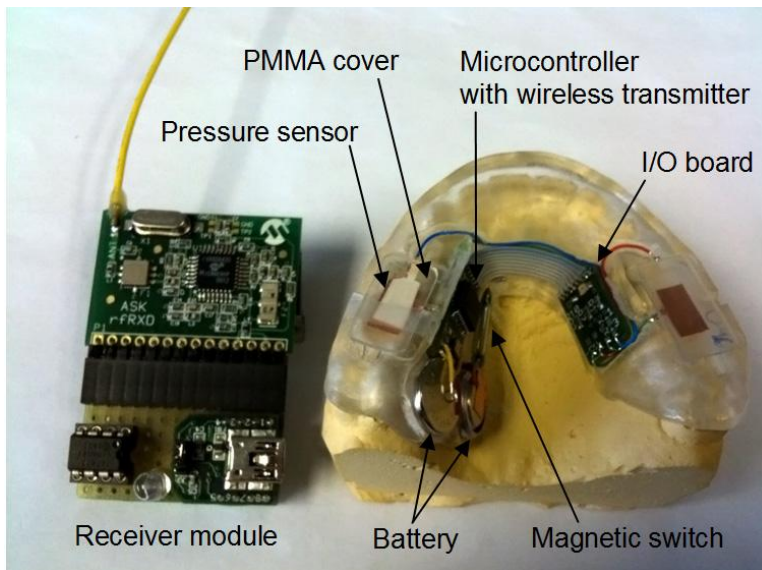

Fig. 7. Microcontroller circuit boards with pressure sensor fully integrated into the hard acrylic bite guard.

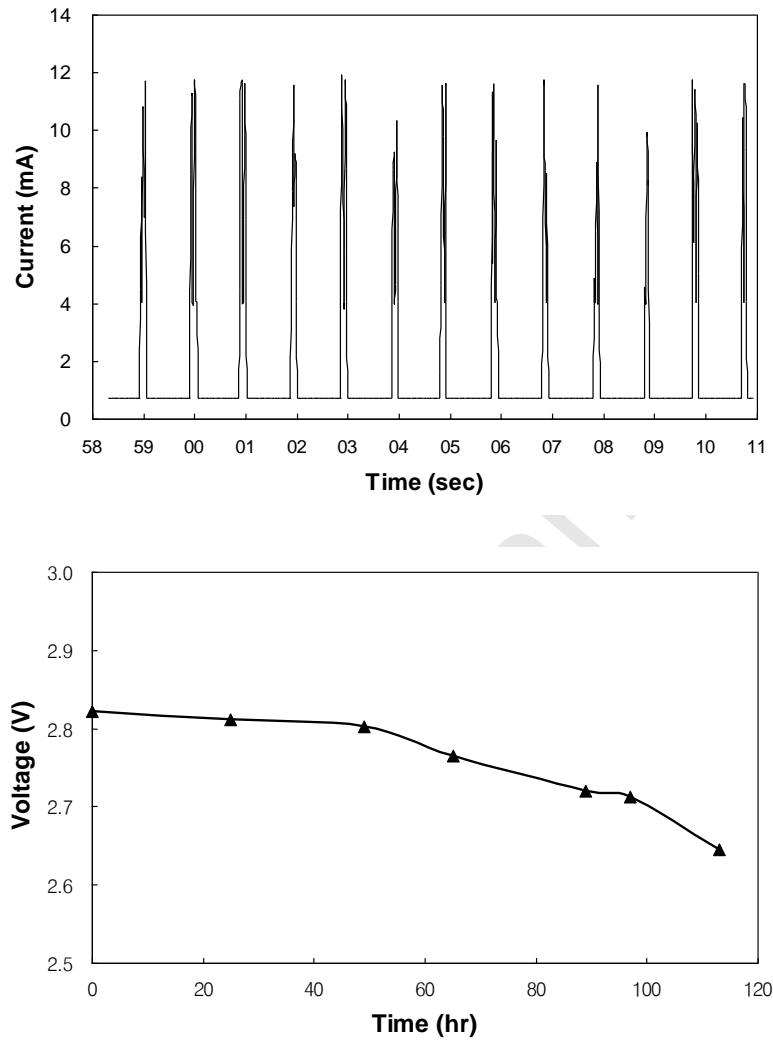

Fig. 8. (a) The current draw of microcontroller in transmitter module: Transmitting frequency = 1Hz (b) Voltage drop of battery during operation.

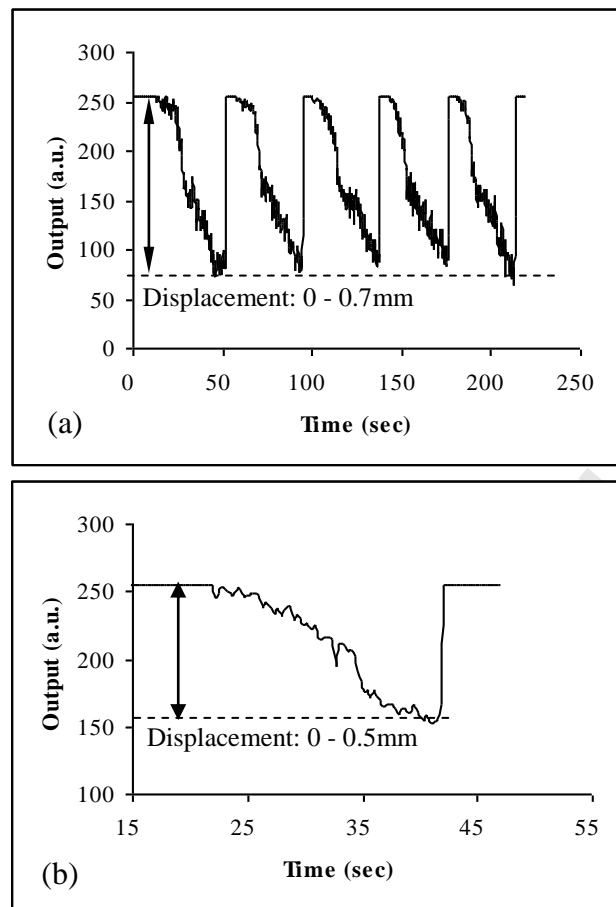

Fig. 9. Real-time response trace during a repeated compression test using Zwick instrument. Speed: 1 mm/min, maximum loading: 200N. (a) Pressing head at the center of the cover. (b) Pressing head 4mm away from the center of the cover.

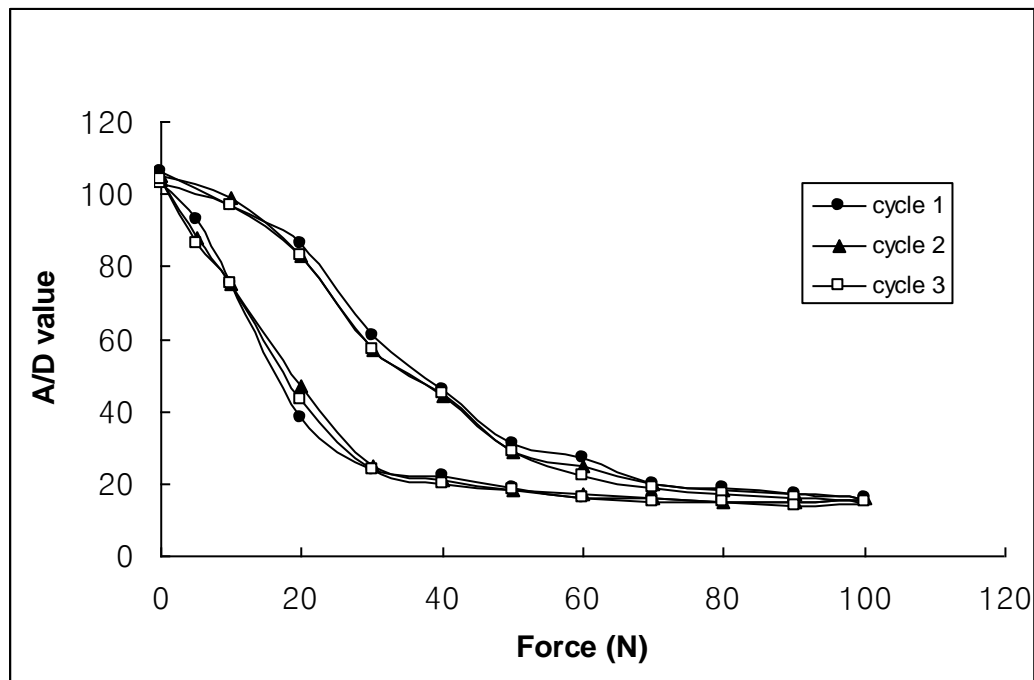

Fig. 10. Cyclic loading and unloading of the pressure sensing bite guard.

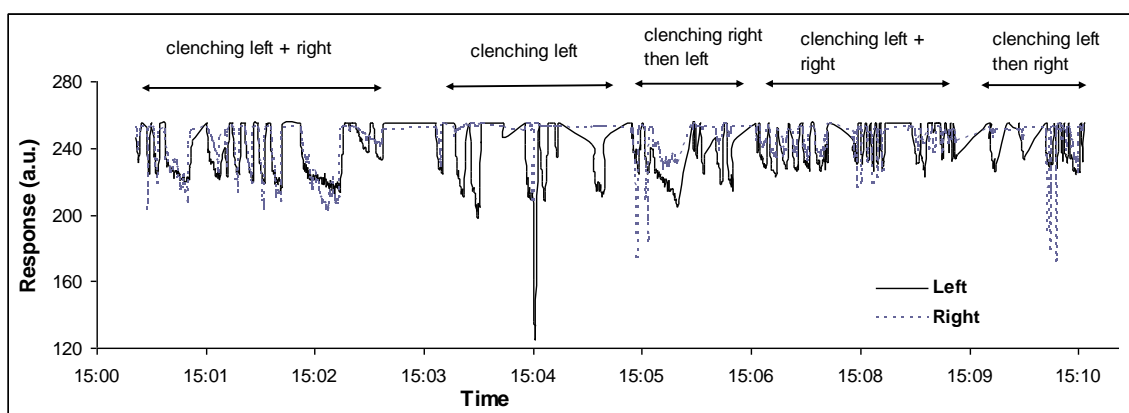

Fig. 11. Real-time clenching profile obtained from in-vivo testing of the wireless bite-guard.

- Fig. 1. Configuration of the proposed system for monitoring activities of the bruxism.
- Fig. 2. Photograph of fabricated microcontroller board and I/O board.
- Fig. 3. Compression test for measuring the conductivity of the pressure sensor using compressive test instrument.
- Fig. 4. (a) Resistance vs. time plot obtained simultaneously with (b) Zwick loading-displacement calibration of carbon-polymer composite sensor. (c) resistance vs. displacement plot obtained from (a) and (b).
- Fig. 5. Compressive test showing the repeatability of the pressure sensor. (Test speed: 0.1mm/min)
- Fig. 6. Force-thickness curve with different thicknesses of acrylic cover.
- Fig. 7. Microcontroller circuit boards with pressure sensor fully integrated into the hard acrylic bite guard.
- Fig. 8. (a) The current draw of microcontroller in transmitter module: Transmitting frequency = 1Hz (b) Voltage drop of battery during operation.
- Fig. 9. Real-time response trace during a repeated compression test using Zwick instrument. Speed: 1 mm/min, maximum loading: 200N. (a) Pressing head at the center of the cover. (b) Pressing head 4mm away from the center of the cover.
- Fig. 10. Cyclic loading and unloading of the pressure sensing bite guard.
- Fig. 11. Real-time clenching profile obtained from in-vivo testing of the wireless bite-guard.