



TRINITY COLLEGE DUBLIN
COLÁISTE NA TRÍONÓIDE, BAILE ÁTHA CLIATH

THE THERMO-HYGROMETRIC ENVIRONMENT IN CATHEDRALS IN IRELAND

Christopher Shiel

**Department of Civil, Structural and Environmental Engineering
Trinity College Dublin**

**A thesis submitted for the degree of Doctor of Philosophy to the University of Dublin,
Trinity College.**

2018

DECLARATION

I declare that this dissertation is entirely my own work, except where reference is given in the text.

This dissertation conforms to the principles and requirements of the Trinity College, Dublin guidelines for ethics in research.

The College has permission to keep, lend or copy this dissertation in whole or in part, on condition that any such use of the material from the dissertation is duly acknowledged.

Signed _____

Date _____

Abstract

Research was carried out into the often conflicting concepts of thermal comfort, conservation of artefacts and preservation of the 57 active cathedral buildings on the island of Ireland. Whilst the use to which these buildings are put is, uniquely, largely unchanged over the centuries, namely the holding of religious services, the comfort which people expect when using the buildings has changed substantially. Making the internal environment comfortable for people to be in, often means that the internal temperature and relative humidity levels, are such as to be actually damaging to the artefacts and contents of the building and to the buildings themselves. If temperature and relative humidity levels are set at a level which protects the buildings and their contents this often results in the people inside the buildings, in Ireland, feeling uncomfortably cold. The need for thermal comfort and the need to conserve and preserve the buildings and their contents cannot be reconciled and compromise must be reached if the buildings are to remain relevant and used whilst at the same time be preserved for the enjoyment and enlightenment of future generations. There is also an overall requirement to make these buildings and those similar to them to be as environmentally sustainable as possible without destroying their character or the important place which they hold in the history of Ireland. There is also the obvious imperative for the owners of these buildings and indeed for all buildings, to reduce their green-house gas emissions and carbon footprint.

A body of research exists in this area of conflict for heritage type buildings, including churches, in both the United Kingdom and continental Europe. However, a review showed that similar research had not been carried out in Ireland, where a number of factors concerning these buildings are unique, such as history, climate, size of the buildings, the number of the buildings and the artefacts contained within them. Unusually cathedrals in Ireland were largely built for purpose and not as status symbols for their sponsors and a relatively large number were built within a short period. By considering cathedrals in Ireland rather than the almost 4,000 churches, it was possible to place realistic limitations around the research whilst at the same time achieving the academic objectives. Much of the research which applies to cathedrals in Ireland will also apply to churches and similar heritage type buildings which contain large internal, undivided, spaces.

The research was divided into three principal phases. Phase one was to visit all of the 57 actively used cathedrals in Ireland in order to discover as much relevant information about them as possible. These visits, during which a comprehensive questionnaire was answered, provided information about their locations, method of construction, usage, heating systems, numbers using the buildings and other facts. For a variety of reasons which are discussed, not all of the desired information was known or available for each building.

Phase two involved monitoring a representative sample of 25 cathedrals whereby the internal and external temperature and relative humidity were recorded for at least a month during the heating

season. In addition, three cathedrals were monitored when the heating was off, to determine the internal response time to external changes in the environment during both the winter and summer months. Over 2.4m readings were taken so that it was possible to compare and contrast the various cathedrals and their differing uses and heating solutions.

Phase three comprised an analysis of the results of the readings . These are complex buildings in terms of their construction, size, usage and their environmental envelope but often require only simple solutions to provide for their thermal comfort, conservation and preservation needs.

It was ultimately shown that there is probably no one solution which will provide the appropriate compromise between the various demands made on the buildings. Whilst the core purpose of these buildings has not changed over the centuries, that is to provide religious services, there have been additional uses to which the buildings are put, especially in recent years. This change of use of these buildings may require a more flexible solution to the heating issue, with perhaps more than one type of heating system required to be installed to cope with the varying and changing environment in the which these buildings now find themselves. Chapter 6 sets out some suggested flexible solutions.

All of the data gathered from both the questionnaires and from the data logging was new and for the first time 25 Irish cathedrals have a more accurate picture of the internal environment inside the buildings. Due to the extensive nature of the data collected, even if incomplete in places, it is felt that this data can be claimed to represent all of the cathedrals in Ireland. The findings of the research showed that there are serious management short comings in the way in which the cathedral heating systems are being run operated, for a variety of reasons. There are also deficiencies in financial reporting, collective purchasing and staff knowledge and training all of which provide opportunities for the owners of these buildings. It was also shown that almost none of the cathedrals meet current standards of thermal comfort. This lack of knowledge as well as providing opportunities for the owners of the cathedrals added significantly to the body of knowledge about Irish cathedrals.

Acknowledgements

This thesis has been a team effort and I am extremely grateful to every member of the team who made it possible and without any one of whom it is unlikely to have happened. In particular, I would like to thank Professor Dermot O'Dwyer and Professor Roger West for inviting me into the department and I really appreciate the academic risk which they took in doing so. I would like to thank my supervisor Professor Roger West for being everything that an outstanding supervisor should be. He always had time for me when I needed it and his marking and remarks were meticulous and inspiring. Truly this document could not have been produced without his constant support and guidance and I am extremely grateful to him for all of his time and help over the years.

I would like to thank Lais Carvalho for all of her help with the many computer issues which I faced and for her help in putting the document together. I am so grateful and wish her every possible success in her future studies. To the technicians in the department I would like to say thank you for your courtesy and professionalism. Nothing was ever too much trouble and I learnt so much from you all. To my brother Michael I would say a huge thank you for your constant encouragement. Richard O'Hegarty sat beside me for a number of years and answered my numerous questions with great tact and patience. I could not have asked for a better work companion. To the many people I have met in TrinityHaus and the department, thank you for being so accepting, for your fun and for the many coffee breaks and crazy discussions.

I would like to say a very sincere thank you to the many people I met in the cathedrals and who were so friendly and who helped me so much with gathering the data. These people, whom I suspect are often taken for granted, show such pride in their buildings and work so hard for them, they are an inspiration.

Finally and most importantly I would like to thank my wife Heather and my family for giving me the time and space to follow my passion. I simply cannot thank them enough.

I would like to dedicate this thesis to my parents, without whose examples of lifelong learning, hard work and commitment, I could not have started on this amazing journey.

Table of Contents

Abstract	I
Acknowledgements	III
Table of Contents	IV
Table of Figures	VII
Table of Tables.....	XIV
Table of Appendices	XV
Glossary	XVI
Acronyms.....	XVIII
1 Introduction.....	19
1.1 Context.....	19
1.2 Aim & Objectives.....	25
1.3 Thesis Layout.....	26
2 Literature Review	28
2.1 Heritage Buildings	28
2.1.1 Sustainability and heritage buildings	30
2.1.2 Thermal Comfort.....	31
2.1.3 Predicted Mean Vote	34
2.1.4 Adaptive Thermal Comfort	36
2.2 Thermal Considerations in Heritage Buildings.....	38
2.2.1 Thermal Mass.....	38
2.2.2 Heat Transfer	40
2.2.3 Building Heat Loss	41
2.3 Heating Types.....	43
2.4 Moisture.....	48
2.4.1 Moisture ingress into heritage buildings	49
2.4.2 The Psychrometric Chart.....	50
2.5 The Effects of T and RH on Buildings and their Contents	53
2.5.1 The effects of moisture on the contents of historic buildings.....	54
2.6 Conclusions	58
3 Methodology	61
3.1 Introduction	61
3.2 Selection of Instrumentation	64
3.3 Calibration.....	67
3.4 Choosing the Cathedrals to be monitored.....	70
3.5 Installation of Equipment.....	76
3.6 Analysis	77

3.7	Questionnaire	80
4	Irish Cathedral’s Details.....	82
4.1	Introduction	82
4.2	History.....	83
4.2.1	Age	83
4.2.2	Location	84
4.2.3	Size	87
4.2.4	Construction	90
4.2.5	Artefacts	98
4.2.6	Shops and Coffee Shops	102
4.3.1	Usage	103
4.3.2	Opening Hours	104
4.3.3	Numbers of Services Each Year	105
4.3.4	Numbers Attending	107
4.3	Heating.....	108
4.4.1	Heating Types	108
4.4.2	Fuel Used	113
4.4.3	Types of Boilers.....	115
4.4	Performance	118
4.5	Observations and Recommendations.....	120
5	Data Logging Results and Analysis	122
5.1	Analysis by Size	122
5.1.1	Very Large Cathedrals.....	122
	St. Patrick’s, Dublin and St. Canice’s, Kilkenny.....	124
	St. Anne’s Cathedral, Belfast and Galway Cathedral.....	136
	St. Patrick’s Cathedral, Armagh.....	144
5.1.2	Very Large Cathedrals not monitored	149
5.1.3	Key findings for very large cathedrals	149
5.2.1	Large Cathedrals	152
	St. Mary’s Pro Cathedral, Dublin	153
	St. Mary’s Cathedral, Limerick.....	158
	Assumption of the Blessed Virgin Mary Cathedral (RC), Killarney	161
	St. Mel’s Cathedral (RC), Longford	165
5.2.2	Large Cathedrals not monitored.....	170
5.2.3	Key findings for large cathedrals	170
5.3.1	Medium Cathedrals	171
	St. Mary and St. Anne’s cathedral, Cork.....	172

St. Columb’s Cathedral, Derry and St. Patrick’s (CI) Cathedral, Armagh	176
St. Peter’s Cathedral, Belfast and St. Fin Barre’s cathedral, Cork.	180
Christ Church Cathedral, Dublin	185
5.3.2 Medium Cathedrals not monitored	189
5.3.3 Key findings for medium cathedrals	191
5.4.1 Small Cathedrals.....	191
5.4.2 Monitored small CI cathedrals.....	193
5.4.3 Monitored small RC cathedrals.....	211
5.4.4 Not monitored small cathedrals	216
5.4.5 Key findings for small cathedrals	217
5.5 Gradients for differing heating regimes and types found in Irish cathedrals.....	218
5.6 Observations and Conclusions.....	222
5.6.1 Temperature	222
5.6.2 Moisture.....	223
5.6.3 Sunday Services.....	224
6 Conclusions and Recommendations.....	227
6.1 Summary of work completed.....	227
6.2 Main observations	228
6.2.1 Information	228
6.2.2 Heating systems	229
6.2.3 Fuel used	230
6.2.4 Controls.....	231
6.2.5 Maintenance	231
6.2.6 Other observations	231
6.3 Key conclusions.....	232
6.4 Achievement of Objectives	232
6.5 Recommendations for further research	234
6.6 Recommendations for cathedrals.....	235
REFERENCES.....	238

Table of Figures

Figure 2.1 - ASHRAE comfort graph illustrating recommended indoor comfort temperatures for external temperature conditions (ASHRAE, 2004)(Byrne, 2014)	32
Figure 2.2 - Stablising effect of thermal mass on internal temperature (De Saulles, 2005).....	38
Figure 2.3 - Likely rates of heat loss from a typical domestic building (Byrne, 2013)	42
Figure 2.4 - Three IR emitters located on a pew in a church. A. Under a kneeler. B . Under a seat. C. On the back of the front pew toward hands (Camuffo et al., 2010).....	47
Figure 2.5 - Psychometric chart being used to show the relationship between T and RH and used to calculate the comfort zone of a building or area (Sustainability workshop, 2017)	51
Figure 2.6 - ASHRAE Psychrometric Chart at sea level (ASHRAE, 2009)	52
Figure 2.7 - Efflorescence on an East facing, outside wall of an Irish cathedral	53
Figure 2.8 - Environmental considerations for cultural collections as set out in BSI, 2012	55
Figure 2.9 - A stained glass window, in an Irish church, showing salt damage near the tie bars	56
Figure 3.1 - Irish cathedrals categorized by size and monitored	64
Figure 3.2 - Data logger used to monitor the temperature and relative humidity in the cathedrals	65
Figure 3.3 - TinyTag Model TGP-4510. Used to monitor the temperature and relative humidity on the outside of the monitored cathedrals.....	66
Figure 3.4 - Manufacturer’s data sheet for TinyTag TGP-4500.....	67
Figure 3.5 - (a) - Testo 625 Humidity and temperature measuring device and (b) probe	68
Figure 3.6 - Environmental chamber.....	69
Figure 3.7 - Sunlight test on a data logger in Trinity College	70
Figure 3.8 - Sample graph for logger 2 in St. Patrick’s Cathedral, Dublin	78
Figure 3.9 - Sample consolidated logger graph for T in St. Patrick’s Cathedral, Dublin.....	78
Figure 3.10 - Consolidated graph showing the rate of temperature increase in °C/hr for all of the loggers in St. Peter’s cathedral, Belfast.....	80
Figure 3.11 - TinyTag readings of external temperature and relative humidity from St. Mary’s cathedral, Limerick.....	80
Figure 4.1 - Location of the 57 active cathedrals on the island of Ireland (Google Maps, 2014 for map.)	85
Figure 4.2 - Church of England and the distribution of its 42 cathedrals. (Google Maps, 2014).	86
Figure 4.3 - 1981-2010 Mean Annual Rainfall in Ireland (mm). Met Eireann.....	86
Figure 4.4 - The various plantations into Ireland with dates. Courtesy of Encylopaedia Brtiannica Inc. Copyright 1998: used with permission.....	87

Figure 4.5 - Classification of Irish Cathedrals by size. All sizes are approximate	89
Figure 4.6 - Armagh Roman Catholic cathedral showing part of the painted ceiling	91
Figure 4.7 - Armagh Roman Catholic cathedral, after Vatican II showing the altar, which has been moved from the East wall further into the nave.....	92
Figure 4.8 - St. Mel's cathedral and the position of the altar, which is some distance from the East wall.....	92
Figure 4.9 - Main Mosque, Muscat, Oman.....	93
Figure 4.10 - A stained glass window in the Decorated Gothic cathedral of Armagh.....	94
Figure 4.11 - Armagh (Roman Catholic) Cathedral.....	94
Figure 4.12 - Cobh Cathedral.....	95
Figure 4.13 - Cathedral of The Immaculate Conception, Sligo. (Photo: Sligo parish)	95
Figure 4.14 - The cathedral Church of St. Mary and St. John the Baptist (CI), Sligo (Photo: Kind permission of the Dean and Chapter)	96
Figure 4.15 - St. Fin Barre's cathedral, Cork	96
Figure 4.16 - St. Patrick's cathedral, Dublin. Photograph: Patrick Donald	97
Figure 4.17 - Mullingar cathedral. (Photo: Mullingar parish).....	97
Figure 4.18 - St. Columb's cathedral, Derry. (Photo, courtesy of Curious Ireland Ltd.)	98
Figure 4.19 - Newry Cathedral. On the left hand side it is possible to see the outside of the cathedral and on the right hand side, the interior of the building with its mosaics on the walls.....	98
Figure 4.20 - A notice board at the entrance to a cathedral (Armagh RC) showing Mass times.....	106
Figure 4.21 - Percentage of the population by religious denomination (CSO, 2011).....	108
Figure 4.22 - Breakdown of heating types in cathedrals in Ireland.....	109
Figure 4.23 - Entrance to the boiler room of St. Patrick's cathedral, Dublin	112
Figure 4.24 - Types of fuels used for heating systems in Irish cathedrals.....	113
Figure 4.25 - St. Brigid's cathedral Kildare, gas storage tank	114
Figure 4.26 - Oil storage tank beside Enniskillen cathedral	114
Figure 4.27 - Enniscorthy's boiler room and the boiler room in Down Cathedral where the names of the boilers are legible	116
Figure 4.28 - Boiler room in Enniskillen (left) and boiler room in Killarney (right)	116
Figure 4.29 - Popular make of burner but with a number of models on the same data sheet	117
Figure 5.1 Scheme of categories in which the project's data was divided and analyzed	122
Figure 5.2 Gas boilers in St. Patrick's cathedral, Dublin.....	124
Figure 5.3 - Floor plan St. Patrick's Cathedral, Dublin (CoI) with loggers and TinyTag location.....	126

Figure 5.4 Showing the readings for T from all loggers for St. Patrick's cathedral, Dublin.....	126
Figure 5.5 Readings for T for St. Canice's Cathedral (winter), Kilkenny.....	127
Figure 5.6 - Floor plan St. Canice's (winter)	128
Figure 5.7 The rate per hour increase for each logger in St. Patrick's cathedral.....	130
Figure 5.8 Rate of temp. increase per hour per logger in St. Canice's cathedral (winter).....	131
Figure 5.9 Floor plan showing the location of the loggers in St. Canice's Cathedral, Kilkenny (summer).....	131
Figure 5.10 Logger readings for St. Canice's cathedral during summer 2016	132
Figure 5.11 Logger readings for RH in St. Patrick's Cathedral, Dublin	133
Figure 5.12 RH readings for St. Canice's cathedral, winter.....	134
Figure 5.13 RH readings for St. Canice's Cathedral, summer.....	135
Figure 5.14 Cathedral of Our Lady Assumed into Heaven and St. Nicholas, Galway.....	136
Figure 5.15 - Floor plan with loggers and TinyTag location of Galway's Cathedral.	137
Figure 5.16 T readings for Galway cathedral, Galway.....	138
Figure 5.17 - Rate of temperature increase per hour in Galway cathedral	138
Figure 5.18 - Floor plan with loggers and TinyTag locations installed in St. Anne's Cathedral, Belfast.....	139
Figure 5.19 Loggers' and TinyTag T readings for St. Anne's cathedral, Belfast.....	139
Figure 5.20 Electric radiant heaters switched on in St. Anne's cathedral.....	140
Figure 5.21 - Inside of the glassed off area in St. Anne's cathedral, Belfast.....	141
Figure 5.22 Rate of temperature increase per hour in St. Anne's cathedral, Belfast	141
Figure 5.23 Loggers' readings on relative humidity in Cathedral of Our Lady Assumed into Heaven, Galway.....	142
Figure 5.24 Relative Humidity levels (%) inside and outside in St. Anne's cathedral	143
Figure 5.25 St. Patrick's (RC) cathedral's ceiling (Armagh).....	144
Figure 5.26 - Floor plan Armagh (RC) winter.....	145
Figure 5.27 T readings in St. Patrick's cathedral, Armagh (RC)	145
Figure 5.28 Rate of temperature increase per hour in St. Patrick's Cathedral, Armagh (RC)...	146
Figure 5.29 T readings indoors and outdoors in St. Patrick's Cathedral in Armagh (RC) during summer	147
Figure 5.30 Inside and outside reading on Relative Humidity (RH%) in St. Patrick's Cathedral, Armagh (RC)	148
Figure 5.31 - Floor plan St. Mary's Pro Cathedral, Dublin.....	154

Figure 5.32 - Temperature readings in St. Mary's Pro Cathedral, Dublin.....	154
Figure 5.33 - Logger 3 in Pro cathedral Dublin showing the readings from 10 th to 17 th November 2015	155
Figure 5.34 - Logger 3 in Pro cathedral for one day from 15th to 16th November 2015	155
Figure 5.35 - Rate of temperature increase per hour in St. Mary's Pro Cathedral, Dublin	156
Figure 5.36 - Loggers in St. Mary's Pro Cathedral, Dublin showing RH inside the building	157
Figure 5.37 - Floor plan with loggers location St. Mary's Cathedral, Limerick	159
Figure 5.38 - Temperature readings for St. Mary's Cathedral, Limerick	159
Figure 5.39 - Logger 4 for St. Mary's CI cathedral, Limerick from 13 to 19 January 2017	160
Figure 5.40 - Rate of temperature increase per hour in St. Mary's Cathedral, Limerick	160
Figure 5.41 - Relative Humidity readings in St. Mary's Cathedral, Limerick.....	161
Figure 5.42 - Floor plan St. Mary's Cathedral, Killarney	162
Figure 5.43 - Temperature readings (indoors and outdoors) in Assumption of the Blessed Virgin Mary cathedral, Killarney	162
Figure 5.44 - Killarney cathedral logger CS2 from January Friday 15th to Monday the 18th ...	163
Figure 5.45 - Rate of temperature increase per hour in Killarney Cathedral	164
Figure 5.46 - Relative Humidity readings in Killarney Cathedral	164
Figure 5.47 - St. Mel's cathedral after the fire in 2009	166
Figure 5.48 - St. Mel's cathedral, Longford after being rebuilt in December 2014.....	167
Figure 5.49 - Floor plan St. Mel's Cathedral, Longford.....	167
Figure 5.50 - Temperature readings indoors of St. Mel's Cathedral, Longford.....	168
Figure 5.51 - TinyTag readings for temperature and relative humidity outside St. Mel's Cathedral, Longford	168
Figure 5.52 - Rate of temperature increase per hour in St. Mel's Cathedral, Longford.....	169
Figure 5.53 - Relative Humidity readings indoors of St. Mel's Cathedral, Longford	169
Figure 5.54 - Hot air blower outlet (left) and Electric radiant heaters (right) in St. Mary's Cathedral, Cork.....	173
Figure 5.55 - Rate of temperature increase per hour in St. Mary's cathedral, Cork.....	173
Figure 5.56 - Floor Plan St. mary's and St. Anne's Cathedral, Cork	174
Figure 5.57 - Temperature readings (indoors and outdoors) in St. Mary's Cathedral, Cork	174
Figure 5.58 - St. Mary's cathedral, Cork, Logger 11, from 24 to 29 February 2016	175
Figure 5.59 - RH readings inside and outside St. Mary's Cathedral, Cork	176
Figure 5.60 - Floor plan St. Columb's cathedral, Derry.....	177

Figure 5.61 - Floor plan Armagh.....	178
Figure 5.62 - Consolidated T readings (inside and outside) for St. Columb's Cathedral, Derry	179
Figure 5.63 - Consolidated T readings for St. Patrick's Cathedral (CI) in Armagh	179
Figure 5.64 The effect of a large number of people entering the cathedral for a service on 5 December in St. Columb's cathedral, Derry (CI), when the weather was very wet.....	180
Figure 5.65 - Organ in St. Fin Barre's (CI) cathedral, Cork.....	181
Figure 5.66 - St. Fin Barre's cathedral, Cork. Trench heating.....	181
Figure 5.67 - Consolidated T readings for St. Peter's cathedral, Belfast.....	182
Figure 5.68 - Consolidated T readings for St. Fin Barre's cathedral in Cork.....	182
Figure 5.69 - Floor plan St. Peter's cathedral, Belfast.....	182
Figure 5.70 - Floor plan St. Fin Barre's cathedral, Cork.....	183
Figure 5.71 - Rate of temperature increase per hour in St. Fin Barre's Cathedral, Cork	184
Figure 5.72 - Rate of T increase per hour in Belfast St. Peter's cathedral.....	184
Figure 5.73 - Consolidated RH readings) for St. Fin Barre's Cathedral, Cork	185
Figure 5.74 - Consolidated RH readings for St. Peter's Cathedral, Belfast.....	185
Figure 5.75 - Civic offices boilers which supplied heat to Christ Church cathedral, Dublin.....	186
Figure 5.76 Christchurch cathedral, LPHW heating system with radiators and heating pipes in trenches.....	187
Figure 5.77 CCC floor plan, Dublin	187
Figure 5.78 - Consolidated internal T readings in Christ Church cathedral, Dublin in winter...	187
Figure 5.79 - TinyTag readings for Christ Church cathedral Dublin in the winter.....	188
Figure 5.80 - RH readings for Christ Church cathedral, Dublin during Winter 2015.....	189
Figure 5.81 - The two Waterford cathedrals, with one exposed (CI) on the right and the other (RC) on the left surrounded on three sides by other buildings.....	190
Figure 5.82 - New oil boilers being installed in Letterkenny cathedral.....	190
Figure 5.83 - Floor plan St. Flannan's Cathedral Killaloe.....	193
Figure 5.84 - Consolidated T readings for St. Flannan's CI cathedral (Killaloe).....	194
Figure 5.85 Killaloe cathedral rate per hour increase	194
Figure 5.86 - Consolidated RH readings for Killaloe CI cathedral.....	195
Figure 5.87 - T readings in St. Lasarian's Cathedral, Raphoe	195
Figure 5.88 - Consolidated RH readings for Raphoe CI cathedral.....	196
Figure 5.89 - Rate of temperature increase per hour in Raphoe's Cathedral.....	196
Figure 5.90 - Consolidated T readings from the loggers in Old Leighlin cathedral	197

Figure 5.91 - Floor Plan Old Leighlin Cathedral	197
Figure 5.92 - Consolidated RH readings in St. Lasarian's Cathedral, Old Leighlin	199
Figure 5.93 - The electric radiant heaters in Lismore Cathedral	199
Figure 5.94 - St. Carthage's cathedral Lismore, floor plan.	200
Figure 5.95 – Lismore cathedral showing stone floor and area of the nave usually not used..	200
Figure 5.96 - The two screens in Lismore cathedral.....	201
Figure 5.97 - Consolidated T readings in St. Cathage's cathedral, Lismore.....	201
Figure 5.98 - Rate of T increase per hour for the loggers installed in Old Leighlin Cathedral ..	202
Figure 5.99 - Rate of T increase per hour in Lismore cathedral	202
Figure 5.100 - The North transept doors in Lismore cathedral which are open every day	203
Figure 5.101 - Consolidated RH readings for St. Cathage's cathedral, Lismore	203
Figure 5.102 - Inlet and outlet grills for the hot air heating system in Enniskillen cathedral ...	204
Figure 5.103 - Enniskillen cathedral showing the balcony and flags.....	204
Figure 5.104 - Floor plan Enniskillen	205
Figure 5.105 - T inside and outside for St. Macartan's Cathedral, Enniskillen	205
Figure 5.106 - Logger CS1 in Enniskillen. From Feb. 6th to 17th 2016.....	206
Figure 5.107 - Rate of increase in T per hour for the inside loggers in Enniskillen	207
Figure 5.108 - Oil fired boiler in Enniskillen cathedral	207
Figure 5.109 - Consolidated RH readings for St. Macartan's cathedral, Enniskillen	208
Figure 5.110 - Floor plan St Brigid's Cathedral, Kildare	209
Figure 5.111 - Pipe work in St Brigid's cathedral, Kildare.....	209
Figure 5.112 - St. Brigid's cathedral, Kildare, consolidated T readings from the loggers and TinyTag.....	210
Figure 5.113 - Rate of temperature increase per hour for each logger in St. Brigid's cathedral, Kildare.....	210
Figure 5.114 - Consolidated RH readings for St. Brigid's cathedral, Kildare.....	211
Figure 5.115 - Floor plan Cathedral of the Assumption of the Blessed Virgin Mary, Carlow....	212
Figure 5.116 Carlow cathedral's consolidated T readings.....	212
Figure 5.117 - Amalgamated T readings for Calow's cathedral.....	213
Figure 5.118 - Floor Plan St. Brendan's cathedral, Loughrea	213
Figure 5.119 - Consolidated T readings for Loughrea cathedral	214
Figure 5.120 - Rate of T increase per hour of Loughrea Cathedral	214
Figure 5.121 - St. Patrick's cathedral, Skibbereen	215

Figure 5.122 - T readings (indoors and outdoors) for St. Patrick's, Skibbereen	215
Figure 5.123- - Rate of T increase per hour in Skibbereen Cathedral	216
Figure 5.124 Amalgamated RH readings for Skibbereen Cathedral (indoors and outdoors) ...	216
Figure 5.125 - Interior of Kilfenora cathedral showing box pews and one of the fireplaces....	217
Figure 5.126 - Kilfenora cathedral.....	217
Figure 5.127 - St. Patrick's cathedral, Dublin, Logger 1, from March 18 to March 24, 2015....	218
Figure 5.128 - Logger CS1 Winter in St. Patrick's cathedral, Armagh (RC). T, DW and RH readings from Oct. 31st to Nov. 2nd, 2016.....	219
Figure 5.129 - T, RH and DW readings for Logger 15 in St. Brigid's cathedral (CI), Kildare. From Jan. 2nd to 18th 2016.....	219
Figure 5.130 - Logger 10 T and RH readings for St. Columb's cathedral, Derry. Monitoring period: Nov 14 th to 22 nd 2015	220
Figure 5.131 - T and RH readings from Feb. 18 th (Thu) to 21 st (Sunday) for Logger 13 in St. Mary's cathedral, Cork.....	220
Figure 5.132 - T and RH readings for Logger 2 from (Tue) Feb. 23 rd to (Monday) 29 th 2016 in St. Fin Barre's cathedral, Cork.....	221
Figure 5.133 - Logger 20 readings for T and RH in Galway cathedral. From March 25th (Wed.) to 30th (Monday) 2015.....	221

Table of Tables

Table 1.1 Church of England Energy Audit Report (Church of England, 2012-2013)	22
Table 1.2 - CIBSE benchmark figures for ecclesiastical buildings in the UK (CIBSE, 2015).....	23
Table 2.1 - Recent research papers in relation to religious buildings and thermal comfort.....	33
Table 2.2 - Fanger's Thermal Sensation Scale.	35
Table 2.3 - ASHRAE and Bedford thermal comfort scales compared.....	35
Table 2.4 - Cathedral's building components and its U values.....	43
Table 3.1 - Specifications for the data logger Model EL-USB-2+.....	65
Table 3.2 - Testo 625 manufacturer's data sheet.....	68
Table 3.3 - List of cathedrals categorised by size	71
Table 3.4 - Monitoring dates for the 25 cathedrals.....	75
Table 3.5 - Sample calculations for producing the rate of T increase per hour	79
Table 4.1 - List of Irish cathedral pipe organs, where it was possible to obtain the info.....	100
Table 4.2 - Estimated number of services per year in each of the 57 Irish cathedrals	105
Table 4.3 – Estimated number of people attending specific Irish cathedrals per year.....	107
Table 4.4 - Comparison of good and usual practice of various operational heating systems in the UK.....	118
Table 4.5 Usage analysis for the churches.	119
Table 5.1 Very large cathedrals (greater than 30,000 m ³)	123
Table 5.2 - Large cathedrals (between 20,000 m ³ and 30,000 m ³).	153
Table 5.3 - Medium cathedrals (between 10,000 m ³ and 20,000 m ³), with age, heating type and fuel used	171
Table 5.4 Small cathedrals (smaller than 10,000 m ³).....	191
Table 5.5 - Enniskillen cathedral with details of the time taken for T to fall or rise	206
Table 5.6 - Average internal temperature on Sundays and the correspondent standard deviation for each cathedral	224
Table 5.7 - IBO recommended parameters for the protection of pipe organs	225

Table of Appendices

Table A.1 - Summary of Appendices of all monitored cathedrals.....	250
Appendix 1 – St. Patrick’s Church of Ireland Cathedral	251
Appendix 2 – St. Canice’s Church of Ireland Cathedral.....	256
Appendix 3 – St. Anne’s Church of Ireland Cathedral	265
Appendix 4 – Our Lady Assumed into Heaven and St. Nicholas Roman Catholic Cathedral	270
Appendix 5 - St. Patrick’s Roman Catholic Cathedral.....	275
Appendix 6 – St. Mary’s Pro Cathedral, Roman Catholic	286
Appendix 7 – St. Mary’s Church of Ireland Cathedral	291
Appendix 8 – Saint Mary’s Roman Catholic Cathedral.....	296
Appendix 9 – Saint Mel’s Roman Catholic Cathedral.....	301
Appendix 10 – St. Mary’s Roman Catholic Cathedral.....	306
Appendix 11 – St Columb's Church of Ireland Cathedral	311
Appendix 12 – St. Patrick’s Church of Ireland Cathedral	316
Appendix 13 - St. Peter’s Roman Catholic Cathedral	321
Appendix 14 – St. Fin Barre’s Church of Ireland Cathedral	326
Appendix 15 – The Cathedral Church of the Holy Trinity, Church of Ireland.....	331
Appendix 16 – St. Mary’s Roman Catholic Cathedral.....	341
Appendix 17 – Cathedral Church of St. Flannan, Church of Ireland.....	346
Appendix 18 – St. Eunan's Church of Ireland Cathedral	351
Appendix 19 – St. Lasarian’s Church of Ireland Cathedral	356
Appendix 20 – St. Carthage's Church of Ireland Cathedral	361
Appendix 21 – St. Macartin's Church of Ireland Cathedral	366
Appendix 22 – St. Brigid’s Church of Ireland Cathedral	371
Appendix 23 – Roman Catholic Cathedral Church of the Assumption	376
Appendix 24 – Saint Brendan’s Roman Catholic Cathedral	381
Appendix 25 – St. Patrick’s Roman Catholic Cathedral	386
Appendix 26 – Church Energy Usage Questionnaire	391
Appendix 27 – List of Active Cathedrals in Ireland	394

Glossary

Aisle	The part of the cathedral divided off by an arcade.
Altar	Located in the sanctuary, it is the central point for religious services.
Apse	The space around the altar, in the sanctuary.
Arcade	A row of arches.
Archbishop	Senior Bishop, often includes the name of the place where he is based.
Baton	A short length of wood used for fixing materials such as tiles, to a roof.
Belfry	A structure, often a tower or steeple, containing bells.
Bishop	A senior consecrated member of the clergy with oversight responsibilities.
Cathedral	A church, in which is found the Bishops seat or cathedra.
Ceiling	Internal structure, often decorative, found under the roof of a building.
Chancel	The area which includes the sanctuary, altar and choir. It is often separated from the nave, by a screen.
Chapter house	The place in a cathedral where the dean and chapter discuss business.
Choir	A collection of singers.
Clerestory	The uppermost story of the central part of the cathedral.
Columbarium	A place for the storage of human ashes, usually in urns.
Column	A free-standing shaft often supporting an arch. (Cragoe, 2008)
Crossing	Area where the nave and transepts intersect.
Data logger	Small self- powered device, for measuring temperature (T) and Relative Humidity (RH), internally.
Dean	Senior cleric in the cathedral reporting to the bishop.
Dew Point	The atmospheric temperature below which droplets of water form.
Diocese	Administrative area supervised by a bishop and often divided into parishes.
Efflorescence	Movement of salts in a porous material. When they crystallise on the wall of a building, they can leave a white residue.
Equilibrium moisture content	Moisture content at which a hygroscopic material neither accumulates or releases moisture at given T and RH levels.
Flying buttress	A free standing, external, masonry support for a wall.

Gothic	A type of architectural style common in Europe between c1150 to c1500.
Hygroscopic material	One which absorbs and releases moisture.
Nave	The central spine of a cathedral, often flanked by side aisles.
Medieval	Historic time frame from c1000 – c1500 AD.
Micro climate	Climate affecting a small local area.
Organ	Keyboard instrument played with the hands and/or feet.
Pulpit	A raised platform, from where the clergy can speak to the congregation.
Relative Humidity (RH)	The ratio between the amount of moisture in the air, at a given temperature and pressure, and the maximum amount of moisture which the air could hold, expressed as a percentage.
Reredo	Decorative screen behind the altar.
Sacristan	An employee of the church responsible for the maintenance of the church and it's grounds, a title usually used in the Roman Catholic Church in Ireland. See also Sexton.
Screen	Sometimes known as a rude screen it is an ornate wooden or stone screen which separates the nave from the chancel in mediaeval churches.
Sexton	An employee of the church responsible for the maintenance of the church and its surrounds. A title usually used in the Church of Ireland. See also Sacristan.
Spire	Pointed tower on top of a church.
Stained glass	Coloured glass within a lead frame, often painted.
Stations of the Cross	A Roman Catholic tradition where 14 small icons or paintings or sculptures are placed around the walls of a church. Each scene depicts an event on the last day of Christ's day on earth.
Transept	In a cruciform church, the areas which are at right angles to the nave, usually designated North or South.
Tinytag	Small, self-powered device for measuring T and RH, externally.
Triforium	The middle story of a Gothic cathedral, usually at aisle roof level.

Acronyms

ACS	Adaptive Comfort Standard
ASHRAE	American Society of Heating, Refrigeration and Air-Conditioning Engineers
ANSI	American National Standards Institute
BS	British Standard
BMS	Building Management System
CSO	Central Statistics Office
EMC	Equilibrium Moisture Content
EN	European Standards. European Committee for Standardisation
HPHW	High Pressure Hot Water
HVAC	Heating, Ventilation and Air-Conditioning
I.S.	Irish Standard
ISO	International Organisation for Standardisation
LPHW	Low Pressure Hot Water
MRT	Mean Radiant Temperature
NSAI	National Standards Authority of Ireland
PMV	Predicted Mean Vote
PPD	Predicted Percentage of Dissatisfied
RH	Relative Humidity (%)
T	Temperature (°C)
U Value	Measure of the heat loss of a building component

1 Introduction

1.1 Context

This is a story which started at around the time of St. Patrick's arrival in Ireland, sometime in the fifth century AD and continues to this day. It will continue into the future because cathedrals and other places of worship will find it increasingly difficult to manage their utility costs, amongst other costs, in a time of decreasing and ageing congregations and increasing costs. Not being able to manage or control these costs will result in, amongst other things, changes to the internal environment of these cathedrals as a result of increased energy costs leading to reducing thermal comfort levels. Global warming is widely accepted as a reality, and it is the phenomenon which seems to be most debated. A changing external environment will change the internal environment unless, as is shown later, cathedrals can manage, at a cost, to maintain an internal environment which is independent of the external one. It is not just the environment of religious buildings which is changing. For instance on 3 February 2017 it was announced that one of the largest Roman Catholic churches in Dublin, in Finglas West, with a seating capacity of 3,500, was to be demolished and replaced with a church with a seating capacity of 350. One of the reasons being cited for this was 'high maintenance and running costs' (Cahill, 2017). The profile of people attending church is becoming older, which, as is shown later, does not necessarily mean an increased demand in thermal comfort levels but just means that congregations are diminishing in size. The Irish Times (2016) newspaper printed extracts from a Towers Watson report commissioned by the Roman Catholic Church in Ireland which showed a reduction in Mass attendance in Ireland between 2008 and 2014 of 20% and an expected reduction between 2008 and 2030 of 47%. This applies to all mass attendance and not just those attending mass in cathedrals and only applies to mass attendance in the Republic of Ireland. Protestants in the Republic of Ireland make up only 2.9% of the population according to the 2011 census (CSO, 2011) and so a rise or fall in their numbers may not have a material effect. In Northern Ireland and according to the International Social Survey Program, Religion III (2008/9) (ISSP) and the European Social Survey (ESS8, 2016)) those Roman Catholics who attend mass at least once per week fell, as a percentage, from 70.4% in 1998 to 40.5% in 2008. In Northern Ireland in the 2011 census, 48% of the responders said that they were Protestant or had been brought up Protestant and 45% declared themselves Roman Catholic or as having been brought up as Roman Catholic (Northern Ireland Statistics and Research Agency, 2011). In addition, on 3 July 2017 as reported in the Irish Independent newspaper, the Bishop of Kerry stated that 'the regular weekend Mass and full time resident priest will soon both be a thing of the past.' (Irish Independent Newspaper, 2017). This is as a result of the reduction in the number of priests in Ireland. A reduction in the number of weekly services will have an effect on the internal thermal environment within the buildings since, as will be shown in Chapter 5, most cathedrals only turn on the heating system for services.

Many cathedrals owned by the Church of Ireland have, for financial reasons, started to use the buildings for purposes other than the holding of religious services. This has raised the thermal comfort demands in these buildings. People may be prepared and perhaps expect to feel cold whilst attending a church service, but are unlikely to accept any discomfort when they have paid to attend an event. For many years, as Silva and Henriques (2015) point out, the set points of 20°C and 50% RH were taken as standard for historic buildings and museums and yet these figures were not based on any scientific research. To achieve these figures today would almost certainly require an HVAC system which is usually not feasible from an economic point nor desirable from the buildings and content view point, in Irish cathedrals.

During the course of this research a clear distinction was observed between how the Church of Ireland uses and is prepared to allow to be used, its cathedrals, as opposed to the Roman Catholic church which is more restrictive in the ways in which it's buildings are used. The Code of Canon Law of the Roman Catholic Church (Canon 1210) states that, in relation to the use to which religious buildings can be put, 'In a sacred place only those things are to be permitted which serve to exercise or promote worship, piety and religion. Anything which is discordant with the holiness of the place is forbidden. The ordinary (the Bishop) may however, for individual cases, permit other uses, provided they are not contrary to the sacred character of the place.' (www.vatican.va).

The churches are faced with many other problems which are not part of this research but which will have an influence on these buildings in the future and which were raised by interviewees many times during visits to the cathedrals. These include the shortage of clergy, the lack of funds for the maintenance of the buildings, a lack of expertise in the running of the buildings and the general secularisation of society. However there is an increase in tourism and some of these buildings may be able to use this revenue stream to extend the life of the buildings as places of religious worship.

The story of cathedrals in Ireland is closely tied to the history of the island itself. The country and its history, often troubled, have defined the sizes, locations and types of cathedrals which are left today and, to a certain extent, the uses to which they are now put. 2017 marks 500 years since Martin Luther sent his 95 theses to the Archbishop of Mainz on 31 October 1517 and subsequently posted them on the gates of All Saints Church in Wittenberg, where he was a lecturer in theology at the university (www.irishtimes.com 2017). In so doing he set in motion a series of events which shaped the future of the Christian church throughout the world. In Ireland, the Reformation, as it became known, was largely rejected and Ireland became a centre for the Counter-Reformation, which meant that the great majority of the population remained Roman Catholic. This was not acceptable to the government in England who tried to suppress the Roman Catholic version of Christianity with increasing severity. In 1698 all of the Roman Catholic bishops were forced to leave Ireland (Galloway, 1992) and it was not until the middle 1700's that they felt confident enough to start returning and

the first Roman Catholic cathedral was built in Waterford between 1793 to 1796 with the Pro-cathedral in Dublin being started in 1815 (Galloway, 1992). The attempted suppression only ended, partially, with Catholic emancipation in 1829 and which was followed in 1869 by the disestablishment of the Church of Ireland as the state church and the removal of the requirement for all to pay taxes supporting that church (www.irishtimes.com 2017).

Whilst this may have been the start of the decline of the Church of Ireland, it may also have marked the revival of the Roman Catholic church and, in a one hundred year period, between 1800 and 1899 no less than twenty two Roman Catholic cathedrals were built in Ireland (Galloway, 1992) which was a feat not matched anywhere else in Europe. This surge in building cathedrals was a direct result of the easing of the many restrictive laws which applied to Roman Catholics in Ireland which, at that time, was still ruled from Westminster in England.

There are 3,884 churches on the island of Ireland; this number does not include church buildings which are in ruins, or which have been abandoned, of which there are many. Nor does it include ancillary buildings such as offices, residences, church halls or church schools. Some ancillary buildings are used occasionally for the holding of religious services, but these are not included in the above figures. The total number of churches is made up of 2,659 Roman Catholic churches (www.thecatholicdirectory.com), 468 Church of Ireland churches (www.ireland.anglican.org/directory), 545 Presbyterian (www.presbyterianireland.org) and 212 Methodist churches (www.irishmethodist.org).

Included in these numbers there are 57 cathedrals made up of 27 owned by the Roman Catholic Church and 30 owned by the Church of Ireland. When compared with the Church of England, which has approximately 16,000 churches of which 42 are cathedrals (The Church of England, 2017), Ireland has a relatively large number of cathedrals for the size of its population. However, many of Ireland's cathedrals, for reasons which have been explained, (namely history, cost and use), are very small by comparison and should not be compared with the likes of St. Paul's cathedral in London or any of the other iconic and very large English cathedrals, such as Lincoln and York Minster or the great Gothic cathedrals found in France and Germany.

A cathedral is a church, and it can be any church, in which is situated the bishop's throne or *cathedra*. The Greek word *kathedra*, or *cathedra* in Latin, means throne, chair or seat. The bishop is enthroned into his cathedral church on appointment as a bishop. A cathedral need not be and often is not, the largest church in an area or diocese but it is the bishop's throne which makes it a cathedral and not the size of the building. It is these Irish cathedrals which are the subject of this research although the findings could be relevantly applied to many other similar buildings.

In addition to the need to manage and maintain these buildings for future generations to enjoy and learn from, there is the obvious imperative for these buildings to reduce their carbon footprint as it is

generally acknowledged that all existing building stock, including heritage type buildings, must reduce their CO₂ emissions and so help in the fight against global warming and climate change. In September 2013, the Church of England published an Energy Audit Report 2012/13 covering its substantial property portfolio (Church of England, 2012-2013). That church has committed to cut its carbon emissions by 80% by 2050. In summary, the Church of England found that, across all types of property, the church spent approximately £124 million on energy in 2012/2013 and their total carbon footprint energy use was between 610K and 1M tons of CO₂. Churches were estimated to produce between 237K and 395K tons of this figure or 39%. 430 building owners took part in the survey. Of the contributors to total carbon emissions, small cathedrals made up 0.24% (11 of 42) of the total, medium cathedrals 1% (24 of 42) and large cathedrals 1% (7 of 42), although, those medium and large cathedrals accounted for 36% of the total carbon emitted by the church. The Church of England has 15,779 churches which make up 52% of its total property portfolio (Church of England, 2013). With regard to the 42 cathedrals in the Church of England the statistics are shown in Table 1.1.

Table 1.1 Church of England Energy Audit Report (Church of England, 2012-2013)

Category	Number of Cathedrals * ₁	% of total cathedrals * ₁	% of total buildings * ₁	Average tonnes of CO ₂ e for cathedrals * ₂	Estimated total tonnes carbon * ₃	% of estimated total CofE emissions * ₄	kWh/m ² /yr * ₅
Small (<250m ²)	11	26%	0.04%	174	1,435 - 2,393	0.23%	101
Medium (250-649m ²)	24	57%	0.08%	215	3,875 - 6,459	1%	197
Large (>649m ²)	7	17%	0.02%	911	4,783 - 7,972	1%	527
Total	42	100%	0.14%	433	10,094 - 16,824	2%	275 (average)

*₁ The number of cathedrals of each size is based on data available within the Cathedral and Church Buildings Division

*₂ These figures are based on a number of Carbon Trust reports on energy from 2008

*₃ This is a ballpark figure based on the data available from the Carbon Trust reports, +/-25% of the estimate

*₄ These percentages are based on estimated total carbon emissions for the Church of England built estate

*₅ These figures are based on data available from the Carbon Trust reports

The churches in Ireland have not yet carried out similar research, but if one were to extrapolate the Church of England figures then one can estimate, as the climate is not too dissimilar, that churches in Ireland produce approximately 155,000 tons of CO₂ per annum with cathedrals making up some 2,900 tons of this. This amounts to each cathedral in Ireland producing on average over 50 tons of CO₂ per annum. It is obviously not possible to compare the very small Kilfenora cathedral, which holds 3 services a year, with large metropolitan cathedrals in Dublin and Cork which hold over 1,000 services per year. However as cathedrals tend to be larger than most churches, it can be safely assumed that the figure will be higher than this. It is not considered accurate enough to try to extrapolate the financial energy costs in Irish churches from those in the Church of England. This is

because the English figures include buildings such as offices, church halls and schools. The Church of England was supplied with bespoke software to monitor energy use in its buildings. This was supplied by the software energy monitoring firm sMeasure, free of charge. However, this license has now expired, and the Church of England is seeking to purchase new software specifically written to cater for its unique requirements.

The sMeasure software enabled individual churches to monitor all of their energy use, including water and then to compare it to national standards, as well as enabling them to set carbon reduction budgets (Pilio, 2016). This was part of the Church of England's program called 'Shrinking the Footprint' which is an ongoing environmental awareness campaign which was launched in 2006. There is no equivalent initiative in Ireland.

In addition, the Carbon Trust which it says comprises 'Independent experts on carbon reduction and resource efficiency' surveyed 24 churches and 6 cathedrals in the UK in 2006/07 (Makrodimitri et al, 2011). It estimated that the churches in the Church of England produced approximately 212K tons of CO₂ in 2006/07, a figure which is well under the Church of England audit figures of 2012. Whether this is because different methods of measurement were used or because there had been a substantial decrease in the amount of CO₂ produced is not known. Individual cathedrals differ substantially in size, construction, age, location and whether major renovations were carried out. Also they may differ markedly from a parish church, in how they are used. Many cathedrals are now major public gathering spaces and provide a number of social services which were never envisaged when they were built. Events such as concerts, degree awarding ceremonies, crèches, plays and film making are now common-place in many Irish cathedrals, although, as previously noted, Roman Catholic cathedrals are restricted to religious events only. All of this makes it very difficult to arrive at any kind of standard or representative figures for energy use and CO₂ emissions, in the absence of a national survey.

The Carbon Trust decided to use benchmarks by investigating the actual energy consumption of individual churches and then produced a Normalized Performance Indicator (NPI) for a normal church building (Makrodimitri, Campbell, & Steemers, 2011). This NPI is expressed as the annual energy consumption per square meter of floor area (kWh/m² per year).

The Chartered Institute of Building Services Engineers (CIBSE) have also produced a benchmark for ecclesiastical buildings in the United Kingdom (UK), as shown in Table 1.2.

Table 1.2 - CIBSE benchmark figures for ecclesiastical buildings in the UK (CIBSE, 2015).

	Good Practice	Typical Operation
Fossil Fuel	80 kWh/m ²	150 kWh/m ²
Electricity	10 kWh/m ²	20 kWh/m ²

The very oldest cathedrals in Ireland, as in the UK, were built with no heating system and they were not planned to include any heating. Most Church of Ireland cathedrals are situated on the sites of older monasteries and in the UK in the remains of one of the largest and finest monastic sites in Europe, namely at Fountains Abbey, it is still possible to see the remains of the two Warming Room fires where the choir monks were allowed to warm themselves for a few minutes at the end of their 2am devotions, there being no other heating in the abbey. The oldest Church of Ireland cathedrals would include St. Patrick's cathedral and Christ Church cathedral in Dublin and Down Cathedral in Downpatrick as well as St. Canice's in Kilkenny. When built in or around the 12th century there would not have been any seats for the congregation and the earliest churches might have only had earthen floors. The only people who could read were the priests and the only energy use was candles for them to read by. These were environmentally sustainable buildings. The stone and wood from which they were made was sourced locally so that transport was kept to a minimum. Where stone was brought from abroad, such as the Caen stone used in Christ Church, it was quarried near the sea and was transported by wooden boats using the wind as propulsion. Once built, the buildings were naturally ventilating and because of their thermal mass, were generally of constant temperature and relative humidity with the inside environment mirroring the outside environment but with a substantial time difference as a result of the thermal lag. However these older cathedrals were substantially renovated in the middle of the 19th century and in some cases almost rebuilt. At that time, heating was installed which usually involved a heat source such as a coal-fired boiler and with hot water, pipes and radiators. These became known as low pressure hot water systems (LPHW) (Papavasileiou, et al. 2012). Prior to this there is evidence of localized heating with stand-alone fires and fire places (Roberts and Ferris, 2008). A very few cathedrals such as Down and Killala cathedrals still have what are known as box pews where the, mostly, wealthy sat in church with their families and sometimes their dogs, beside a personalised stove.

The heating systems found in cathedrals in Ireland are almost as varied as the buildings themselves as can be seen in Appendix 27. Why they installed the systems they did and why they replaced them with the systems which they have done is largely a mixture of both cost and usage. This variation of heating types can be seen in such buildings throughout the world. Where substantial funds are available one could look at the geothermal installation in St. Patrick's cathedral in New York, which was completed in 2015 as part of a \$177 million restoration of the cathedral. This system required ten geothermal wells to be drilled to an average depth of 1,800 feet. As a spokesperson for the cathedral said 'We weren't thinking of immediate payback'. One could also consider the new underfloor system recently installed in Manchester cathedral in the UK which required the removal of the floor and the old underfloor heating system and then the complete restoration of the floor. Also in the UK Durham cathedral recently installed as part of a £10 million installation of a new

treasury exhibition, three inline condensing gas boilers provide the heating or one could consider the new multi million pound HVAC system recently installed in the Sistine Chapel in Rome. The original system was designed to cope with 700 visitors per hour at a time, but these numbers are now over 2,000 visitors an hour. This was an extremely complex installation since the original frescos by Michelangelo di Lodovico Buonarroti Simoni, commonly known as Michelangelo, could not be disturbed. The Sistine Chapel is of course not a cathedral, the cathedral church of Rome being the St. John Lateran Archbasilica, but like the building next door, namely St. Peter's Basilica, it is probably the most widely recognized Christian building in the world.

Thus, it is possible to see that many different Christian buildings throughout the world and not just in Ireland, arrive at different solutions to solve what is basically the same problem which is how to heat a building adequately without damaging the building and its contents while allowing worshipers a modicum of thermal comfort.

This introduction sets out the background and the context for the research which follows. It shows that there are many, often conflicting, issues which affect these buildings. It describes what a cathedral is and it notes the different ways in which Church of Ireland and Roman Catholic churches are used. It also gives some idea of the complexity of applying modern heating systems to heritage buildings and perhaps shows how no one solution can be applied to all of these buildings.

1.2 Aim & Objectives

The main aim of this research is to gather information about the active cathedrals in Ireland in order to make relevant observations so that firm recommendations can be made in relation to their heating and energy use.

The main objectives of this PhD research project are:

- To compile a database of each the 57 active Irish cathedrals by carrying out an onsite survey of each cathedral using a detailed questionnaire. The survey will include details of the heating systems within the buildings, the type of fuel used and how the buildings are used, amongst other details.
- To monitor the internal and external temperature and relative humidity, over a period of at least one month, in each location, of a representative sample of 25 of the 57 cathedrals in Ireland to discover details of the internal thermo-hygrometric environment in these buildings. Three of the above cathedrals will also be monitored when the heating is off to determine how quickly these buildings react naturally to changes in the outside environment in both winter and summer.

- To identify if it is possible to group cathedrals in Ireland, which are of similar size, age, usage, construction and location to deduce if a particular heating system and regime might be more or less suitable for them with regard to usage, thermal comfort, conservation and preservation.

These objectives are important because the data has not been collected and analysed before and the 25 monitored cathedrals will, for the first time, have accurate data with regard to the internal environment within the buildings and this data will be relevant for all of the cathedrals in Ireland and almost certainly to the remaining over 3,800 churches. This data will help the cathedrals when they have to make decisions regarding their heating systems and regimes.

1.3 Thesis Layout

The thesis is laid out in six chapters and, in outline, Chapters 2 to 5 have the following contents.

Chapter 2: Literature Review. This chapter sets out the extent of the existing knowledge in the area of thermal comfort and conservation and preservation of heritage type buildings and their contents, particularly cathedrals. It includes the existing knowledge-base relating specifically to cathedrals in Ireland and compares and contrasts that knowledge with that relating to cathedrals in other parts of Europe.

Chapter 3: Methodology. Using the knowledge gained in Chapter 2, this chapter sets out why particular research methods were chosen and how they were carried out. It explains why particular equipment was chosen and how and where it was placed and identifies the issues of working with listed and heritage buildings. It also explains how the questionnaire, which was used during the site visits, was compiled and used.

Chapter 4: Irish Cathedral's Details. This chapter sets out the findings of the site visits including where the cathedrals are situated, how they are constructed and how they are used. The chapter sets out what makes cathedrals in Ireland unique and highlights the differences between them and their counterparts in other parts of Europe. This chapter is based on the responses to the questionnaire.

Chapter 5: Data Logging Results and Analysis. Based on the results from the monitored cathedrals this chapter sets out individual cathedral results of temperature and relative humidity together with complete rate of temperature increase per hour data and compares and contrasts the various cathedrals. Over 2.4 million readings were analysed and discussed from the 25 cathedrals which were monitored.

Chapter 6: Conclusions and Recommendations A summary of the work done will be given and the objectives set out at the beginning of the research will be examined to establish if they have been

met and the conclusions and recommendations based on the research findings will be stated in this final chapter, together with recommendations for further research.

Contributions to knowledge

The primary contributions to the existing knowledge base concerning the issues surrounding heating of churches and cathedrals are the information obtained from the questionnaires and from the over 2.4 million pieces of data collected from the 25 monitored cathedrals. This type of data has not been collected before for Irish cathedrals, which are unique in a number of ways. The data enabled solid observations and recommendations to be made, as set out in Chapter 6.

2 Literature Review

2.1 Heritage Buildings

Irish cathedrals are heritage buildings in that they are important repositories of history, not just of the communities they serve, but also of the buildings themselves (Rodwell, 2012). The United Nations Educational, Scientific and Cultural Organisation (UNESCO, 2012) defines heritage as 'our legacy from the past, what we live with today, and what we pass on to future generations'. This seems apposite with regards to Irish cathedrals. Although the oldest ones have been altered much over the centuries they still contain elements which are hundreds of years old. Both they and the cathedrals which have been built in the last 150 years or so and which have been altered very little since they were built, 'are what we live with today' and with careful maintenance it should be possible to pass on these buildings 'to future generations'. ICOMOS, the International Cultural Tourism Committee describes heritage as 'heritage is a broad concept and includes natural as well as the cultural environment'. (ICOMOS, 2013). English Heritage (2008) describes heritage as 'all inherited sources which people value for reasons beyond mere utility'. The opening statements of the International Charter for the Conservation and Restoration of Monuments and Sites, which is more commonly known as the Venice Charter of 1964, states that 'Imbued with a message from the past, the historic monuments of generations of people remain to this present day as living witnesses of their age-old traditions.' (Rojas, 2014). Cathedrals in Ireland fit into any and all of these definitions and value characteristics.

Cathedrals are an irreplaceable part of the history of a country and this applies to Ireland as much as to any other country in spite of the relatively small size of Irish cathedrals. Ireland's often troubled history can be chronicled by the repeated destruction of its cathedrals and churches. The Church of Ireland cathedral in Armagh is a good example of this where no less than 26 burnings and sackings of the building took place between 670 and 1642 (Galloway, 1992). Cathedrals can also be repositories of invaluable historical records. Lismore cathedral still has a library attached to the nave and, until fairly recently, Cashel cathedral had a library housed in a building just beside the cathedral. This library has now been moved to more suitable premises for the protection of the books. Dr. Stuart Kinsella, the archivist in Christ Church cathedral in Dublin, described that cathedral's archives as '--- contains one of the longest continuous collections of records of any institution in Ireland' (Christ Church cathedral, 2017). In his history of Christ church cathedral Dr. Kenneth Milne (2000) gives a description of what is called the Black Book (late 13th century – early 16th century) and the White Book (late 15th century – early 16th century) which are books containing administrative details of the cathedral going back many hundreds of years. The originals of these books are kept in the Representative Church Body or head office of the Church of Ireland in Dublin. Other examples are the 'Dublin troper' which is usually ascribed to Christ Church cathedral and which is stored in Cambridge

University library, and the Bodleian library in Oxford contains what is known as the Christ Church Psalter. So it can be seen that cathedrals can be important depositories of elements of the history of Ireland. As Camuffo and Vale (2007) put it: 'Churches constitute an inestimable wealth consisting of sacred and liturgical items as well as the patrimony preserved in museums and historical buildings.'

Irish cathedrals and churches in general can be characterised as having low thermal efficiency as a result of their design and the traditional materials used to build them, such as stone, wood, slate and bricks (Varas-Muriel et al., 2014), compared these with modern buildings built of concrete, steel and glass. Few if any cathedrals have any type of damp proof course and rely instead on the thickness of their walls to prevent the ingress of water into the building (Little et al., 2015). As Little points out, the type of stone used in cathedrals can differ greatly and, depending on the density, porosity and permeability of the stone, this will determine the amount of water which can enter the building. He also points out that different types of stone can hold different amounts of water within them. It is often however the very permeability of the building envelope of these older buildings which has enabled them to be the sustainable buildings which they obviously are, and sealing them up tight to achieve some kind of passive standard would almost certainly increase the amount of interstitial and surface condensation. Unfortunately, as Bordass and Bemrose (1996) point out, many cathedrals and churches (and Irish ones are no exception), use intermittent heating with all of the moisture problems which this creates. Smith et al. (2008) discuss the effects of water and decay on the stone built cultural heritage but introduces the interesting concept of aesthetics and how people's attitude to a badly soiled building might be affected. Whether or not people would be less likely to attend a cathedral whose outside walls were badly discoloured by erosion and/or contamination, is not known.

Most of the early cathedrals had no heating installed when they were built (Makrodimitri et al. 2012) and so the internal thermal environment mirrored the external environment. Cathedrals have solid stone walls on the outside and inside, but all have rubble infill, (Rodwell, 2012) and the make-up of the rubble can sometimes be used to more accurately date the building, where the rubble is accessible.

Irish cathedrals, like most cathedrals and churches, have large open undivided spaces which are difficult and costly to heat. They usually have single glazed windows although some have secondary glazing and some have storm glazing, which in themselves if not properly ventilated can cause moisture damage (Feilden, 2003). Cathedrals have permeable envelopes which generally allow easy ingress and egress of air and moisture while in modern buildings everything is done to minimise the rate at which heat energy is exchanged internally and externally. It may be the case that this very permeability of older buildings has enabled the oldest cathedrals, those built in the 13th century for instance, to survive so well and for so long. The older Irish cathedrals, as with all cathedrals, have not

only had to withstand the introduction of heating installed into them but also have had to stand, in many cases, the increasing levels of pollution which occur especially in urban areas. Increasing levels of CO₂, Methane (CH₄), Nitrogen Oxides (NOX) and Chlorofluorocarbons (CFCs) can attack and damage the exterior and interior of buildings. Brostrom (2008) says that 'climate induced degradation is one of the major threats to historical buildings and their interiors'. Those cathedrals situated in urban areas are particularly susceptible to urban air pollution, mostly caused by transport, which can and does attack the fabric of the buildings.

2.1.1 Sustainability and heritage buildings

The Kyoto Protocol drawn up in 1997 committed countries to make substantial reductions in their carbon emissions by certain dates (UNFCCC.INT, 1997). This led to a lot of new legislation from both the European Union, such as the European Union Directive on the Energy Performance of Buildings 2002/91/EC (European Commission, 2002), and the UK government Climate Change Act (UK Government,2008). The Paris agreement United Nations Framework Convention on Climate Change, 2016 then built on this. However, to date, religious buildings in Ireland are exempt from many environmental and building regulations. There is no guarantee however that this will remain the case. The Church of England in its 'Shrinking the Footprint' Program has set ambitious carbon emission reduction targets for that church, but no church in Ireland has set similar targets specifically. The Church of England are committed to a carbon reduction figure of 80% by 2050 which is in line with UK government targets but also to a reduction of 42% by 2020. Considering that the Church of England has some 16,000 churches and 42 cathedrals these are ambitious targets (Church of England, 2012-2013). The current Archbishop of Canterbury in England, Dr. Justin Welby, has said that "The present challenges of environment and economy, of human development and global poverty, can only be faced with extraordinary Christ-liberated courage" (Church of England, 2013). With nearly four thousand churches in Ireland and 57 cathedrals it might be considered important for the churches in Ireland to be showing leadership in this area. Whilst there is currently no legal requirement on the churches in Ireland to reduce their carbon footprint, minimising their energy requirement would release funds for badly needed maintenance and other areas (Makrodimitri et al., 2011). As Christiana Figueres, the Executive Secretary of the United Nations Framework Convention on Climate Change, stated in her 2014 Commencement speech at the University of Massachusetts in Boston, ' –climate change is no longer a threat: it is your reality.' (University of Massachusetts, 2014).

The national climate policy in Ireland is set out in the National Policy Position on Climate Action and Low Carbon Development (DCCAIE, 2014) and the Climate Action and Low Carbon Development Act (DCCAIE, 2015) and they set out 'an aggregate reduction in carbon dioxide (CO₂) emissions of at least 80% (compared to 1990 levels) by 2050, across the electricity generation, built environment and

transport sectors'. In Ireland it is the Department of Communications, Climate Action and Environment which has responsibility for these matters. In Northern Ireland there is a Cross-Departmental Working Group on Climate Change (CDWG CC) under the auspices of the Department of the Environment NI which has similar responsibilities.

In relation to buildings in Ireland, there are EU regulations with regard to reduction in greenhouse gases (GHG) and the relevant one is the EU Energy Performance of Buildings Directive (EPBD) (EC, 2002) which was ratified in 2002. In Ireland this was legislated for under Statutory Instrument (SI) 243 (EHLG7 and Byrne, 2013). There are a number of exceptions and exemptions mentioned in Part 1 Section 4 of this SI and these include 'a building used as a place of worship or for the religious activities of any religion'. It is not however just about what is allowed, but also what is desirable and morally obligated. As Matthews and Caldeira (2008) point out, in order to stabilise the climate what is required are near zero emissions.

2.1.2 Thermal Comfort

Thermal comfort is defined by I.S. EN ISO 7730 (2005) as being 'That condition of mind which expresses satisfaction with the thermal environment'. No explanation is given as to what is meant by 'satisfaction' or indeed how such a concept is to be measured. Thermal comfort is a concept about which much has been written and considerable research undertaken and it covers not just the fields of engineering but also physics and physiology (Tamura, 2016). The ANSI/ASHRAE Standard 55-2009 is one of the presently accepted methods for evaluation of thermal comfort but discussion continues as to how to accurately measure as it is both subjective and personal. The ASHRAE model assumes two different situations, namely one for HVAC buildings where the people have no control over the environment and the adaptive model where people have access to and can open a window (Tamura, 2016). However, neither of these cases apply to cathedrals. People can adapt the clothing they are wearing and can, usually, choose where to sit in a cathedral but they cannot normally either open a window or alter the heating system. However the adaptive model does include other factors not taken into account in Fanger's PMV/PPD (1970) approach (de Dear and Brager, 2002). The PMV or predicted mean vote was Fanger's attempt to calculate when a majority of a substantial group of people felt comfortable and taking into account such things as relative humidity, air speed, the metabolic rate of the people, the air temperature and what clothing they were wearing. The PPD or Predicted percentage of Dissatisfied People, predicts how many people will be dissatisfied with the level of thermal comfort the greater the distance the PPD is from the PMV. It is often considered that thermal discomfort may be seen as a subjective condition whilst thermal sensation, that is how the body feels about changes in the environment, is an objective sensation (Djongyang et al., 2010).

Human bodies constantly produce heat and provided that the amount of heat produced and the amount transferred to the surroundings is in equilibrium, then the human body will feel comfortable.

To remain comfortable however the core body temperature must remain within a very narrow band of $\pm 1^{\circ}\text{C}$ around the resting core body temperature of 37°C (Epstein and Moran, 2006). As the body is constantly producing heat, it is necessary for this heat to be dissipated to the surrounding environment and for the surrounding environment to, in turn, exchange this heat with the body in order to obtain 'body temperature equilibrium'(Epstein and Moran, 2006). Heat is transferred from the human body in a number of ways including convection, where moving air takes heat away from the body because, even in still air, the air itself is cooler than the body and so convection occurs (Bordass and Bemrose, 1996). Other heat transference mechanisms from the human body are by conduction, usually through the floor; radiation, usually from the head which is normally uncovered in churches and evaporation, which is normally caused, in churches by breathing and singing (Bordass and Bemrose, 1996).

Figure 2.1 shows the American Society of Heating, Refrigeration and Air Conditioning Engineers (ASHRAE) graph showing the area of thermal comfort depending on indoor and outdoor temperatures. This is a recommendation and not a regulation in America, and the graph may not be entirely appropriate in other climates.

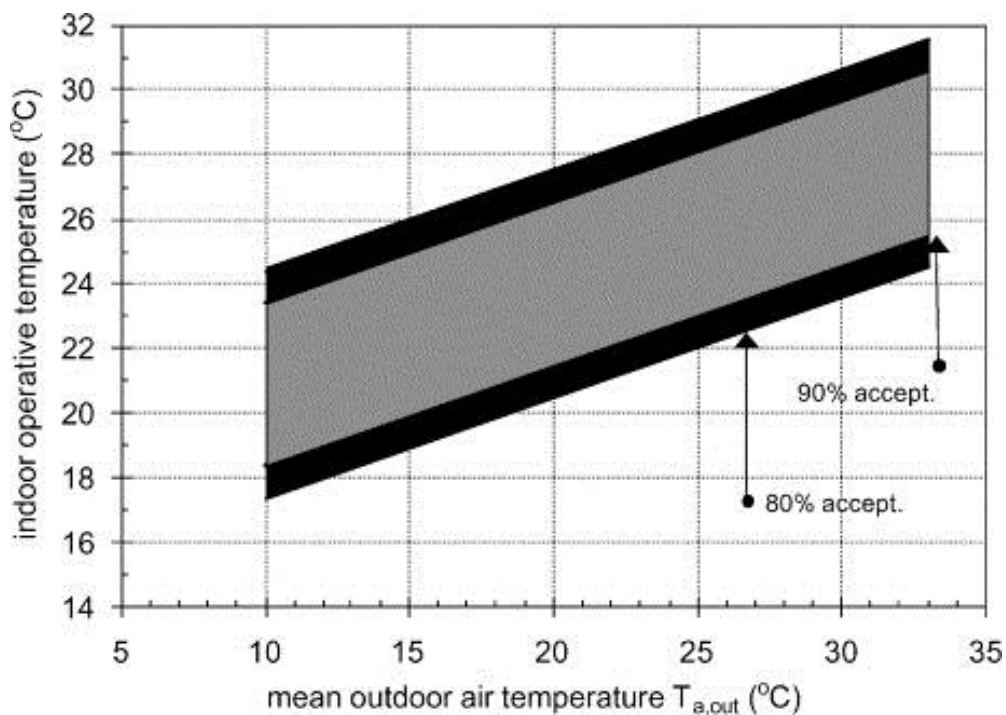

Figure 2.1 - ASHRAE comfort graph illustrating recommended indoor comfort temperatures for external temperature conditions (ASHRAE, 2004)(Byrne, 2014)

As I.S EN ISO 7730:2005 states, 'Thermal comfort is obtained when the internal heat production of the body is equal to the loss of heat to the environment'. Hensen (1991) defines thermal comfort as being 'a state in which there are no driving impulses to correct the environment by the behaviour'. ASHRAE defines thermal comfort as being 'that condition of mind that expresses satisfaction with the thermal environment' (ASHRAE, 2004). ASHRAE states that the zone of thermal comfort, as they call

it and which is shown in Figure 2.1, is where 80% of sedentary people find their thermal environment comfortable (Epstein and Moran, 2006).

Irish Standard I.S. EN 15759-1:2012 clearly states that the requirements for thermal comfort may conflict with the preservation of the building and the conservation of its contents. The standard says however that when this happens, conservations needs, will take priority.

Martinez-Milina (2016) in a survey of the literature available regarding thermal comfort and religious buildings noted the published research given in Table 2.1. The research was published between 1994 and 2005, in relation to thermal comfort and religious buildings. Some countries are much better represented than others which is probably as a result of various academic institutions, in these particular countries, taking an interest in this area.

Table 2.1 - Recent research papers in relation to religious buildings and thermal comfort

Year of Publication	Researcher(s)	Origin of researcher(s)	Location of building(s)	Year of construction	Analysis techniques
2014	Martins and Carlos	Portugal	Portugal	1653	Monitoring
2014	Woroniak and Piotrowska-Woroniak	Poland	Poland	1890–1902	Energy refurbishment
2014	Martínez-Garrido et al.	Spain	Spain	1200	Monitoring
2014	D'Agostino and Congedo	Italy	Italy	1114	CFD
2014	Varas-Muriel et al.	Spain	Spain	1931	Monitoring
2013	Bernardi et al.	Italy and Spain	Italy	1294	Monitoring
2013	D'Agostino et al.	Italy	Italy	1114	CFD
2013	Maahsen-Milan and Fabbri	Italy	Italy	1600	-
2010	Camuffo et al.	Italy, Finland and Poland	Italy	1350–1450	CFD
2009	Balocco and Grazzini	Italy	Italy	1500	CFD
2008	Balocco and Calzolari	Italy	Italy	1232	Simulation
2007	Samek et al.	Poland and Belgium	Poland	1736	Monitoring
2007	Bencs et al.	Belgium, Hungary and Netherlands	Italy	1400	Monitoring
2006	Loupa e al.	Greece	Cyprus	850–1650	Monitoring

Year of Publication	Researcher(s)	Origin of researcher(s)	Location of building(s)	Year of construction	Analysis techniques
2005	Cataldo et al.	Italy	Italy	1068	Monitoring
2000	Bernardi et al.	Italy and Bulgaria	Bulgaria	1200	Monitoring
1995	Tiwari et al.	India	India	1050	Monitoring

Italy is particularly well represented and the majority of the subject buildings are relatively old. The list is extensive, although noticeably Ireland is missing, and gives an idea of the interest being shown and research being carried out in this area on continental Europe. Many of the papers described in detail the methods employed to monitor the buildings but the general consensus amongst the papers was that refurbishing the buildings by installing insulation, by replacing old doors and fixing leaking windows, as well as upgrading the heating systems can be both commercially and environmentally justified (Martinez-Molona et al., 2016).

2.1.3 Predicted Mean Vote

For over forty years the standard way of calculating thermal comfort was to use Fanger's Predicted Mean Vote model (Fanger, 1970). Fanger, who died in 2006, said that the human body will be in a condition of thermal comfort when a number of conditions are met, namely: (1) the body is in heat balance, (2) mean skin temperature and sweat rate, which will influence the heat balance, are within certain defined limits and (3) no local discomfort, such as drafts, exist (Fanger, 1970). Fanger's research was based on laboratory experiments in very controlled circumstances and he was mostly concerned with thermal comfort in office spaces. He wanted heating engineers to be able to predict, given all of the relevant inputs concerning the environment, clothing and activity levels, the largest number of people who would experience thermal comfort. This he called the Predicted Mean Vote or PMV which is an index for measuring the thermal sensations of a controlled group of people using the environmental parameters of air temperature, mean radiant temperature, relative humidity and air speed. He also included two personal parameters relating to clothing and activity (Tamura, 2016).

Using Fanger's own comfort equation he was also able to predict the percentage of dissatisfied people with their own level of thermal comfort. This he called the Predicted Percentage of Dissatisfied people (PPD) (Van Hoof, 2008).

The PPD however only applies to healthy adult people, namely college students in this case (Van Hoof, 2008) and could not be adjusted to take into account of children, the elderly or others. The experiments were conducted under strict laboratory conditions and were not really designed for buildings other than offices. In spite of these limitations the PMV model is still the recognized standard in ISO 7730, ASHRAE Standard 55 (Van Hoof, 2008) although its relevance is being challenged in a number of areas. Arens in particular questions the 'acceptability of three classes of

temperature range currently employed in the ISO and European standards' (Arens et al., 2010). Fanger combined four physical variables namely air temperature, air velocity, mean radiant temperature (MRT) and relative humidity (RH) as well as two personal variables, namely clothing and its insulation properties and activity level which is tied to the metabolic rate (Yau and Chew, 2014). In order to represent PMV, Fanger developed a seven point thermal sensation scale (Table 2.2) (Yau and Chew, 2014) which is also the ASHRAE thermal sensation scale (ASHRAE, 2001).

Table 2.2 - Fanger's Thermal Sensation Scale.

Hot	Warm	Slightly warm	Neutral	Slightly cool	Cool	Cold
+3	+2	+1	0	-1	-2	-3

In a paper entitled '*Environmental warmth and human comfort*', Bedford (1950) set out a descriptor for thermal comfort and when this was integrated into the ASHRAE scale, it produced the following table 2-3. Although the two scales are semantically different, especially in the implication of preference in the Bedford scale, experience has shown that subjects use the two scales in a very similar way.

Table 2.3 - ASHRAE and Bedford thermal comfort scales compared

ASHRAE descriptor	Numerical equivalent	Bedford descriptor
Hot	3	Much too hot
Warm	2	Too hot
Slightly warm	1	Comfortably warm
Neutral	0	Comfortable
Slightly cool	-1	Comfortably cool
Cool	-2	Too cool
Cold	-3	Much too cool

Fanger, whilst being the pioneer in trying to classify and understand thermal comfort, knew that his method was very much laboratory based and that the experiments were carried out in a totally controlled environment. This led to differences between his method and subsequent experiments carried out in the field. It is likely that he was aware of this supposed weakness since he co-authored a paper in 2002, just four years before his death, with the title '*Thermal sensation and comfort with transient metabolic rates*' (Goto et al., 2002) which studied how people perceived their thermal comfort at different metabolic rates. Indeed Oseland (1995) found noticeable differences between thermal sensation votes given in both field and laboratory conditions but this was largely because other researchers were using different groups in different environments whereas he used the same group in different environments. Whilst Oseland was only investigating climate chambers, offices and

homes, he found that ISO7730 overestimated the temperature required for thermal comfort, which has obvious implications for energy use and building design.

The ASHRAE Standard 55 predicted that 90% of people would feel 'thermally satisfied' (Orosa, 2009) with an operative temperature of 22°C in winter and 24.5°C in summer given certain other parameters relating to RH, air movement, metabolic rate and clothing.

In his paper entitled '*Progress in thermal comfort research over the past 20 years*' (de Dear et al., 2013) de Dear found a number of trends: firstly, that there had been a large increase in the amount of research into thermal comfort over the past twenty years, probably because of a general interest in climate change and the large amount of energy consumed by existing buildings stocks. Secondly, that there had been a noticeable move away from the heat balance based model (PMV/PPD) to a complimentary method called the adaptive model which takes into account one's expectations in a particular context and the actuality. Finally, that air movement within buildings was now playing a more prominent role in the research into thermal comfort.

Cathedrals provide a large number of variables, which probably make the PMV/PPD method less relevant than the next method to be discussed, namely the adaptive approach. Whilst people in cathedrals are unable to alter the heating or open the windows they can and do adjust their clothing and can often decide where to sit to maximize heat and avoid drafts. All cathedrals are different, with differing levels of size, heating systems and output, size of windows etc., which will effect air currents. People in general are sedentary whilst in the cathedrals but they are also in the buildings for a relatively short time. All of these factors make modelling the internal environment of a cathedral difficult.

2.1.4 Adaptive Thermal Comfort

With adaptive thermal comfort it has been shown that people will adapt much more readily in order to make themselves comfortable than had at first been thought (Nicol and Humphreys, 2002). The whole principle behind this approach is that if people feel uncomfortable then they will take what steps they can to mitigate against this discomfort (Nicol and Humphreys, 2012). Newsham (1992) was able to show, using FENESTRA modelling software, that people are not static objects within buildings but will move to obtain, what they see, as the optimum thermal comfort. This is probably more possible inside a public building where people are usually free to sit where they wish, rather than in, for instance, an office building where people will have an assigned seating area. Rather than the studies of adaptive thermal comfort being carried out in laboratories as with the NPV approach, adaptive thermal comfort tests were carried out in the field. In addition researchers made a distinction between buildings which were naturally ventilated and those with HVAC systems. Nicol and Humphreys (2002) noted the close connection between thermal comfort and both the climate in

which people find themselves and the buildings which they are using. Leaman and Bordass (1997) talk about the 'forgiveness' of a building and imply that people will look at a certain building and the use to which it is put and will overlook or 'forgive' the building if it does not reach their idea of thermal comfort. There may be a perception for instance that churches and cathedrals will be cold and people dress accordingly and because they expect to be colder than they would like, they are perhaps not so disappointed when this is the case. Baker and Standeven (1996), talk about the 'adaptive opportunity' which is the ability for people to make changes to their environment. These are almost non-existent for the congregation in a cathedral unless one chooses not to sit or to sit near to a radiator or other source of artificial heat. The ability to open windows or to make changes to heating are not possibilities for the congregation but what they can do is it to adapt their clothing and the amount of clothing which they wear. Activity is another way in which people can adapt their thermal comfort levels but this is severely restricted in the setting of a religious service where one is restricted to standing, sitting, speaking and singing. However Nicol and Humphreys (2012) point out that it is a complicated process to try to replicate the physics and physiology of thermal comfort with perhaps as many as 80 examples being produced to date. Auliciems and Szokolay (2007) lists at least 20 major examples but they did not specify cathedrals in their field analysis and concluded amongst other things that both indoor and outdoor factors were important in arriving at a comfort zone of thermal comfort.

The shift from the heat balance or NPV approach to the adaptive approach to thermal comfort is emphasized by the fact that the ASHRAE Standard 55 has been adapted to take into account an adaptive comfort standard (ACS) (de Dear and Brager, 2002). The main principle of the adaptive approach is that the comfort temperature is expressed as a function of the outdoor temperature only (Halawa and van Hoof, 2012). However they do express reservations about this limited approach. Nicol and Humphreys (2002) argue that although only external temperature (rather than any other element) is considered with the NPV approach, namely temperature, humidity and air velocity, they would say that parameters such as clothing and metabolic rate are dependent in any event on the outside temperature. In other words if it is cold outside people will put on more clothing which they will then wear inside and may or may not take off some clothing depending on the circumstances.

Dili et al. (2010) carried out some research in India comparing the perceived comfort levels in houses between naturally ventilated (NV) buildings and those with HVAC. They found that people in the HVAC buildings were much less tolerant of changes to the indoor environment than those in the NV buildings. In other words people in HVAC buildings expected the system to deliver comfort levels within certain limited boundaries whilst those in NV buildings were more tolerant of a wider range of thermal comfort parameters. This in turn emphasises the importance of including the environment

and the building's systems when considering thermal comfort. However, the adaptive hypothesis only includes the outdoor temperature.

Interestingly de Dear in 2011 revisited an old idea called 'alliesthesia' (Tamura and Yoshi, 2016) which raises questions about comfort expectations. For instance, some people may express satisfaction with the thermal comfort inside a cathedral even though it is quite cold inside because they were expecting it to be even colder, or put another way, 'one man's breeze is another man's draft' (de Dear, 2011).

2.2 Thermal Considerations in Heritage Buildings

2.2.1 Thermal Mass

Thermal mass describes the materials found in a building which have the ability to store and then release thermal energy (Walsh et al., 2006). Their ability to do this smooths out large fluctuations in temperature when artificial heating is not being applied. In the case of a church, which usually has a large area of solid stone walls which are good for their thermal mass performance, this would mean that when the building is not occupied, such as at night, the walls slowly release the heat they accumulated during the day. This suggests that less heat must be generated from artificial sources during the day. Thermal mass means heat retention and release which suggests that in a massive building, such as a church or cathedral, the peak temperature reached will be lower and later than if the building had no thermal mass capabilities. Figure 2.2 shows the effect of this delay and reduction in temperature maximisation and demonstrates how useful that may be, particularly in buildings which are largely used during the day when artificial heat need not be present during the night.

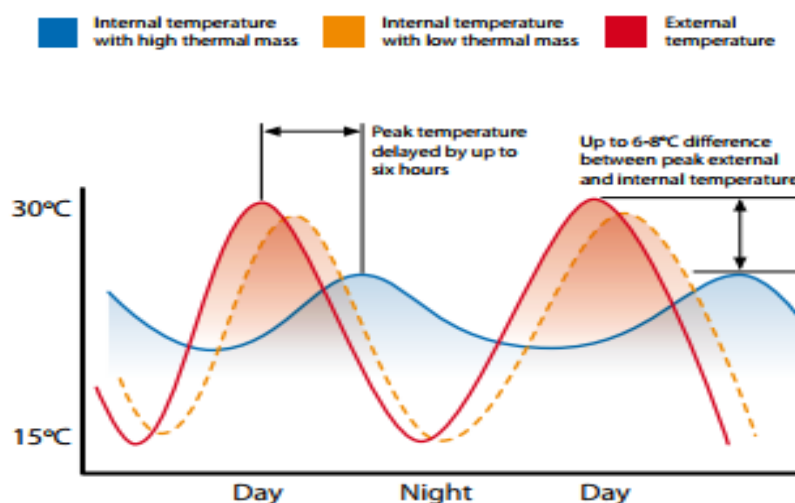

Figure 2.2 - Stabilising effect of thermal mass on internal temperature (De Saulles, 2005).

Furthermore as Arnold (2013) states, buildings with large areas of windows, can benefit from passive solar gain which increases the building's thermal capacity. This can be demonstrated by the earth which has the capacity to store and release enormous amounts of thermal energy. Without thermal

mass the maximum temperature would be reached at midday when the sun is at its highest point but, in fact, because of the effect of thermal mass, the maximum temperature is reached at around 2pm (Walsh et al. 2006).

There are three basic properties which are needed to provide reasonable levels of thermal mass (De Saulles, 2005):

1. A high specific heat capacity.
2. A high density. The higher the density the greater the amount of heat which the material can store.
3. Moderate thermal conductivity so that heat flows to and from the building are approximately equal to the daily heating cycle.

Thermal conductivity (K) is a measure of the rate at which heat is conducted through a particular material under specific conditions and is expressed in units of W/m K. In modern buildings it is possible, using insulating materials, to decrease the speed at which heats travels through walls and roofs and this is called decrement delay. Since, for instance, dry lining the inside of cathedral walls is usually not an option for heritage reasons this artificial adjustment to thermal mass is not relevant for such historic buildings and thermal mass will remain at whatever rate is provided by the natural materials (de Saulles, 2009). Attempts have been made to adjust thermal loads in modern buildings using thermal mass but, as Braun (2003) points out, the number of variables is large which may reduce the effectiveness. Balaras (1995) identified all of these variables and compared the various design methods and tools in order to arrive at a method of calculating the cooling load and indoor air temperature of a building.

Karlsson et al., (2013) considered a conceptual model to establish if it was possible to enhance the thermal mass of heavyweight buildings by adding materials to them which had particularly good thermal properties. He was examining mostly large modern buildings and modern materials such as concrete but also investigated the cost savings that may be possible with such additional materials. The general consensus was that 'what one gains by not heating in one period is approximately lost when one has to heat more before people enter the building.' (Karlsson et al. 2013). This seems to be corroborated by Bloomfield and Fisk (1997) who concluded that ' the additional thermal inertia of heavy-weight buildings do not offer any substantial energy savings in the case of daily intermittent heating', although, they agreed that the intermittent heating strategies need to be compared with the internal thermal inertia of the building in order to be optimised. Zeng et al. (2011) have done some work to try to show that by working out the specific heat of the building envelope, the ideal level of thermal mass can be established. This research is more often applied to modern buildings and research does not yet appear to have been carried out on much older buildings. Active thermal mass enhancement has been researched for some time but now work is being carried out to

establish if this can be further extended by the use of phase change materials (PCM) (Whiffen et al. 2012). In laboratory conditions they achieved an additional energy storage capacity of 12% and a 29% increase in active surface area depending on the PCM being used. It will be interesting to see if an aesthetically acceptable PCM can be developed which would be suitable for heritage buildings. This is likely to be some kind of clear coating which can be applied to existing solid walls without affecting their permeability or appearance.

In a recent paper Reilly and Kinnane (2016) have challenged the notion that thermal mass is always a good thing and they suggest that existing studies have ignored the interaction between intermittent use of the properties and heating and thermal mass. They suggest that, in certain circumstances, thermal mass may be unhelpful as it may, given certain parameters, actually increase energy consumption rather than reduce it for the reason that a high thermal mass, intermittently used, building will require more energy to heat it up than a low thermal mass building.

2.2.2 Heat Transfer

The First Law of Thermodynamics or the Law of Conservation of Energy states that matter cannot be created or destroyed, it is simply changed or transported from one place to another. It follows then that heat transfer is the movement or conversion of a source of energy. It is defined by Incropera and DeWitt (1996) as 'heat is energy in transit due to a temperature difference'. Heat can be transferred in a number of ways namely, convection, conduction, and radiation (Bordass and Bemrose, 1996). Whenever two bodies with different temperatures come together there will be a movement from the warm to the cold, that is, heat transfer occurs between the two. In the case of cathedrals if the interior of the building is warmer than the exterior, which it normally is, then the warm air will attempt to move to the outside usually by conduction through the fabric. This movement of heat through the building envelope can take place through the floor, walls, roof, windows or any other part of the envelope.

Convection is the first method to be examined and it is an important element when considering thermal comfort (Bordass and Bemrose, 1996). This is because the air is usually cooler than the body and so heat is transferred from the body to the air surrounding it and this will make the body cool down. The body is constantly producing heat from the food which it consumes. The average body when sedentary produces about 70 Watts of heat per hour (Bordass and Bemrose, 1996). What distinguishes this method of heat transfer is that it involves the movement of fluids or gases but never solids. What is relevant in cathedrals is air. When it is heated it expands and, because this makes it less dense than the surrounding gas, it rises with the cooler air coming in below it. In cathedrals this can lead to stratification with layers of different temperatures of gas at different heights. This type of convection is sometimes called free or natural convection, as opposed to forced

convection such as when a fan is used to force a body of air across an element (Incropera and DeWitt, 1996).

Conduction is another method of heat transfer and is the ‘transfer of heat energy through a material without the molecules of the material changing their basic positions’. It can also be considered as the movement of energy from a more active or energetic collection of particles to a less active or less energetic collection of particles (Incropera and DeWitt, 1996). The formula for calculating the thermal conductivity of a material through a body is as follows: (McMullan, 2007).

$$\frac{H}{t} = \frac{\lambda A(\theta_1 - \theta_2)}{d} \quad \text{Eq. 2.1}$$

where:

λ = coefficient of thermal conductivity for that material (W/m K)

H/t = rate of heat flow between the faces (J/s = W)

A = cross-sectional area of the sample (m²)

$\theta_1 - \theta_2$ = temperature difference between the faces (°C or K)

d = distance between the faces (m)

Radiation is emitted from all bodies with a temperature greater than absolute zero (0°K). McMullan (2012) describes it as ‘the transfer of heat energy by electromagnetic waves’ and the rate at which a body emits or absorbs radiant heat is dependent upon the nature and temperature of its surface. Bordass and Bemrose (1996) state that, the amount of radiation from a surface, is directly proportional to the size of the surface. The largest local example of radiated heat is of course from the sun to the earth (Byrne, 2013). Unlike conduction and convection which require a medium for the energy to move through, such as a solid or a gas, radiation does not, as radiation is transported by electromagnetic waves. For example, as radiant heaters do not directly heat buildings, they only need to be turned on shortly before the building is to be used, to heat up, in the case of churches and cathedrals, the pews, floors and indeed the people themselves. Most radiant heaters in cathedrals are electric and electricity is an expensive fuel meaning that this type of heating is not suitable for long term use. The output from radiant heaters can be measured by their emissivity which is the amount of energy emitted from a surface compared with the amount which would be emitted from a black body, which is considered to be a perfect emitter, at the same temperature and wavelength.

2.2.3 Building Heat Loss

A building can lose heat in a number of ways (figure 2.3) but usually through the building envelope. Likely rates of heat loss from a typical domestic building are shown in Figure 2.4 (Holmes-insulation,

2012). These figures however depend on many variables such as location, size, efficiency, usage, temperature difference externally and internally and the type and level of insulation, if any. As McMullan (2012) states ‘the heat loss from a building decreases as the insulation of the external fabric of the building is increased’. The location of a building can also have an effect on the rate of heat loss. A prominent building situated on a hill will be subjected to wind which, when it blows across the surface of the building, can increase the rate of heat loss. A building in a city center which is surrounded and protected from the wind by other buildings may not be affected to the same extent. The usage of the building may also have an impact on the rate of heat loss. A building which is in constant use and with doors which are regularly being opened to the outside gives rise to ventilation heat loss when hot air escapes to the outside and is replaced with cooler air and this will inevitably lead to an increased rate of heat loss (Byrne, 2013).

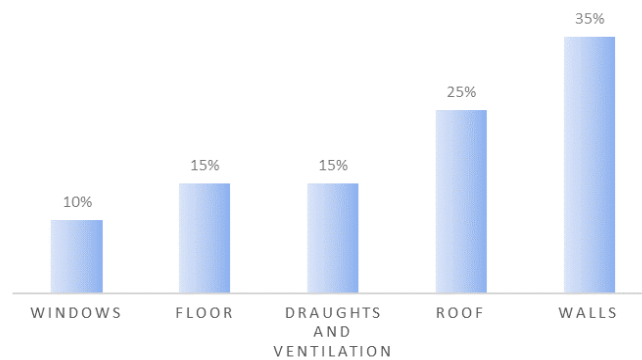

Figure 2.3 - Likely rates of heat loss from a typical domestic building (Byrne, 2013)

It is possible to estimate the rate at which heat is lost from a building. The problem is that the calculations assume what is called ‘steady state conditions’ which means that the temperatures inside and outside the building are assumed not to change over time. Obviously they do, with the diurnal and nocturnal changes as well as larger seasonal changes. However, assuming that steady state conditions do exist, then the heat loss is categorised as either being fabric loss or ventilation loss (Byrne, 2013).

The rate of heat loss through a particular element or building material can be calculated. It is called the materials U-value and is measured in Watts per square meter per degree Kelvin temperature difference between the inside and outside (Bordass and Bemrose, 1996). The smaller the U value the better the insulation or in other words the smaller the U value the longer it takes for heat to pass through the material. For new buildings the acceptable U values are often set down in the relevant building regulations and for existing buildings these are laid down by the European Union.

As heat loss is considered to be a form of power it is measured in Watts. Ventilation heat loss is when warm air escapes from the building through exfiltration and is replaced with cooler air. This inward movement of cool air is called infiltration.

One problem is that buildings such as churches and cathedrals, seldom display steady state conditions and especially as the majority use intermittent heating. In this case it is necessary to consider the thermal admittance which is a measure of the ability of a material to exchange heat when subject to variations in temperature. The larger the admittance the smaller will be the temperature swing inside the building.

Being situated in Ireland heat gains are not an obvious issue but with such large south facing roofs and with ever increasing summer temperatures in Ireland this may become an issue in the future.

The K or thermal conductivity value is the value of individual layers which may make up, for instance, a wall and it is the rate at which heat is conducted through the material under particular circumstances.

The U value is closely related to the K value which is the rate of resistance of each component of an element to heat transfer. The U value is the combination of all of the K values and expressed as $U = \frac{1}{Rt}$.

Stone built walls, even if faced with ashlar, will always have a rubble infill and it is necessary to know the R value of each individual component of the rubble to calculate the U value of the wall.

In Table 2.4 below (Bordass and Bemrose, 1996) indicates the U values for elements often found in cathedrals. However they do not specify the type of roof referred to, the thickness of the element or how the calculations were made. Also they do not specify the type of flooring referenced. However the U values may be of guidance in certain circumstances and so are quoted here.

Table 2.4 - Cathedral's building components and its U values

Cathedral's components	U (W/m ² K)
335mm solid block wall with dense plaster	1.7
Thick stone wall, with lime plaster	circa 0.8
Uninsulated roof	circa 2.0
Single glazed window	circa 5.5
Stone floor, 30 x 10 metres, uninsulated	0.45
Stone floor, 60 X 20 metres, uninsulated	0.25

2.3 Heating Types

The lack of published material about the utilities in Irish cathedrals is exemplified by Day and Patton (1932) in their otherwise excellent book on the cathedrals of the Church of Ireland, where no reference whatsoever is made about the heating in any cathedral, cathedrals which they describe otherwise in great detail. The work of Galloway (1992) has been quite extensively used in this research but, although it describes the cathedrals of both traditions, as well as the ones no longer in

use, it is largely a summary, albeit a useful one, of other's work but again throughout the book no mention is made of utilities. It is likely that the political and religious instability in Ireland over many centuries has led to a lack of interest in the detailed recording of the architecture of Irish cathedrals and that certainly is the case in the Church of Ireland which was for a long time associated with the, not-too-popular English (Milne, 2000).

Kinsella (2009), whose work concerns the architecture of Christ Church cathedral in Dublin, makes very little mention of the heating in the cathedral although he does include a photograph, taken before the Street restoration of 1871 to 1878, which appears to show a stand-alone stove in the nave. Christ Church cathedral possesses a well-documented example of a large restoration and yet even here little mention is made of heating in the many surviving documents. In the reports written by the then prospective architect Edmund Street to the Dean and Chapter in 1868 (and again in 1871), no reference could be found of heating although there is reference to the proposed design for one of the lights. The north side of the cathedral today shows evidence of a number of chimneys and yet no reference to the heating appears to be in existence. Kinsella (2009) points out that the cathedral would almost certainly have had, after the stand-alone stoves had been replaced, a hypocaust hot air system which was common in English cathedrals at the end of the 18th century. This type of heating was a Roman invention whereby hot air was blown along channels under a floor. Many examples of these early systems can be seen still in Roman excavations in places such as York and Bath. The hot air would have been channeled along pipes in trenches rather than providing underfloor heating as it is known now. It is likely that when these systems were being introduced at the end of the 18th century the possibility that heating systems could cause problems to the fabric and interior of the cathedral would not have been known and the provision of some form of heating and lighting would have been presumed without enquiring too much as to their affects. In her short work on St. Fin Barre's cathedral in Cork, Healy (2006) makes reference to an underfloor heating system which had begun to fail and was to be replaced during the major restoration work which was carried out in the cathedral in 2000. Fortunately the new system is well documented and the information should be of value to future researchers. In particular, Burgess (2003) gives a full description of the new heating system.

In a paper entitled *'The warming and ventilation of Victorian and Edwardian churches'* by the Heritage Group of CIBSE, produced in 1999, Roberts and Ferris (2006) give a short history of church heating during that period and the engineers who developed the systems. They point out that steam heating was introduced by William Cook in 1745 but was refined by the famous steam engineer James Watt in 1784 and they say that it is possible that the first church heated with this system was in Dublin in 1796, although they do not give the name or location of the church. As Roberts points out, most churches (and cathedrals) at this time were only heated either with hot air or hot water

where hot water seems to have been the preferred medium; with many thousands of churches in the UK being heated with various hot water systems. Although evidence is very scarce about Irish churches and cathedrals it would have been unlikely that they did not follow the example of the UK. A number of engineering papers and books appeared at this time, such as '*A treatise on the economy of fuel and management of heat*' by Robertson Buchanan in Glasgow in 1815 and '*The principles of warming and ventilating Public Buildings, etc.,*' by Thomas Tredgold in London in 1824. Tredgold in particular acknowledged the difficulty of heating churches. Undoubtedly all of these systems were an improvement over the early stoves and open fires which often had no flues, but these systems did encourage research into systems, after which the boiler became separated from the area in which the heat was required.

Nowadays all cathedrals are already fitted with some form of heating but where a system is being replaced or augmented the European Union lays down guidelines which must be followed and items which must be considered before any new system is put into place. The European Committee for Standardisation (CEN), approved European Standard EN 15759-1 (2011) on 8th October 2011 and this relates to the guidelines for heating churches, chapels and other places of worship (IS EN 15759 – 1). This document, compliance with which is obligatory for members of CEN, as Ireland is, states that, in the event of a new heating system being contemplated for a place of worship the following guidelines will be complied with in order to arrive at the best decision:

- I. assess the building, its interiors and contents;
- II. determine an indoor climate specification with respect to conservation and thermal comfort;
- III. determine an appropriate heating strategy;
- IV. select and design an appropriate heating system;
- V. implement the proposed changes;
- VI. evaluate the effectiveness of the heating system with respect to the specification.

It is unusual for a cathedral to have the financial resources to replace the entire heating system which they have and what is more usual is that boilers are replaced or perhaps fuel changed from oil to gas. This thesis may give useful advice on this matter based on the research contained therein.

Heating cathedrals can be divided into those systems which heat the whole volume of air within the buildings and those systems which principally heat the people in the building. Heating systems in cathedrals need to fulfil three main obligations, namely to provide an adequate level of thermal comfort for those using the building, to conserve the fabric of the building and to preserve the

artefacts contained within the building (Makrodimitri et al., 2012). A compromise between these three factors is usually necessary.

The most common form of heating found in Irish cathedrals is central heating which is where the heat source or boiler is situated in one place, sometimes not within the building being heated, and heat is then distributed around the building using water with pipes and radiators. This is known as a low pressure hot water (LPHW) system. When originally installed many systems moved the water using gravity but modern systems use pumps (Bordass and Bemrose, 1996). These systems were quite intrusive and damaging to the fabric of many cathedrals when installed due to the necessity of drilling holes in the walls for the pipe runs. Space also had to be found for the boiler and often, especially if oil fired, for a tank.

Underfloor heating where hot water is pumped around under the floor, is a common heating method in heritage buildings. Underfloor heating is particularly efficient when left on constantly at low levels of heating but is not so suitable for intermittent heating. Underfloor heating can be very expensive to run and often impossible to install without intrusion when buildings have historic tiled or ornate floors (Bordass and Bemrose, 1996). They are usually only retrofitted at a time of major restoration.

Heat emitters are another form of heating, usually in the form of radiant heaters of various types and sizes. Panel heat emitters are not always suitable in heritage buildings as they can be dangerous to young and old people who may come in contact with them. A recent paper by Lodi et al. (2017) has shown that heat emitters may be relevant for areas such as offices due to their cost savings and effectiveness at delivery of local heat. Thermal radiation 'is energy emitted by matter that is at a finite temperature' (Incropera and DeWitt, 1996). These heaters primarily heat the people in a building rather than the building itself. They have major advantages for intermittently used buildings in that they cause less disruption to the internal thermal environment. However they do not always provide adequate levels of thermal comfort, especially for those not in the direct line of the electromagnetic waves which the electric heaters emit. As Bordass and Bemrose (1996) point out, they are expensive to run and are not generally aesthetically pleasing. Samek et al. (2007) confirmed these observations and concluded that such heaters do provide local heating without adversely affecting the building or its contents. They do point out the importance of not allowing art work and items of value to be too close to or in line with the radiation from such heaters. They also considered the issue of suspended particle matter (SPM) which can be a problem for art work. They concluded that radiant electric heaters do not create convectional currents and that as a result these heaters do not cause concentrations of SPM indoors (Samek et al., 2007).

In 2009 the European Union funded a 'Friendly Heating' project (Camuffo et al., 2010) to find a heating system which was 'comfortable to people and compatible with conservation of art works preserved in churches.' They were concerned with the disturbance to the internal microclimate of

these buildings caused by artificial heating. The conclusion was that low temperature radiant heaters, mounted in the pews, provided an adequate level of thermal comfort without adversely affecting the building or its contents. Figure 2.4 shows the suggested solution which provides an adequate amount of heat to the seated person without heating up the building in which they were sitting. By placing electric heating elements in locations A, B and C, Camuffo and his team were able to show that an acceptable level of local thermal comfort could be provided without the time and expense needed to heat up the whole building. They acknowledged that electricity was an expensive power source but pointed out that it is only required for a short duration, that is the length of a service rather than the hours which are often necessary to pre-heat a whole building.

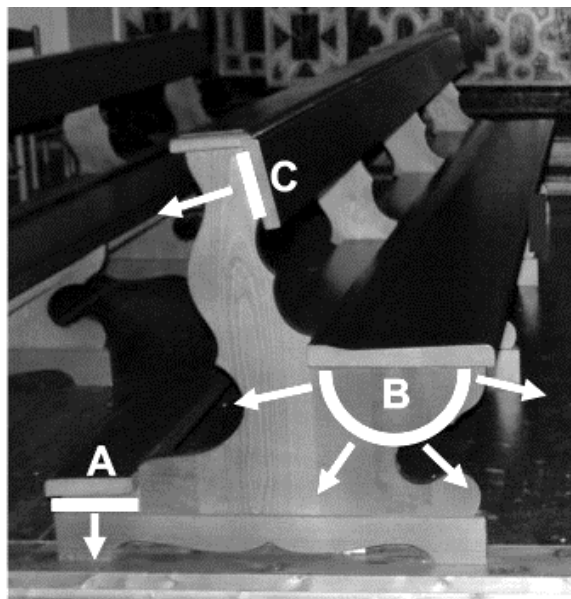

Figure 2.4 - Three IR emitters located on a pew in a church. A. Under a kneeler. B. Under a seat. C. On the back of the front pew toward hands (Camuffo et al., 2010)

There are other forms of pew heating and in cathedrals such as Killala in the west of Ireland it is possible to observe under pew hot water pipes heated by a small gas boiler. There is a danger with these systems that they may cause damage to the pews themselves as the wood expands and contracts (Bordass and Bemrose, 1996).

Hot air systems are not common in Ireland but have the advantage of a fast heating up and cooling down time and hence it is the people in a building rather than the building itself which are heated by these systems. Cork (RC) cathedral and Enniskillen (CI) cathedral are examples of this type of heating being used in Irish cathedrals. These systems are what are known as forced-air systems (Bordass and Bemrose, 1996) which have the advantage of creating a positive air pressure within the building which can help reduce the ingress of cold air and dirt from outside (Fielden, 2003). Camuffo (2010) shows, however, that these systems can cause considerable air turbulence and an increased risk of deposits of SPM on art work. He points out that candle smoke can be a particular problem with this type of heating where candles are in use. Bencs et al., (2007) confirm this view as they say that these

systems increase 'the supply, transport and deposition probability of air pollutants'. Stratification is known to be a problem with hot air blower heating systems (Camuffo, 2010).

A number of researchers point out that, in relation to many heritage buildings and especially intermittently used ones, there will always be a compromise between thermal comfort, conservation and preservation. In relation to churches in particular Mills (1959) states that 'church heating systems should be designed for economical running, the minimum of labour in servicing and maintenance, unobtrusive appearance and efficiency as a heating medium'. Add conservation and preservation into those requirements and it is unlikely that any heating system could address all of these issues fully. Aste et al. (2016) stated that it is a challenging task because so many different variables have to be satisfied simultaneously. Their conclusions, based on their examination of a church in Italy, was that local heating was preferable to heating the whole building, at least from a conservation and preservation standpoint. They did admit that more work needed to be done to establish if these local systems were capable of providing a reasonable level of thermal comfort whilst at the same time protecting the building and its contents.

2.4 Moisture

The amount of water vapour in the air at any one time is variable and can be quantified in a variety of ways. Stull (2000) notes the following measures: 'vapour pressure, mixing ratio, specific humidity, absolute humidity, relative humidity, dew point depression, saturation level, or wet bulb temperature'. The two areas of most interest in heritage buildings are the absolute humidity which is the amount of moisture in the air (in g/m^3) and relative humidity, which is the amount of water vapour in the air compared with the maximum amount of water vapour the air could hold, at a particular temperature. Camuffo (2014) makes the point that air is actually made up of a number of gases and vapours and Dalton's Law which states, broadly, that when gases are mixed each gas must be treated separately since each gas is independent of the other gases. Camuffo (2014) claims that 'air' is not an individual gas, but a collection of gases. It is the element of temperature (T) which makes relative humidity (RH) so important since, generally, as T rises RH falls and vice versa. Why this is so, is evident from the definition of RH above, namely that the higher the T the greater the amount of moisture which can be held in the air.

This is important in a heritage building because T might be set at a level which provides for a good level of thermal comfort but which may result in a low RH figure if the air is notably dry which could damage the building and its contents. For instance timber, which is hygroscopic, swells when wet and shrinks when dry and many heritage buildings contain large amounts of timber. The same principle applies to books and paintings which is why it is important to arrive at a compromise between T and RH which, as closely as possible, partly fulfils the requirements of thermal comfort, conservation and preservation. Bordass and Bemrose (1996) stated that 'the relationship between temperature and

relative humidity is crucial to the influence of heating on the fabric and contents of churches.' It is known that high RH figures can lead to mould growth, condensation and various other processes which are damaging to the material involved (Feilden, 2003).

In the UK the National Trust owns and manages thousands of important buildings, many of which contain valuable collections and artefacts. These buildings usually contain many items which are of historic interest but which are also very susceptible to sharp changes in T and RH. As a result they have adopted a system of conservation heating whereby the RH figure is set and the T adjusts accordingly. Usually in cathedrals it is T which is set, for instance, by a thermostat, and the RH adjusts accordingly. The National Trust sets RH figures of between 40-65% for its collections (Bullock and Blades, 2013). It is generally accepted that in cases where conservation heating is employed in relation to heritage collections, 'control of relative humidity is more important than control of temperature' (Michalski, 1998). However, Neuhaus and Schellen (2007) acknowledge that during the heating season, conservation levels of heat will not provide adequate levels of thermal comfort.

IS EN 15759-1:2011 states that in relation to thermal comfort, RH must be kept in the range of 30-80% but with regard to T, the standard specifies that 'there are no standards that apply specifically to comfort in places of worship' and also that in relation to conservation 'the general standards on thermal comfort are not automatically applicable to places of worship'. The standard points out that each building must be considered on a case by case basis taking into account air movements, radiant temperature, the activity of the people, their clothing as well as their personal preferences.

2.4.1 Moisture ingress into heritage buildings

Moisture can exist in a building in a number of ways. Condensation is a common form of internal moisture and is caused when warm moist air comes into contact with colder air or with a cold surface. This cools the air to its dew point and at that point it is saturated and can no longer contain the moisture suspended within it and the excess water vapour condenses into a liquid. Condensation in buildings is of two types, surface and interstitial condensation.

Surface condensation has been described above and interstitial condensation is similar but occurs when condensation forms within a building fabric such as inside a wall. Moisture can enter the wall by a variety of means and depending on the construction of the wall, the air in the voids in the wall may be cooled by conductance and reach its dew point at any place within the thickness of the wall as the moist air travels through it. This type of condensation can cause substantial damage and is difficult to detect.

Moisture in stone walls can be measured and two international codes are relevant for doing this, namely ISO 13788:2012 which sets out the rules with regard to dew point assessment and IS EN 15026:2007 which sets out the rules for using numerical simulations (Little et al., 2015). As vapour

pressure increases when the moisture content increases and because more moisture is generally generated inside a building by occupancy and activity, there is a general understanding that since the vapour pressure inside a building is greater than the vapour pressure outside, water vapour travels from the inside to the outside. For this reason interstitial condensation is most likely to occur as moist air moves through the structure from the inside to the outside. In modern buildings this can be prevented by installing various types of vapour barriers, insulation or internal dry lining but this is generally not possible with heritage type buildings.

Moisture can also penetrate into a building as a result of rain hitting the outside of porous masonry walls and travelling through the walls. Older buildings are also much more likely to suffer leaks from roofs and down pipes than modern buildings, further adding to the problem. Often rain water will enter a building at one location but can then travel substantial distances, if it meets an impervious internal barrier, before becoming evident in another part of the building. This type of leak is particularly hard to trace in such large structures as cathedrals and large heritage buildings because of the often complex construction of the roofs and buildings. It is important to note that after rain, infiltration occurs because the outside RH is then higher than the internal RH and this moist air enters through open doors, leaking windows and permeable roofs.

Another method of moisture ingress is by capillary action principally due to rising damp. Most modern buildings rely on damp proof courses to prevent such ingress but heritage buildings often rely solely on the width of the walls and depth of the foundations to stop moisture from rising up from the ground (Little et al., 2015) To give one example of this, some of the walls in St. Peter's Basilica in Rome are 13 m thick (Feilden, 2003). The smaller the size of the capillary the higher will be the rise and capillary rises in old stone walls have been, not uncommonly, as high as ten meters (Feilden, 2003).

Another method of moisture production is from people and their clothes. It is common for people to enter a heritage building and particularly church wearing wet clothes and as they warm up and dry out this moisture evaporates into the internal atmosphere causing changes to the internal environment within the building. People themselves give off moisture through sweating on warm days and through breathing, where the latter can give rise to around 50 grams of water vapour per hour (Bordass and Bemrose 1996). If, for instance, 800 or so people attend a service in a cathedral then they generate, even in their sedentary state, a large volume of moisture and a significant rise in relative humidity in the air can be observed under a constant temperature.

2.4.2 The Psychrometric Chart

The psychrometric chart was developed for ASHRAE and whilst mostly used in the design of heating ventilation and air conditioning (HVAC) systems, it is a useful tool in displaying the variables used to

specify humidity. Although not used in the research on this project it is included here to show the interaction between, temperature, humidity, absolute humidity and the dew point.

Error! Reference source not found. shows the type of application to which the chart can be used in, for instance, determining the area of greatest thermal comfort and taking into account the various moisture and thermal variables (Sustainability workshop, 2017).

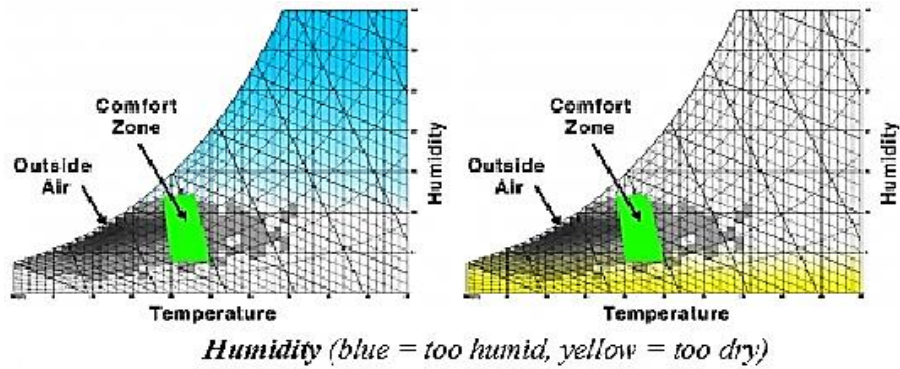

Figure 2.5 - Psychrometric chart being used to show the relationship between T and RH and used to calculate the comfort zone of a building or area (Sustainability workshop, 2017)

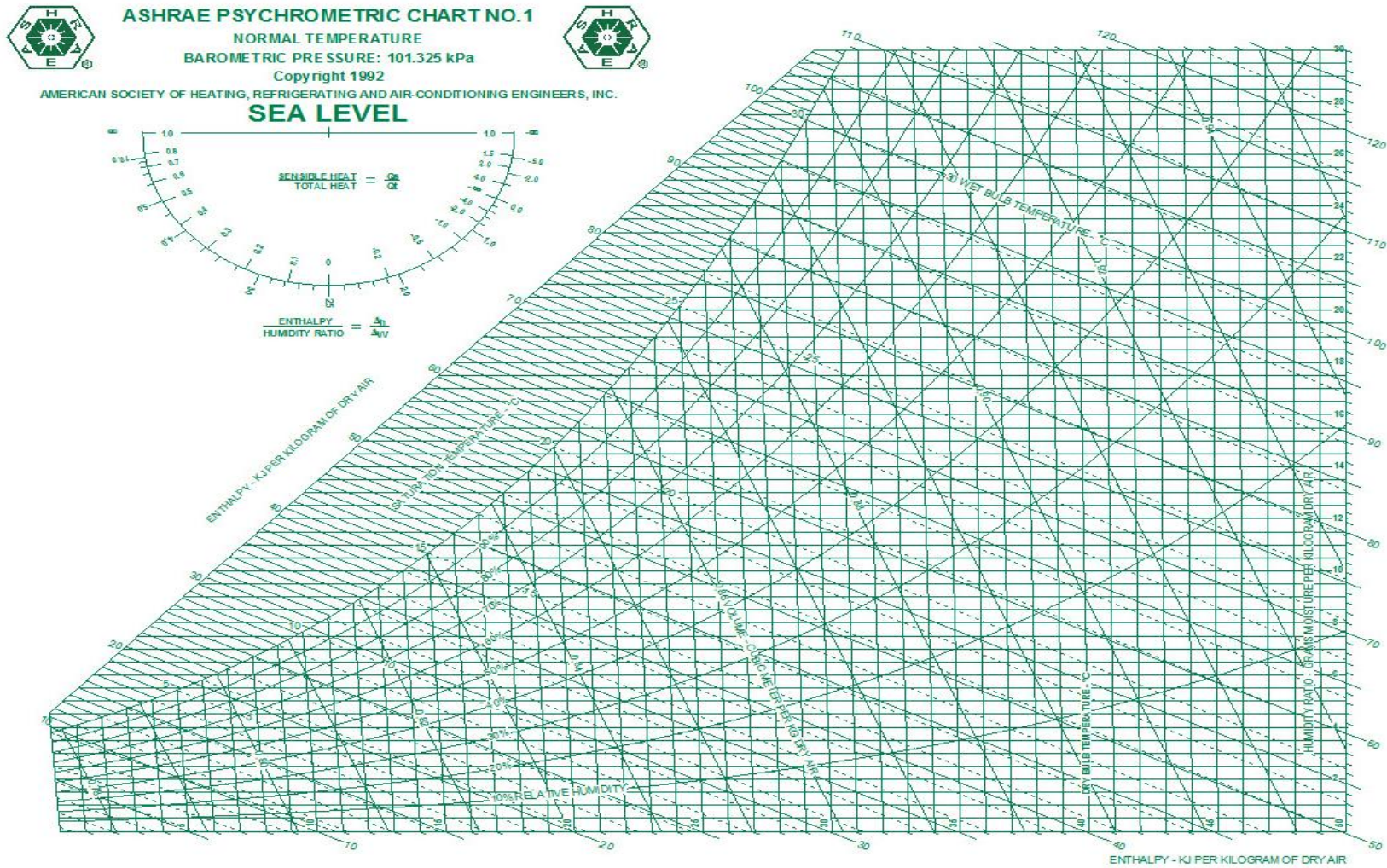

Figure 2.6 - ASHRAE Psychrometric Chart at sea level (ASHRAE, 2009)

2.5 The Effects of T and RH on Buildings and their Contents

Buildings can suffer decay from a large number of sources such as wind, moisture penetration due to rain, solar radiation, frost and snow, dissolved salts, deposit of particulates, botanical, biological, and rot (wet and dry), according to Feilden (2003).

Each of the above elements will depend on many variables such as the location of the building, its orientation, its age and the composition of the materials used to construct it. *Wind* is the result of air movements between high and low pressure areas and as well as the obvious mechanical stresses caused to a building on the windward side there are also stresses caused by turbulence and low pressures on the leeward side. Wind born particles, such as sulphates and salts, can also erode the outside envelope of a building. Rain and moisture penetration can cause movement of moisture and salts through the structure causing *efflorescence* on the inside and/or outside as shown in Figure 2.7 which is a photograph from a cathedral in Ireland.



Figure 2.7 - Efflorescence on an East facing, outside wall of an Irish cathedral

The damage caused by dissolved salts will depend to some extent on the type of salt being dissolved. However when the internal temperature is higher than the external temperature and warm moist air travels through a wall or other structure it draws salts with it. These salts dissolve inside the walls but may crystallise on the outside which, over time, weakens the wall as the salts are removed from it and from the mortar holding it together. In the case of heritage buildings which are near to the sea, they may also be more susceptible to salt water erosion and damage than others which are further from the sea (Camuffo, 2014). Arnold and Zehnder (1990) had noted that when salt crystallises in the pores of stone it expands which exacerbates the problem. Arnold and Zehnder (1990) noted that when salt crystallises in the pores of stones that they expanded which exacerbates the problem.

Solar radiation can cause the expansion and contraction of structural components with the albedo effect being used to determine the amount of solar radiation which is reflected from a surface (Feilden, 2003). *Frost and snow* can have a similar thermal effect or through water entering cracks in the outside walls, freezing and expanding causing further damage.

Botanical degradation is caused when plants gain a foothold, developing intrusive roots in, for instance, a masonry wall and causing damage to the wall. *Biological deterioration* is normally internal and caused by such things as wood worm which, by drilling holes in wooden fittings which weakens the structure.

Dry and wet rot are major causes of decay in heritage and indeed other types of buildings. Dry rot is a fungus and its rhizomorphs can travel long distances from the main body of the fungus to find new sources of food which is primarily the cellulose in wood. By eating away at the wood the fungus weakens the structure (Feilden, 2003). The fungus can be controlled by keeping RH below 20% but in Ireland this normally requires a very high T which would not be acceptable from a thermal comfort view point. In the case of churches and cathedrals for instance, the Institute of British Organ Building (IBO) states that an RH reading of below 50% is potentially damaging to pipe organs (IBO, 2003). The main problem with dry rot is that it carries its moisture with it unlike wet rot which does not. Wet rot requires a moisture content of 25% (Feilden, 2003) before it will feed on timber and because it does not carry its required level of moisture within it, its effects are more localised than with dry rot, which can travel up to 20m from its source (Feilden, 2003). Both dry and wet rot are dependent upon and affected by various levels of moisture and heat.

There can also be *ground movements* and *load shifts* over time which can cause deformations. For instance, in the 1960s it was discovered that parts of York Minster cathedral in England were in danger of collapse as a result of settlement over time. In the case of the central tower each of the pillars was estimated to be holding a weight in excess of 4,000 tons. The conservation and restoration work required many years and millions of pounds to rectify.

Condensation both interstitial, where it forms inside the structure for instance inside the walls and surface condensation, can be a major causes of decay. It is an important consideration when deciding on the type of heating system to be employed and the fuel to be used.

Bordass and Bemrose (1996) list the following self-explanatory possible adverse effects of heating on a building including fire, fumes, staining, thermal contortion, condensation and dampness, drying out, leading to shrinkage and cracking, moisture transfer, and damage to roof structures.

2.5.1 The effects of moisture on the contents of historic buildings

High humidity levels can degrade internal fittings and fixtures in a number of ways and these have been set out by Thompson (1994) especially in relation to damage caused by light, humidity and air pollution. He points out that, with regard to museum collections, changes in temperature are not nearly as important as changes in relative humidity. Beck and Koller (1980) emphasize that internal temperatures during the heating season should not exceed 11°C and Briggs (1980) goes even further by saying that the temperature should not exceed 10°C for museum collections. Neither of these

figures, whilst they might protect the contents of a cathedral, museum or other heritage building, would provide anywhere near an adequate level of thermal comfort, which once again emphasizes the potential conflict between thermal comfort, conservation and preservation.

Figure 2.8 shows the environmental considerations which should be taken into account when considering the care and maintenance of cultural collections, as produced by the British Standards Institution (BSI, 2012). This shows clearly the importance of both temperature and relative humidity for such items.

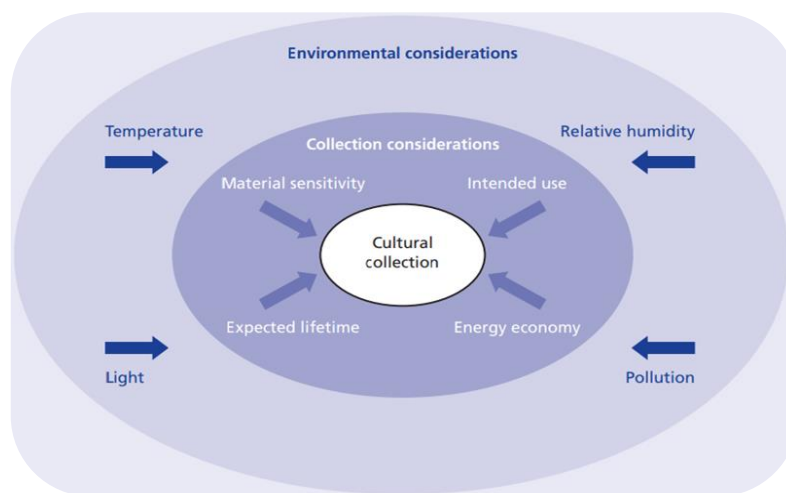

Figure 2.8 - Environmental considerations for cultural collections as set out in BSI, 2012

There are three main areas which will be of relevance in relation to this research, namely the effect of incorrect heating regimes and systems on hygroscopic materials, stained glass and pipe organs.

Hygroscopic materials include such items as wood (timber), paper, parchment, ivory, leather and bone amongst others (Camuffo, 2014). BSI (2012) describes a hygroscopic material as being a ‘material that absorbs moisture when the environmental humidity rises and loses moisture when the relative humidity drops’ (IS EN 15757:2010) (BSI, 2012). Timber is of particular importance to heritage buildings such as cathedrals since all these buildings contain large quantities of the material. All timber contains moisture which is important since changes to this create changes in the timber itself. The moisture content is dependent on the type of timber with green unseasoned wood containing up to 30% moisture. When the moisture content reaches equilibrium with the surrounding environment this is the equilibrium moisture content at a constant temperature. If the RH of the surrounding air changes, then either moisture is absorbed (causing swelling) or evaporated (causing shrinkage) by the timber until full equilibrium is again reached. Alternatively, as the T rises, the RH drops causing the timber to dry out by evaporation until equilibrium is again reached. How the timber reacts to changes in the environment is influenced by how it was cut, namely at a tangent to the tree growing direction, radially from the centre or longitudinally. Most planks of timber are cut longitudinally which includes most flooring which require long straight pieces of timber. Most timber used for building is treated and/or painted to negate these processes and much timber in Irish

cathedrals is old and has been covered in many layers of paint but more particularly varnish and this also restricts the amount of moisture loss and gain. However, Schellen et al., (2003) pointed out the substantial damage caused to a pipe organ, particularly the timber contained within it, by an unsuitable heating system in a Dutch church.

Books, paper and parchment, which are all found in cathedrals are also very susceptible to changes in RH (Camuffo, 2014). Current standards for museum collections were set by Thompson (1994) at 50% for RH and 20°C (68°F) for temperature. The 68°F was taken by many organisations as being 70°F. Davis (2006) in his later work reported that decreasing T from 70°F to 65°F (18.3°C) and RH from 50% to 45% significantly increased the lifetime of certain objects. Books are made up of not just paper but string, glue and cardboard and each of these is affected in different ways and at different rates by moisture content. The available literature relating to the effects of moisture changes on paper are primarily for museum collections. Inappropriate storage of books can also lead to mould growth, attack by insects and attack from outside pollution (Camuffo, 2014).

Stained glass windows are susceptible to all of the damaging agents such as heat, pollution, water, vandalism, shocks and vibration as are the buildings in which they are situated. They tend to be heavy, due to amount of lead, glass and solder which they contain and are generally held up using horizontal bars which means that all of the weight does not end up being exerted at the bottom of the window. However every one hundred years or so they have to be removed and repaired at considerable expense. For instance, what is known as the St. Patrick's window in St. Patrick's cathedral in Dublin was renovated in 2004 at a cost of €500K (stpatrickscathedral.ie). Recent changes to pollution aggravates the problems for stained glass windows with rain water containing many pollutants, especially in cities, which attack the lead causing it to oxidise and lose strength. Regular changes in the internal environment in cathedrals, and there are many examples in Chapter 5, can cause leaching of salts through the walls of the cathedral which cause weakening through corrosion where the tie bars for the windows are attached to the walls.



Figure 2.9 - A stained glass window, in an Irish church, showing salt damage near the tie bars

Bernardi et al. (2013) point out the problems with paint which was used in the earliest cathedrals, called grisaille. This paint was used as background and for outlines and is generally of a monochrome colour and it can crack where the paint meets the glass. The paper by Bernardi et al. discussed in particular the effect of protective glazing and generally concluded that if properly fitted and ventilated that the secondary glazing systems examined provided a protective environment for the stained glass which reduced the amount of rainfall to which the glass was exposed and therefore reduced the chemical reactions and moisture which this can promote. Bernardi et al. (2006) had previously discussed the damaging effects of condensation on stained glass windows. The Institute of Conservation (2011) in conjunction with English Heritage list the following problems which can be encountered with stained glass windows: bulging or sagging, faint paint, loss of paint outlines, leaking water, rattling glass, condensation – particularly in between secondary glazing, cracked glass or lead, often due to creep, loose copper ties, peeling mortar, white powder on the lead surfaces. They make the point that minimal intervention is usually the best conservation practice. Many of these changes are influenced by thermal and moisture changes.

Pipe organs are found in most cathedrals in Ireland and are also susceptible to changes in the internal environment in the buildings. They are made up of many different materials all of which react in different ways to environmental changes. Bordass and Bemrose (1996) lists the drying out of the air leading to lower RH as being a major factor which can lead to shrinkage of the timber in the instrument. This causes the instrument to go out of tune and for some notes to become unplayable as a result of sticking slider boards which are a delicate element of the instrument. They also mention stratification whereby the temperature at the top of the organ can be substantially higher than the temperature at, say, the keyboard, which can also cause severe problems, particularly to the metallic pipes. Schellen et al. (2003) found a 15°C difference between the top and the bottom of an organ in the Netherlands which they were monitoring. They found that the forced hot air system in this particular church produced a large degree of stratification which caused drying out of the instrument with resultant shrinkage of the timber parts. Camuffo (2014) states that such dryness cannot be mitigated by dehumidifiers since that would lead to condensation on cold surfaces and that the only solution for organs is either to lower the temperature in the cathedral as a whole or provide only local heating (Camuffo, 2014.). An EU funded project called the Sensor System to Detect Harmful Environments for Pipe Organs (SENSORGAN) (Bergstein et al., 2010) was designed to detect problems with potentially damaging environmental changes before they could cause damage to the instrument.

Corcoran (2009) carried out research in relation to the organ in St. Patrick's cathedral in Dublin with a view to determining if the environment around the instrument could be improved in order to avoid the costly retuning of the instrument. During the heating season with only nocturnal variations of

around 2°C, Corcoran discovered two major issues against a background of uniform background temperatures generally. Firstly, the air which the organ requires to operate and which is drawn in from outside, was much colder than the internal ambient which caused thermal shock in the instrument which almost certainly adversely affected the tuning of the instrument. Secondly, the cathedrals heating system was controlled by a single thermostat situated in the organ loft but the heating system could not maintain the set temperature (17°C) at that height and this did not prove to be an efficient system of temperature and by default, relative humidity, control.

The Institute of British Organ Building (IBO, 2003) sets out the problems faced by these instruments caused by the various types of heating systems. They suggest guidelines which they say should not be exceeded. For temperature, they recommend that when the church is empty the temperature should not be above 10°C and when the church is being used the temperature should not exceed 20°C. For relative humidity they recommend a band of between 55% to 75%. Like Corcoran, they highlight the problem of drawing in air from outside in order to power the organ and that this air is likely to be colder and more moist than the air inside the building. They also point out that blowers which are situated near to the boiler room may have the opposite effect and draw in warm or hot air which will cause a drop in RH and drying out of the various components which make up the organ. In Ireland it costs between €500 to €1,000 to tune an organ, so keeping the instrument at a more uniform temperature by thermostatic control, may be cheaper in the long term than frequently having to tune it as a result of inappropriate heating.

2.6 Conclusions

The literature review, specifically of relevance to this research and thesis, has shown that there has been a considerable amount of research carried out in the following areas:

- The importance of heritage buildings and how they should be preserved for future generations: a considerable amount of local and international legislation has been enacted for their protection but most of this legislation does not, yet, apply to religious buildings.
- How heritage buildings could become more environmentally friendly and sustainable and why they should do so: the UK is well ahead of Ireland in this regard and especially with regard to religious buildings. The Church of England has set targets for reducing its carbon footprint which are in line with UK government figures.
- Thermal comfort has been extensively researched: its importance to new developments, as a method of energy saving, has meant that increasing amounts of research are being carried out in this area. The move towards adaptable thermal comfort is well documented as is the difficulty of arriving at a universally acceptable method of measurement.

- The various methods of heat transfer and how they are calculated: these are well covered in the literature. Renewables are not part of this research and so the expanding amount of research in this area was not examined.
- The effect of heat and moisture on buildings and their contents: this is well researched and the adverse effects are well known.
- Individual and small groups of churches have been researched, often in great detail, but often from quite narrow geographical locations: the purposes of the research have covered such things as the effect of various heating types on artefacts and organs or on the buildings themselves.
- The issue of the conflict between thermal comfort, conservation and preservation of heritage buildings and their contents: this topic is well covered with the general approach being that as compromise is often required conservation should take precedence over thermal comfort.
- Whilst heritage buildings have been heated since the 1800s there is a limited amount of information and research about these early systems and why they were chosen for particular buildings.

The review of the literature appeared to show gaps in knowledge and research in relation to Irish cathedrals, which are the subject of this thesis, as follows:

- No research was found which discusses the internal thermal environment in Irish cathedrals and how this might affect the buildings and their contents.
- No research was found which discussed the heating and energy use of cathedrals or churches or examined if the needs of both might be different and why.
- Whilst a body of research has been carried on either individual churches or small number of churches in great detail in a number of countries, no research could be found where a larger group of heritage buildings, in this case cathedrals, were examined more broadly to understand if similarities and differences between them could be observed and acted upon for the benefit of them all.
- No comparison could be found on the changing uses to which these buildings (cathedrals) were being put and how this might be impacting on the buildings themselves.
- No research could be found in relation to a program for energy and greenhouse gas reduction in Irish cathedrals and churches.
- Costs were not part of this research but little evidence of the impact of cost of either fuel or installations could be found.
- Very little research was found relating to renewable energy sources for cathedrals and none for Irish cathedrals.

- No research or debate was found concerning the possible moral and ethical imperative for churches to reduce their energy consumption and carbon footprint, in Ireland.

It is intended that this research will fill some of the gaps in knowledge in relation to Irish cathedrals and will stimulate debate concerning the internal thermal environment extant in these buildings and how this impacts the people who use them.

Both the questionnaire and the data received from the loggers will fill many of these gaps in knowledge. The internal environment in 25 Irish cathedrals has now been examined with the help of over 2.4 million pieces of data. The completion of the questionnaire for all 57 cathedrals and the monitoring of 25 is a larger group of such heritage type buildings yet surveyed in Ireland or elsewhere. The changing use to which these buildings are now put and in particular the differences between the way in which Roman Catholic and Church of Ireland cathedrals are used, has been highlighted and may have relevance in other countries which have both protestant and Roman catholic cathedrals. The fact that little financial information was available may present opportunities for the owners of these buildings. The lack of attention to renewable energy sources and the lack of any targets for the reduction in greenhouse gas emissions may also present opportunities. It is hoped that the moral and ethical debate in relation to greenhouse gas emissions and renewable energy sources may be stimulated by the data gathered in this research. The complete lack of knowledge sharing also presents opportunities for the owners of these buildings to gain from good practice and ideas which have been tried and tested by others. This research has shown considerable weaknesses in the way in which these buildings are managed and again there are opportunities presented by this knowledge for the owners of the buildings.

3 Methodology

3.1 Introduction

Chapter 3 describes the selection of questions for the survey of all 57 cathedrals in Ireland, the methods used to gather and analyse the relevant data as well as showing how the equipment which was used was selected and on what basis the cathedrals which were monitored, were chosen. The placing of the equipment is described as well as how the various calculations and graphs were produced. The methodology chosen was based on the findings of Chapter 2 and adjusted to take account of relevant issues and differences presented by cathedrals in Ireland.

The research for this thesis was split between field research, that is the visiting of the cathedrals and the placing and removing of the equipment, and desk research, that is the literature review and the analysis of the data gathered.

The field research was, by its nature, constrained at times by local events and situations. It was not unusual, for instance, to arrive for an appointment to find that there was a funeral on in the subject cathedral which, of course, meant waiting until this event was over before entering the building. Sometimes people were not available for scheduled meetings at short notice, even though this might have involved travelling many hours to attend the relevant meeting. On occasions keys could not be found and on one occasion some hours were spent late at night trying to track down a set of keys so that the equipment could be removed, all of which had been previously arranged. It was often very difficult to make appointments with the relevant people in adjoining cathedrals which meant that no logical plan could be made with regards to optimising scheduling visits. This substantially increased the amount of travelling and time required to undertake the relevant visits to the 57 cathedrals. One cathedral felt initially unable to allow a visit but some 18 months later did so which was a considerable benefit as it is one of the largest and most important cathedrals in the country. The lack of information and why it was not available during the visits is discussed in Chapter 4.

Access to roofs and ladders were sometimes not possible which meant that the placing of equipment was compromised. This is the nature of field research where improvisation is often necessary, obstacles need to be overcome and approaches adapted to achieve the best possible, but perhaps not optimal, outcome. In the end all 57 cathedrals were visited and the questionnaires were completed. Achieving a 100% response to the questionnaires was considered very important as was the need to visit all of the active cathedrals, in order to achieve the research objectives. The field research could not have been carried out without the help and co-operation of the most helpful and often extremely stretched cathedral staff in the various locations.

As there are around 3,900 churches on the island of Ireland it was not felt that it would be practical to carry out an analysis of them all and it was felt unnecessary to do so as the same principles apply

to churches as to cathedrals. Some churches are actually larger than cathedrals but are similar in terms of age, use, size and construction. Since cathedrals are often but not always, the largest and most prominent churches, it was decided to concentrate on them as being the target buildings and with there being 57 active cathedrals it was felt that an in-depth investigation could be carried out on this number, even though they are geographically spread throughout the island of Ireland. It was decided to include all consecrated cathedrals in which religious services still take place even if those services were only occasional or by appointment. By targeting cathedrals it is possible to be specific and to include buildings of various sizes, ages, building types, shapes and with various heating systems, regimes and locations whilst at the same time achieving the academic objectives of the research.

The methodology was therefore broken down into the following components:

1. Compile a list of all the active cathedrals, of both Christian traditions, on the island of Ireland, and obtain all relevant background on them prior to each visit.
2. Devise and compose a suitable questionnaire to extract the relevant information during the subsequent visits.
3. Visit each of these cathedrals and complete the questionnaire during the visits (See Appendix 26 for a copy of the relevant questionnaire.).
4. Choose a representative number of these cathedrals based on their location, age, usage, size and construction, to be monitored.
5. Choose, procure and calibrate the equipment to be used.
6. Monitor these chosen cathedrals and record both the internal and external climatic environment, for at least one month during the heating season and monitor three cathedrals, for comparison, during the summer.
7. Analyse the results.
8. Make critical observations and recommendations.

The literature review had shown that temperature and relative humidity were the factors which had the greatest effect on the thermal comfort of the people using the cathedrals, the conservation of the buildings and the preservation of the artefacts held within them. The most common and most valuable artefact which was common in most cathedrals was the pipe organ and again T and RH are the factors most likely to affect these intrinsically and monetarily valuable musical instruments. In addition it was decided to measure the internal dimensions of the buildings as size has a direct bearing on the internal environment within the buildings, because the larger the building the more energy is required to heat it. It also enabled the cathedrals to be categorised by size when it came to analysing the results. The sizes were of necessity approximate as some of the buildings were complicated in geometry and ornate and would require a full architectural survey to measure their

internal dimensions with accuracy. It was felt that the dimensions which were recorded were sufficiently accurate to highlight the differences and common areas within the buildings. FLIR thermal images were also taken in attempting to discover if roofs were insulated since a ceiling showing a high T reading internally when the sun was shining, might indicate heat coming through from the outside which would suggest a lack of insulation. In most cases the cathedral staff who were interviewed, did not know if their cathedral had insulation, in the roof or elsewhere. This lack of insulation will lead to low T values and therefore high RH values in the area of the ceilings and roofs which in turn will lead to possible condensation problems and mould growth. Whilst air movements are acknowledged as being very important in determining the interior environment within cathedrals it was beyond the scope of this thesis to include such measurements. However it must be pointed out that all cathedrals have porches, of some description, at the entrances and this cuts down on draughts and air movements.

Agreement had to be reached with each of the owners and managers of the various cathedrals to visit the buildings and, where necessary, permission was sought to monitor T and RH over a period of approximately one month, when the heating was on. In three cases monitoring was undertaken when the heating was off, during the summer months. As each cathedral is treated as an autonomous unit it was necessary to contact each one separately in order to obtain the necessary permissions. Each diocese has one cathedral, with the exception of the Roman Catholic diocese of Cork and the Church of Ireland diocese of Dublin and Glendalough, which are discussed in Chapter 5. Over 100 visits were made to the various cathedrals involving an estimated 10K km of travel over a thirty six month period. Each of the 25 monitored cathedrals required 3 visits, one to examine the building and complete the questionnaire, one to place the equipment and one to retrieve it. In addition, a number of cathedrals were revisited to check measurements and in an attempt to gather further information, often as a result of the monitoring and also to check on what initially appeared to be erroneous results from the monitoring.

It was decided to monitor 25 of the 57 cathedrals as it was felt that this would give a representative sample of all of the cathedrals. Figure 3.1 has the breakdown by size of the monitored cathedrals compared to the total and a justification for this categorisation is given in Section 3.4.

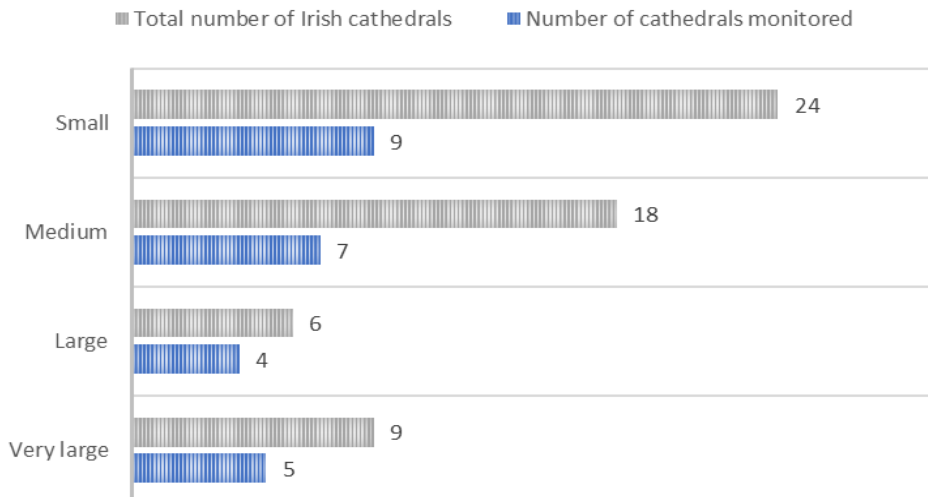

Figure 3.1 - Irish cathedrals categorized by size and monitored

Small cathedrals	Up to 10,000m ³
Medium cathedrals	Between 10,000 and 20,000m ³
Large cathedrals	Between 20,000 and 30,000m ³
Very large cathedrals	Above 30,000m ³

The reason why more very large and large cathedrals were monitored as a percentage (56% and 67%, respectively), than medium (39%) and small (38%) was because it was considered that these cathedrals, with their usage, variety of heating methods, regimes and resources, would be more representative of the buildings as a whole.

3.2 Selection of Instrumentation

Due to the nature of the buildings it was not considered possible to use any monitoring and recording equipment which would require fixing to the structures. All of the cathedrals in Ireland are either listed or protected buildings, depending on the jurisdiction in which they are situated. This means that they cannot be altered in any way without obtaining the necessary permits and permissions. Fixing instruments to the buildings, which would inevitably cause some damage, was not going to be possible or desirable. In addition the equipment selected had to be small enough not to be obtrusive to the ongoing operations within the cathedrals. They also had to be capable of being placed in areas where they would not be disturbed or even removed and at the same time be capable of taking relevant recordings. This meant that the equipment chosen would need to have its own internal and independent power source which had to last at least one month, which was the minimum period for which data was going to be collected and was the minimum period for which it was felt that reasonable conclusions and observations could be made. The same principles would apply to equipment placed both inside and outside the buildings although finding suitable locations, particularly for the externally placed equipment, proved to be a challenge. Ideally the internal equipment would have been placed at a height of between 1.5m and 2m since this is the height most relevant for human thermal comfort, but this usually proved impossible to do securely because the

equipment would have been quite obvious to the users of the cathedrals and could have been moved or removed either intentionally or unintentionally. In most cases it was possible to locate the loggers at a height of around 2m, although sometimes they were placed higher where no suitable secure locations could be found. Of the 130 loggers which were put in place only one was moved and this was subsequently returned. In particular the TinyTags, which could not be exposed to direct sunlight or rain, proved particularly challenging to place. Some cathedrals were not willing, understandably, to allow access to areas such as the roof and as a result three TinyTags were not placed in optimal positions and the data from them was not considered accurate enough, upon analysis, to be used. Internally, it was decided to use a T and RH data logger called an EL-USB-2+ (EL2) (Figure 3.1). This data logger, which is manufactured by Omega Engineering, has a proven track record of producing accurate data in a variety of locations. It was small enough to be able to be put in spaces which were not obvious and this reduced the risk of them being moved or removed. They have a long battery life, which can be up to one year depending on the frequency of readings which are required. They require no installation and, if necessary, can be fixed in place using temporary adhesive or tape which will cause no damage to either the logger or the surface to which it is attached. In addition they are light so further reducing any risk to the fabric of the buildings. Figure 3.2 shows the relevant data logger.



Figure 3.2 - Data logger used to monitor the temperature and relative humidity in the cathedrals

Table 3.1 - Specifications for the data logger Model EL-USB-2+.

Specification		Min.	Typ.	Max.	Unit
Relative Humidity	Measurement range	0		100	%RH
	Repeatability (short term)		±0.1		
	Accuracy (overall error)		±3	5	
	Internal resolution		0.5		
	Long term stability		0.5		
Temperature	Measurement range	-35		+80	°C
	Repeatability		±0.1		
	Accuracy (overall error)		±0.5	±2	
	Internal resolution		0.5		
Dew Point	Accuracy (overall error) (25°C, 40-100%RH)		±1.1		°C

Logging rate	every 10s		every 12hr	-
Operating temperature range	-35		+80	°C
1/2AA 3.6V Lithium Battery Life		1* year		

Table 3.1 gives the specification for the data logger. The logger has a temperature range of -35° to plus 80°C with an accuracy of $\pm 3^\circ\text{C}$. In relation to RH it will measure from 1-100% with an accuracy of $\pm 2\%$ (Byrne, 2013). The logger can be connected directly to a computer both to initialise the readings and to download the data once the monitoring is finished. The data is then presented on a Microsoft Excel© spreadsheet. Thermocouples were considered but were not found to be possible due to the fact that they would require to be permanently connected to a data logger or computer and obtrusive wiring would be needed. Whilst the thermocouples are relatively cheap to buy the computer and logging device are not and the risk of loss was considered too great. Also the recordings being taken were not expected to be particularly high or low and so thermocouples, which are good at recording extremes, were not considered necessary. Also cathedrals are large buildings and having to connect a number of instruments to a computer, by wire, was impractical.

Externally it was decided to use a Tinytag TGP-4510 data logger (Figure 3.3) which is a rugged outdoor T and RH monitor. This device has also had considerable successful use in the department. The specification for the TinyTag is given in Figure 3.4. This logger, like the USB 2, is independently powered, with a battery life, depending on the number of readings taken, of up to a year. It can also be set to take readings at various times and with adjustable start and stop times. The unit requires Tinytag software to be downloaded but the results can then be displayed on an Excel© spreadsheet. The unit does not need to be fixed to a building and it is small enough to be unobtrusive. This unit cannot be exposed to direct sunlight or it gives a false high reading. This was established by carrying out a test with two TGP-4510 USB loggers, one of which was exposed to direct sunlight and one which was protected from it, after unexpectedly high readings were recorded for two cathedrals. The fact that these units should not be exposed to direct sunlight or rain was not specified by the manufacturer on the manufacturer's data sheet and the external readings from two cathedrals were lost as a result of this.



Figure 3.3 - TinyTag Model TGP-4510. Used to monitor the temperature and relative humidity on the outside of the monitored cathedrals



Tinytag Plus 2 Dual Channel Temperature/Relative Humidity (-25 to +85 °C/0 to 100% RH) TGP-4500

Issue 11 : 17th October 2014 (E&OE)

Features		Physical Specification	
Total Reading Capacity	32,000 readings	IP Rating	IP68 water-proof (see notes)
Memory type	Non Volatile	Operational Range*	-25°C to +85°C (-13°F to +185°F)
Trigger Start	Magnetic Switch	Case Dimensions	
Delayed Start	Relative / Absolute (up to 45 days)	Height	34mm / 1.34"
Stop Options	When full After n Readings Never (overwrite oldest data)	Width	57mm / 2.25"
Reading Types	Actual, Min, Max	Depth	80mm / 3.15"
Logging Interval	1 sec to 10 days	Weight	110g / 3.9oz
Offload	While stopped or when logging in minutes mode	*The Operational Range indicates the physical limits to which the unit can be exposed, not the reading range over which it will record.	
Alarms	2 fully programmable; latching	Notes	
Reading Specification		Battery Type	SAFT LS14250 or LST14250; Tekool SBAA02P
Temperature		The logger will operate with other 1/2AA 3.6V Lithium (Li-SOCl2) batteries but performance cannot be guaranteed.	
Reading Range	-25°C to +85 °C (-13°F to +185°F)	Replacement Interval	Annually
Sensor Type	10K NTC Thermistor (Internally mounted)	Before replacing the battery the data logger must be stopped.	
Response Time	25 mins to 90% FSD in moving air	When replacing the battery, wait at least one minute after removing the old battery before fitting the new one.	
Reading Resolution	0.01°C or better	Data stored on the logger will be retained after a battery is replaced.	
Accuracy			

Figure 3.4 - Manufacturer's data sheet for TinyTag TGP-4500

3.3 Calibration

Not all of the USB 2 data loggers and TinyTags had been purchased at the same time and there were also concerns as to the battery life available in each one. As a result, the older batteries were replaced. Concerns also existed since, although each piece of equipment had the same name, not all looked exactly the same as some were older than others. It was therefore deemed essential that the units should all be labelled and calibrated. It was intended to leave the units in place for up to a month in each of the target cathedrals so accuracy was essential and all the more so because returning to the cathedrals to take further measurements was not considered logistically desirable.

It was decided to calibrate each instrument against a government-certified humidity/temperature measuring device which had itself been calibrated within the past six months. The equipment used was a Testo 625 as shown in Figure 3.5 , together with a Probe.



Figure 3.5 - (a) - Testo 625 Humidity and temperature measuring device and (b) probe

The manufacturer's data sheet for the product is shown in Table 3.2.

Table 3.2 - Testo 625 manufacturer's data sheet

General technical data			
Storage temperature	-40 to +85°C		
Operating temperature	-20 to +50°C		
Battery type	9V, block battery, +6F22		
Battery life	70h (without radio operation)		
Weight	195 g		
Dimensions	182 x 64 x 40 mm		
Housing material	ABS		
Warranty	2 years		
Sensor Types			
	Testo humid. sensor, cap.	NTC	Type K (NiCr-Ni) (Radio probes)
Measurement range	0 to +100% RH	-10 to +60°C	-200 to +1370°C
Accuracy ± 1 digit	±2.5% RH (+5 to +95% RH)	± 0.5°C	See probe data
Resolution	0.1% RH	0.1°C	0.1°C

It was considered prudent to compare the units in three different environments, namely in a commercial fridge, an environmental chamber and at normal room temperature which, in this case, was taken to be the concrete laboratory in the engineering department in Trinity College. The commercial fridge was used because of ease of access and because the unit was known to produce an average temperature of 6°C. The environmental chamber was used, since this could produce temperatures of up to 60°C with a range of RH between 0% and 100% as shown in Figure 3.6.



Figure 3.6 - Environmental chamber

T and RH during the calibration period in the chamber ranged from 15.1°C up to 36.5°C over a period of 42 minutes which was felt to be an acceptable range. RH over the same period ranged from 54.6% at a T of 15.1°C down to 15.2% with a T of 36.5°. Any unit, of which there were none, which did not match the Testo with a tolerance of $\pm 0.5^{\circ}\text{C}$ or 0.5%, was to be rejected and would not be used at the monitoring sites. The same criteria applied to the testing in the fridge and in the laboratory. Both the data loggers and the Tinytags were calibrated in the same way. The method used was to place the units and the Testo probe into the fridge and environmental chamber and then record the readings from the Testo, remotely. The probe, which was in the chamber/fridge with the loggers, sent the relevant information to the Testo 625, which was held by the researcher. Once the units were removed from the fridge, the environmental chamber and the concrete laboratory, the results from the Tinytags and data loggers could be downloaded to an Excel spreadsheet and compared with the manually recorded readings from the Testo. The readings were taken every five minutes.

It was discovered that TinyTags give false high T readings when exposed to direct sunlight. As a result of this, plastic containers were sourced which would protect the units from the elements, but still allow the free movement of air around them. This enabled them to be placed outside in the normal way without the risk of the casings of the units heating up, which appeared to be the source of the original problem. Having calibrated the units, new batteries were fitted to ensure that there were no power failures during monitoring.

The data loggers also had to be protected from direct sunlight entering the buildings through the windows and in fact two loggers may have been exposed to this light and heat source since their readings were higher than they were expected to be. A test was done by placing a logger on a window in an office in Trinity College to monitor the effects of direct sunlight on the USB logger and, as the graph in Figure 3.7 shows, the peaks are clearly shown when the sunlight hits the logger, for instance on the 13, 14, 20, 23, 24, 27 of January and on 1 February 2017.

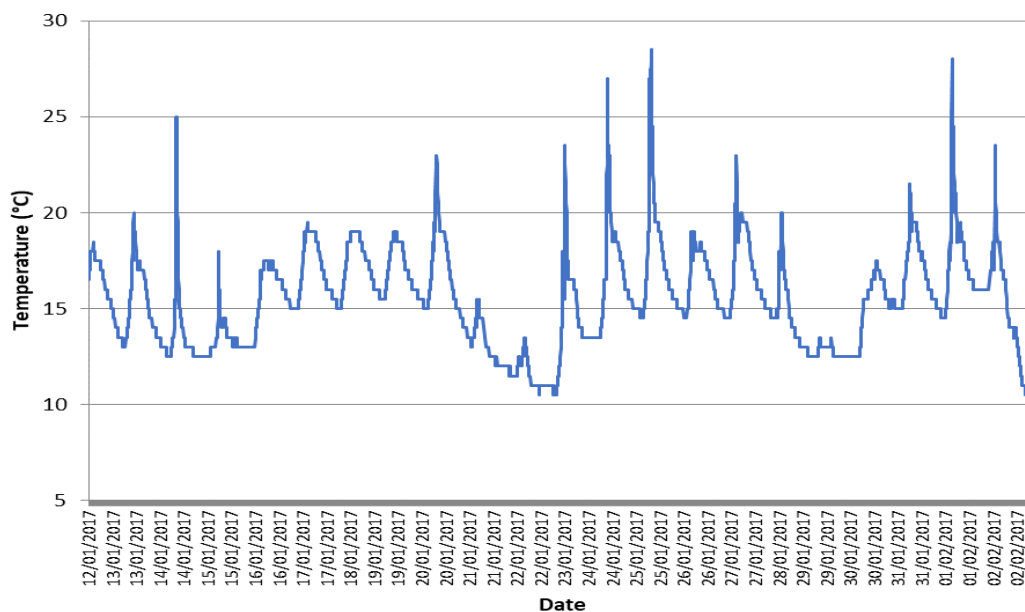

Figure 3.7 - Sunlight test on a data logger in Trinity College

The temperature in Ireland does not reach 27°C at 7am on a January morning and hence, it is possible to conclude that the loggers are also affected by being exposed to direct sunlight. This explains the unusually high T readings found on two loggers, namely in Kildare and Armagh cathedrals, during the monitoring process.

It was important to avoid placing the loggers where they would be exposed to direct artificial heating such as above a radiator, in line of a radiant heater or near candles. As they could not be attached to the buildings in any way it was sometimes expedient to attach them to non-heat emitting electrical equipment such as wall speakers, using cable ties.

In order to measure the size of the cathedrals a laser measuring device was used on site to measure the principle dimensions.

3.4 Choosing the Cathedrals to be monitored

All of the 57 active cathedrals on the island of Ireland were visited and the questionnaire, which is shown in Appendix 26, was completed, as far as possible. It was originally intended to monitor three cathedrals for a year in order to test the hypothesis that thermal comfort was being achieved at the expense of conservation and preservation and because it was felt that a full year’s monitoring would give evidence of seasonal variations in the internal environment of the buildings. However when it was recorded that in Ireland the outside T remained relatively stable for a long period over the winter, it was decided to monitor a much greater number of cathedrals but for a shorter period. One month in the heating period would be similar to any other month in the heating period in terms of external temperature ranges provided that the beginning and end of the heating period were avoided. in other words Spring Likewise for the three cathedrals which were monitored during the

summer, it was felt that one month for each cathedral was sufficient to arrive at accurate and relevant data.

Table 3.2 shows the breakdown of the cathedrals by size as well as location and patronage (RC or CI). Four size categories were chosen, as discussed in Chapter 4, ranging from the very large cathedrals (more than 30,000m³ in volume) to the relatively small (less than 10,000m³). In addition the cathedral visits showed great diversity amongst them and it was considered that it would not be possible to choose as few as three that would be representative of the whole.

Table 3.3 - List of cathedrals categorised by size

City	Name	Size (m ³)
VERY LARGE (> 30,000M³)		
Galway*	Our Lady Assumed into Heaven & St. Nicholas (RC)	44,000
Newry	St. Patrick & St. Coleman (RC)	41,400
Cobh	St. Coleman's (RC)	38,000
Armagh*	St. Patrick's (RC)	37,000
Belfast*	St. Anne's (CI)	37,000
Monaghan	St. Macartan's	36,000
Dublin*	St. Patrick's (CI)	35,000
Kilkenny*	St. Canice's (CI)	35,000
Limerick	St. John's (RC)	32,200
LARGE (≤ 30,000M³ AND > 20,000M³)		
Mullingar	Christ The King (RC)	29,000
Dublin*	Pro Cathedral (RC)	25,000
Derry	St. Eugene's (RC)	23,000
Limerick*	St. Mary's (CI)	22,500
Killarney*	Assumption of the Blessed Virgin Mary (RC)	22,500
Longford*	St. Mel's (RC)	22,500
MEDIUM (≤ 20,000M³ AND > 10,000M³)		
Cork*	St. Fin Barre's (CI)	19,400
Waterford	Most Holy Trinity (RC)	17,700
Cavan	St. Patrick & St. Phelim (RC)	17,500
Dublin*	Christ Church (CI)	17,000
Sligo	Immaculate Conception (RC)	17,000
Letterkenny	St. Eunan & St. Columba	16,000
Thurles	Cathedral of The Assumption (RC)	15,500
Belfast*	St. Peter's (RC)	15,000
City	Name	Size (m ³)
Enniscorthy	St. Aidan's (RC)	15,000
Tuam	Cathedral of The Assumption (RC)	14,500
Kilkenny*	St. Mary's (RC)	13,500
Ballina	St. Muredach's (RC)	13,500
Cork*	St. Mary & St. Anne Cathedral(RC)	13,000
Ballaghaderreen	Annunciation and St. Nathy (RC)	12,250

Armagh*	St. Patrick's (CI)	12,000
Cloyne	St. Coleman's (CI)	12,000
Waterford	Christchurch (CI)	11,000
Derry*	St. Columb's (CI)	10,000
SMALL ($\leq 10,000\text{M}^3$)		
Downpatrick	Holy Trinity (CI)	9,700
Carlow*	Cathedral of The Assumption (RC)	9,000
Tuam	St. Mary's (RC)	8,000
Loughrea*	St. Brendan's (RC)	7,700
Kildare*	St. Briget's (CI)	7,500
Ennis	St. Peter & St. Paul (RC)	7,300
Skibereen*	St. Patrick's (RC)	5,400
Lisburn	Christ Church (CI)	5,300
Dromore	Christ The Redeemer (CI)	4,500
Lismore*	St. Carthage's (CI)	4,300
Killaloe*	St. Flannan's (CI)	4,140
Cavan	St. Fethlimidh's (CI)	4,000
Sligo	St. Mary & St. John (CI)	4,000
Enniskillen*	St. Macartin's (CI)	3,800
Cashel	St. John & St. Patrick (CI)	3,500
Rosscarberry	St. Fachtna's (CI)	3,200
Clonfert	St. Brendan's (CI)	2,700
Trim	St. Patrick's (CI)	2,400
Clogher	St. Macartan's (CI)	2,350
Raphoe*	St. Eunan's (CI)	2,200
Killala	St. Patrick's (CI)	2,025
Ferns	St. Edan's (CI)	1,660
Old Leighlin*	St. Laserian's (CI)	1,600
Kilfenora	St. Fachtna's (CI)	1,060

* = Monitored

The monitoring of 25 of the 57 cathedrals, for at least one month resulted in over 2.4 million readings being taken. These readings were manually examined to calculate the range and average temperatures and humidity and, when the heating was switched on, the rate increase of T (in °C/hr) for each cathedral. There were no available computer programs which could recognise the time interval when the T increased due to heating and then decreased again for each logger, which is why this was done manually. This was simply a case of visually observing the outputs for each logger and noting when the T started to rise sharply, indicating an artificial heat source. The time and T was again noted when the T started to fall suddenly and the differences calculated. Each logger produced approximately 16,000 readings arising from a reading being taken every five minutes for a month, and each cathedral produced about 96,000 readings. The 5,000 or so manual calculations, the time/temperature differences enabled them to be plotted on a graph. The calculations were

randomly checked for accuracy and consistency and deviations from the normal trends were rechecked and explained.

Of the 150 loggers and TinyTags put in place only two TinyTags and two loggers failed either due to being put in direct sunlight or because the batteries failed. A further two loggers produced erroneous internal results as a result of being exposed to direct sunlight coming through a window on the opposite side of the relevant cathedral or because they were inadvertently situated too close to an artificial heat source. This gave a failure rate for the Tinytags of 8% (2 in 25) and for the data loggers 3% (4 in 135) which is deemed to be acceptable.

Subsequently each cathedral which was monitored was sent a full set of graphs for each logger and for the Tinytag, a graph showing the increase per hour of T in °C/hr and a map of their cathedral showing the locations for the TinyTag and the loggers. The cathedrals chosen to be monitored were selected after the initial visit to assess their suitability for the placing of the relevant equipment, as well as to assess the willingness of the owners and managers of the buildings for such monitoring to take place. They were rightly concerned that no damage should be done to the buildings and that there should be no disturbance or distractions caused to those using the buildings. Once the suitability of the building had been established and the necessary permissions obtained, the equipment was installed, and a detailed map of the locations was produced (to aid retrieval) and results interpreted. The building was then visited again to remove the equipment and download the data. The dates when the cathedrals were monitored are shown in Table 3.4.

When deciding which cathedrals should be monitored a number of factors were taken into account. (1) *Religion*: it was important to achieve a good cross section of cathedrals from amongst the two religions to ensure even representation. Both religions have very different uses for their cathedrals and this needed to be represented. (2) *Size*: size is the way in which the cathedrals have been examined in Chapter 5 and it was considered to be important to monitor across the size ranges. Obviously the larger the space to be heated the more energy is required and so cathedrals were chosen from each of the size ranges. The size ranges have convenient breaks between the categories of approximately 10,000m³ and this facilitated the choosing of those to be monitored by making sure that a sufficient number of cathedrals from every size band were chosen. (3) *Heating system/regime*: where on initial inspection cathedrals were found which had either an unusual heating system and/or regime or had one which was well represented, then these cathedrals were chosen for monitoring. (4) *Location*: this was considered when choosing the cathedral to ensure that cathedrals from all parts of the island were chosen, where possible. (4) *Age*: a representative sample across the ages was taken since the way in which the buildings were built and hence the differences in such factors as thermal mass were considered to be important to take into consideration. (5) *Artefacts*: these are very susceptible to changes in temperature and relative humidity and where a cathedral was found to have a number of these articles, they were included in the list for monitoring. Taking

these factors into account, and taking into account that 44% of the total number of 57 cathedrals were monitored, it is considered that a reasonably representative sample has been achieved.

A limitation of the research was that only a relatively small number of data loggers were available for each building, namely 5 and 1 TinyTag. This resulted in the cathedrals being monitored over a long period making comparisons more difficult than if all of the cathedrals had been monitored at the same time. This however would have required considerable additions to the manpower available. Ideally large numbers of data loggers would have been available so that each building could be measured at the same time and at various heights within the buildings and the data could then be collected, over a much longer period, remotely. This is why it is recommended under section 6.5 on further research, that exactly this should happen but to a smaller number of buildings.

Table 3.4 - Monitoring dates for the 25 cathedrals

Cathedral monitoring dates

Name of cathedral		2015					2016										2017				
		Feb	Mar	Apr	Nov.	Dec.	Jan.	Feb.	Mar.	June	July	Aug.	Oct.	Nov.	Dec.	Jan.	Mar.	Apr.	May	June	
Dublin, Christ Church	Winter	27		15																	
Dublin, St. Patrick's		27		16																	
Longford, St. Mel's			5	22																	
Galway, Our Lady Assumed into Heaven			13	17																	
Dublin, Pro cathedral					6	7															
Belfast, St. Peter's					12	11															
Derry, St. Eugene's					9	9															
Belfast, St. Anne's					12	11															
Armagh, St. Patrick's (CI)					12	11															
Kildare, St. Bridget's						14		5													
Limerick, St. Mary's						16		7													
Killarney, St. Mary's						15	29														
Kilkenny, St. Canice's	Winter					17		3													
Kilkenny, St. Mary's						17		3													
Enniskillen, St. Macartin's							30		13												
Cork, St. Mary's								8	14												
Cork, St. Fin Barre's								8	14												
Dublin, Christ Church	Summer									10		6									
Armagh, St. Patrick's (RC)	Summer									20		12									
Kilkenny, St. Canice's	Summer									17		11									
Armagh, St. Patrick's (RC)	Winter												25	25							
Old Leighlin, St. Laserian's															1	11					
Lismore, St. Carthage's															1	11					
Killaloe, St. Flannan's																	12	30			
Raphoe, St. Eunan's																	15	27			
Carlow, Cathedral of The Assumption																		7	10		
Skiberreen, St. Patrick's																		18	17		
Loughrea, St. Brendan's																			1	1	

3.5 Installation of Equipment

There were five data loggers and one Tinytag available for monitoring each cathedral. This was considered to be sufficient to establish the internal thermal environment in the chosen cathedrals. It was hoped to install the data loggers and Tinytags in similar positions in each cathedral but this, for practical reasons, did not prove possible. It would have been preferable to install the data loggers between 1.5m and 2m from the ground, since this is the space most affected by issues of thermal comfort. Ideally the loggers would be placed with a similar number in the nave, sanctuary and side chapels to cover the areas most used in the cathedrals during services. However it was found that the internal layouts and in particular the differences in internal fittings, sometimes made this impossible. Difficulty was found in securing places where the loggers could be placed where they would neither be seen, disturbed nor removed. As previously stated, fixing the loggers, in any way, to the buildings was not an option since this would cause damage to the fabric of the buildings and would not have been acceptable to either party. Consequently the loggers, generally, were placed higher than was considered ideal. As stated previously it was also essential to ensure that the loggers were not placed anywhere near an artificial heat source. It was often necessary to place the loggers in the side aisles since it was not possible to find suitable attachment points in the nave. It is accepted that fewer people sit in the side aisles than the nave and this is accepted as an unavoidable limitation of the data gathering process. Ideally most of the loggers would have been placed in the nave since this is the area where most people sit but the lack of suitable locations for the loggers precluded this being done. Placing loggers mostly in the side aisles was not ideal but was the only practical solution and there was a consistency about the placing of the loggers. The side aisles are likely to experience air movements which are different to those experienced in the nave particularly caused by the location of the windows in the side aisles.

For those cathedrals with underfloor heating it would have been ideal to have placed a logger actually on the floor which would have given more accurate information as to when the heating was switch on and off and also given better readings of the actual floor temperature. However a logger was inadvertently removed by the cathedral in one of the early monitoring sessions when this was done and the experiment was not subsequently repeated.

The placement of the Tinytags externally proved particularly difficult to achieve as they had to be high enough that they would not be stolen or disturbed but also shielded from direct sunlight in order to produce valid readings. Two areas were subsequently found to be suitable. The first was in a tower or belfry, where the cathedral had one. It was found that these often had wooden louvres which allowed the exterior environment to enter the tower without exposing the Tinytag to direct sunlight. It was also possible to protect the unit from rain without affecting the RH readings. Where access to the towers was either not possible or considered too hazardous to be able to place the

equipment securely, it was often found that placing the equipment at the entrance to the porch of the cathedral proved satisfactory since they were exposed to the elements and yet were accessible and protected from direct sunlight.

Placing the TinyTags in belfrys or towers or in the porches of cathedrals could be considered as being inside and not outside. These places however, whilst being protected from direct sunlight and rainfall, were exposed to the external elements. For instance, the TinyTag in Killarney cathedral was placed some 30m up in the cathedral tower which was open on all four sides and it was attached to an internal ladder which in turn was attached to an outside wall. It is considered that accurate outside temperature and relative humidity readings were recorded by this logger. Likewise the TinyTag in Kilkenny (Church of Ireland) cathedral was placed just inside the cathedral porch where it was protected from direct sunlight and rainfall but was otherwise entirely exposed to the outside environment. Where external doors were opened and closed on the outside of the porch then this did not prove as successful, as the readings from Armagh CI cathedral show. Where access to the roofs was possible then the TinyTag was placed inside a ventilated plastic container and fixed to the building with a cable tie to prevent it being blown or washed away.

Having gathered the data it was necessary to calculate the overall range and average temperature when the heating came on and immediately afterwards in addition to calculating the increase in T per hour in each monitored cathedral. The graph for each cathedral is attached to the relevant appendices and discussed in Chapter 5. This data made it possible to see how quickly the various loggers heated up and, taken with the floor plan of each cathedral which shows where the loggers were placed, it enabled additional, although limited, information to be gained concerning the spread of warm air throughout the building and the effectiveness of the heating.

3.6 Analysis

An example of a graph produced by the data loggers is given in Figure 3.8. It displays temperature, dew point and relative humidity for one logger in, in this case, St. Patrick's cathedral in Dublin. Each of these readings from these individual loggers in each of the 25 cathedrals are displayed in the Appendices numbers 1 to 25.

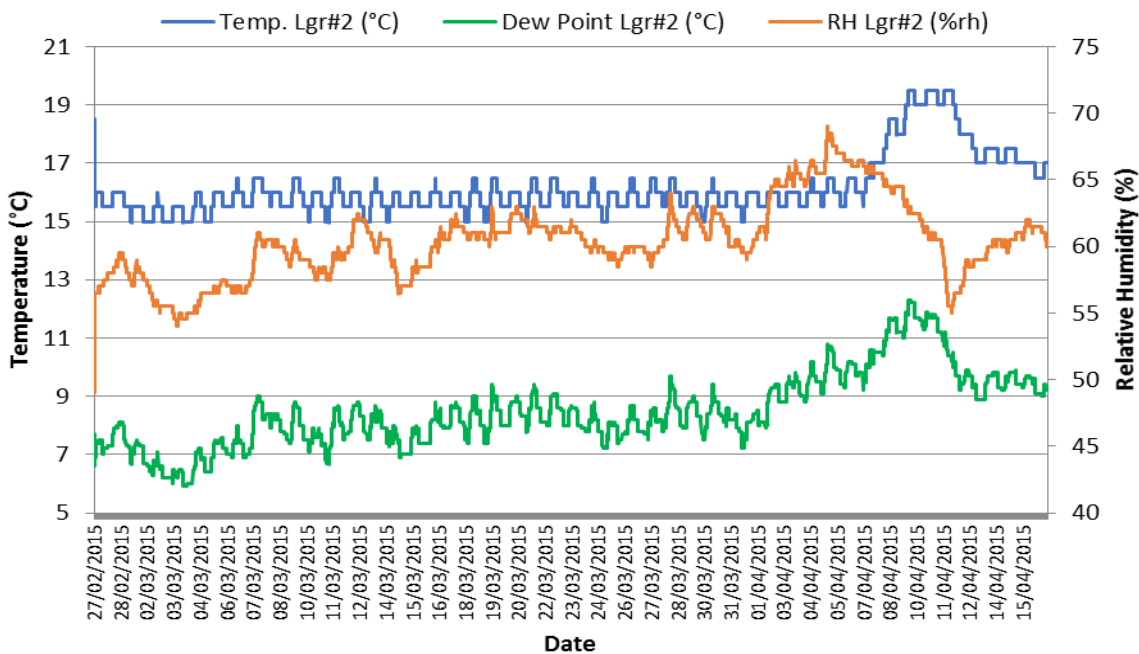

Figure 3.8 - Sample graph for logger 2 in St. Patrick's Cathedral, Dublin

It was possible to amalgamate all of the loggers for one cathedral onto one graph which produced typically a graph such as in Figure 3.9. Individual graphs were produced for each logger, which can be found in Appendix 2.

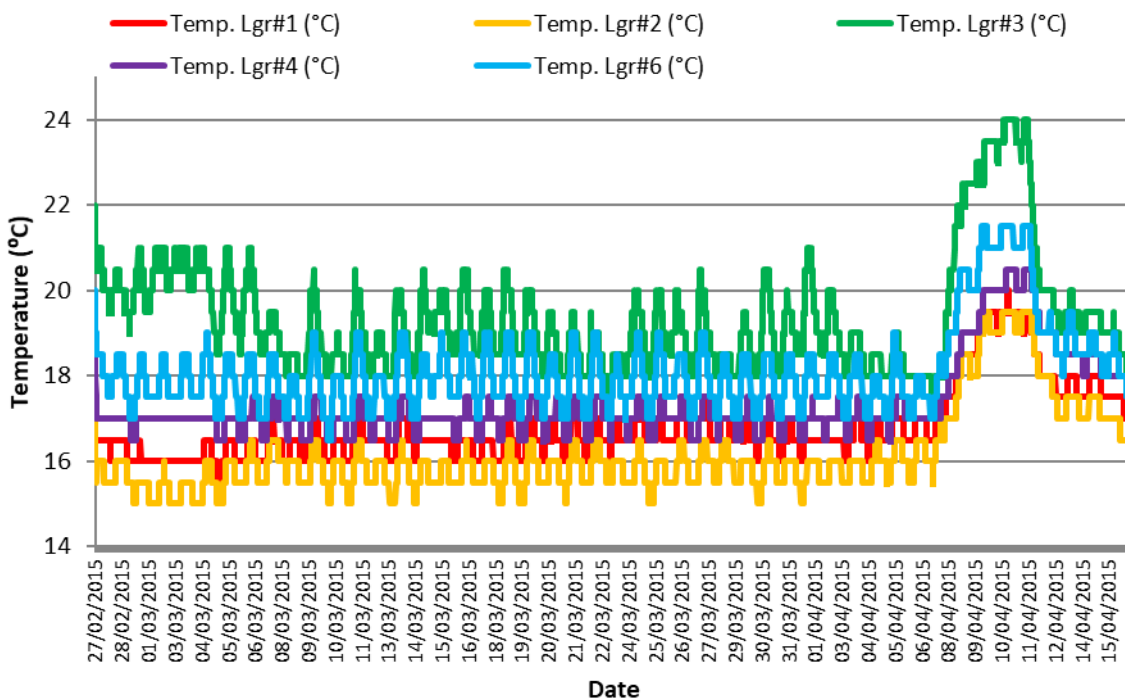

Figure 3.9 - Sample consolidated logger graph for T in St. Patrick's Cathedral, Dublin

From the data acquired from the loggers, it was possible to produce a graph with the rate of increase in temperature per hour for each cathedral(°C/hr). The calculations were done for each one of the loggers installed and a table exemplifying the method can be seen below (Table 3.5). A reading was taken when the heat started to increase and again when it started to decrease. The increase in T was

noted as well as the time taken for the rise to take place. Based on these figures, it was possible to calculate the rate of T increase per hour for each cathedral and an example of the plotted figures are illustrated in Figure 3.10.

Table 3.5 - Sample calculations for producing the rate of T increase per hour

St. Peter's Belfast RC Cathedral					
Date	T when heat comes on	T when heat comes off	T rise	Time taken for T to rise	Rate of T increase per hour
LOGGER 12					
15/11/2015	15.0 °C	16.5 °C	1.5 °C	3.25 h	.46 °C/h
22/11/2015	11.5 °C	13.0 °C	1.5 °C	2.55 h	.59 °C/h
29/11/2015	13.0 °C	14.0 °C	1.0 °C	2.10 h	.48 °C/h
06/12/2015	15.0 °C	16.5 °C	1.5 °C	2.40 h	.63 °C/h
Average			1.38 h	2.58 h	.54 °C/h
LOGGER 13					
15/11/2015	16.0 °C	17.0 °C	1.0 °C	1.50 h	.67 °C/h
22/11/2015	12.0 °C	13.5 °C	1.5 °C	2.45 h	.61 °C/h
29/11/2015	13.5 °C	15.0 °C	1.5 °C	2.50 h	.60 °C/h
06/12/2015	15.5 °C	17.0 °C	1.5 °C	3.00 h	.50 °C/h
Average			1.38 h	2.36 h	.59 °C/h
LOGGER 14					
15/11/2015	15.0 °C	17.0 °C	2.0 °C	4.35 h	.46 °C/h
22/11/2015	12.0 °C	13.5 °C	1.5 °C	3.10 h	.48 °C/h
29/11/2015	12.5 °C	14.5 °C	2.0 °C	4.25 h	.47 °C/h
06/12/2015	15.0 °C	16.5 °C	1.5 °C	3.00 h	.50 °C/h
Average			1.75 h	3.68 h	.48 °C/h
LOGGER 15					
15/11/2015	16.0 °C	17.5 °C	1.5 °C	2.40 h	.63 °C/h
22/11/2015	12.5 °C	14.0 °C	1.5 °C	3.10 h	.48 °C/h
29/11/2015	13.0 °C	14.5 °C	1.5 °C	3.35 h	.45 °C/h
06/12/2015	15.5 °C	17.0 °C	1.5 °C	2.55 h	.59 °C/h
Average			1.50 h	2.85 h	.54 °C/h
LOGGER 16					
15/11/2015	16.5 °C	18.0 °C	1.5 °C	2.30 h	.65 °C/h
22/11/2015	13.0 °C	14.5 °C	1.5 °C	4.00 h	.38 °C/h
29/11/2015	14.0 °C	15.5 °C	1.5 °C	1.55 h	.97 °C/h
06/12/2015	16.5 °C	17.5 °C	1.0 °C	1.50 h	.67 °C/h
Average			1.38 h	2.34 h	.67 °C/h
It takes an average 2.4 hours to raise the temperature (T) by 1.8°C or .52°C/h.					

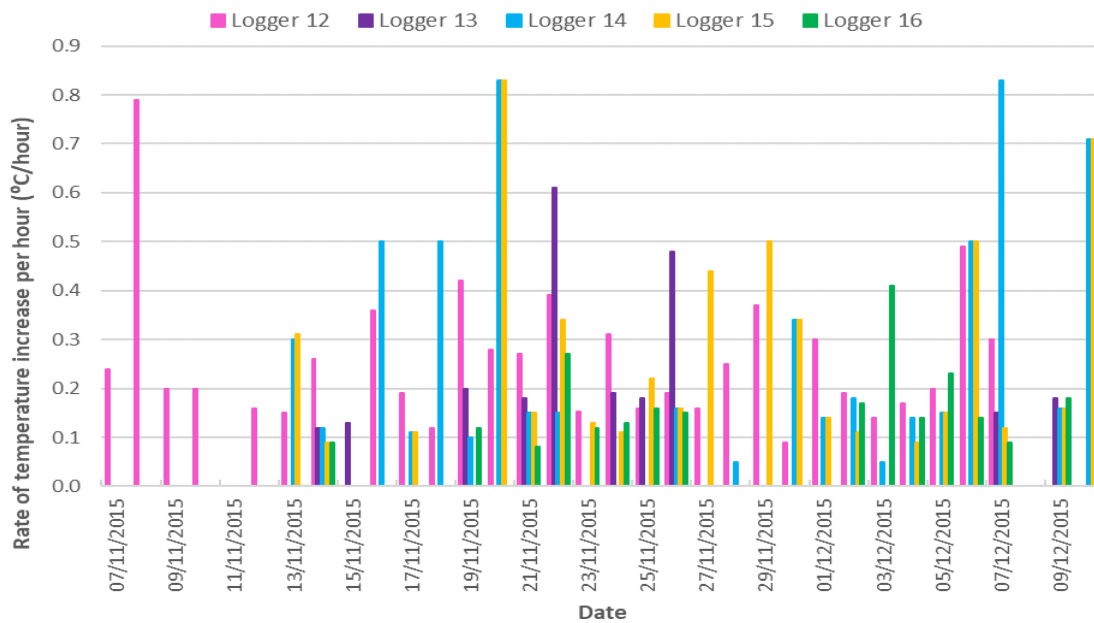

Figure 3.10 - Consolidated graph showing the rate of temperature increase in °C/hr for all of the loggers in St. Peter's cathedral, Belfast

Finally the TinyTag which can also download the data directly onto a spreadsheet produces typically a graph such as in (Figure 3.11) which is an example from St. Mary's cathedral, Limerick.

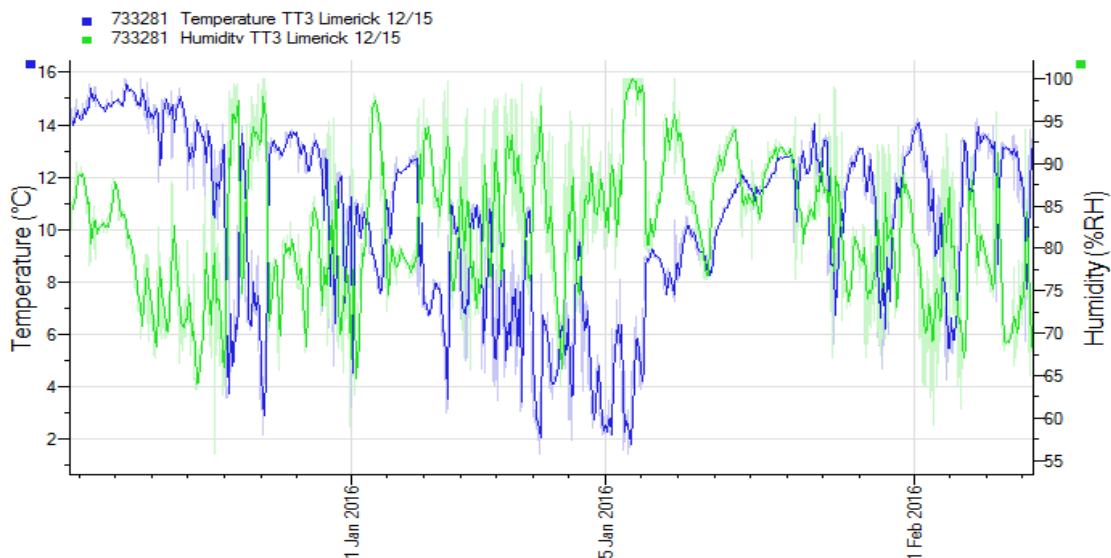

Figure 3.11 - TinyTag readings of external temperature and relative humidity from St. Mary's cathedral, Limerick

3.7 Questionnaire

The questionnaire was an essential part of this research project since an initial review of the available literature had shown a lack of information about research into the internal thermal environment in Irish cathedrals. An early decision was made to visit each of the 57 cathedrals in Ireland and therefore it was logical to complete the questionnaires, as far as possible, during the visits. The primary task when compiling the questionnaire was to ensure that it helped to fulfil the research objectives and the questionnaire was designed to do this. The population or sample had already

been decided, namely that it was all of the 57 active cathedrals on the island of Ireland. The method of completing the questionnaire had also been decided in that it would be the researcher who would complete it during these visits and this ensured that 100% of the questionnaires were completed. Personal measurements and observations were considered vital so that visiting in person not only ensured a 100% response but improved the reliability and consistency of the data gathered. The questionnaire was designed so that all of the questions were closed or factual. Opinions and ratings were not sought as it was felt that these could, if required, be ascertained during the interview with the relevant people. The questionnaire was longer than would have been desirable had it been posted out or sent on-line but it contained all of the questions which the researcher considered were important in order to gain an accurate assessment of each of the cathedrals. The questions were placed in a logical sequence and generally required only a single response. Having completed the questionnaire it was trialled on a small number of cathedrals and amended where necessary. It was at this point that it became obvious that one person in each cathedral was unlikely to have all of the answers to the questions. None the less it was decided not to alter the questionnaire but where possible, to seek additional information from others within and connected to, the cathedrals, when possible.

The question arose as to the ethics and confidentiality of the information being sought and how it was being obtained. It was not considered that ethics was an issue due to the factual nature of the information being requested. Confidentiality was a significant issue perhaps especially with regard to the financial information being sought. Many cathedrals did not have available the financial information requested while some chose not to disclose it. In the end it was decided that there was insufficient response to the financial part of the questionnaire to sensibly include it. This is obviously an area for further research which could be instigated by the highest authorities in the two traditions.

The two primary methods of obtaining the data from the cathedrals, namely the questionnaire and the data monitoring enabled the first two objectives to be met. These were to compile a data base about the buildings and to monitor, in great detail, 25 of them. The methodology chosen made it possible to achieve these objectives. The methodology also made it possible to conclude that objective three, namely the grouping of similar cathedrals and perhaps suggesting an optimum heating system for each group, was not possible due to the variety and complexity of the buildings and the ways in which they are used. In the unrealistic situation where finance was not an issue and completely new heating systems could be installed, then the data collected would certainly help in arriving at an optimum solution for a particular group of cathedrals but it is more likely to be of use when large scale renovations are taking place and new heating solutions are being explored.

4 Irish Cathedral's Details

4.1 Introduction

Of the four major Christian churches in Ireland, namely the Roman Catholic church, the Church of Ireland, the Methodist and Presbyterian churches, only the Roman Catholic church and the Church of Ireland have cathedrals and so this research only considered cathedrals owned by the latter two traditions. Over a period of three years all of the 57 active cathedrals in Ireland were visited, some several times and a detailed questionnaire completed via face-to-face interviews and on-site observations as far as possible, during the visits, for each cathedral. By completing the questionnaires at the time of the visits it was possible to obtain a 100% success rate for the return of the questionnaires. A copy of the questionnaire can be found in Appendix 26. It was originally intended to monitor three cathedrals for a whole year and compare the results. However given the diversity recorded by the questionnaire it was decided that it would not be possible to choose three cathedrals which would have been representative of all of the cathedrals and so the decision was taken to monitor 25 cathedrals, based initially on size category, for a period of at least one month each. Furthermore three of the cathedrals would be monitored during the summer months when the heat was off to better understand the effect of thermal mass and internal conditions in those buildings.

In most cases the questionnaire was completed with the help of the cathedral's sexton or sacristan and the amount of information which they were able to give, varied. Ideally these questionnaires would have been completed by talking to a number of different people within each cathedral. For example, the bishop could have revealed his future plans for the cathedral and an assessment could then be made as to the future energy needs and how these might have impacted on the internal environment. The diocesan architect should have detailed plans of each cathedral available and would have been able to specify, for instance, if any parts of the building were insulated. He/she would also have been able to explain how and why particular decisions were reached in relation to the maintenance, repair and/or replacement of any part of the heating system. The diocesan accountant could have explained more about the heating and energy costs as well as why a particular fuel is used. The administrator in each cathedral could explain in more detail, than was usually available, about the day-to-day running of the cathedral and why particular heating regimes had been adopted, all of which have an impact on the internal environment within the cathedrals. Members of the congregation could have been questioned to see if they were satisfied with the level of heating within the cathedral and finally the relevant heating engineers could have been asked more details about the heating system design and its operations.

However, to interview that number of people for each of the 25 cathedrals was not practical from either a cost or time point of view. In fact it proved difficult to arrange appointments with anyone in

some of the cathedrals as they can be understaffed and also staff may have responsibility for a number of buildings within the diocese, not just the cathedral. This further limited the time which they had available, to answer questions. By only interviewing the sextons and sacristans it was accepted that the amount of information available from them could be limited but it was felt that by monitoring 25 cathedrals such gaps in knowledge could partly be covered from accurate monitored or published data. In a number of cases it was possible to meet with the administrators, clergy and accountants and much valuable information was obtained from these, often unexpected, meetings.

One thing which became apparent during the visits was how little information sharing there is between the cathedrals. Each cathedral has its own administration, makes its own purchasing decisions and no evidence was found of any type of co-operation in this respect of cathedral life. Much valuable information could be gained by having a forum for the sharing of information about such things as energy source, costs and utilisation. This was a major finding of the research and presents many opportunities for the owners of the buildings to co-operate and share best practice ideas. Chapter 6 suggests an all-Ireland inter faith forum as a suitable vehicle to achieve this.

The following observations are derived from a study of the data collected in the questionnaire. There are some gaps in the information supplied, usually because the facts were not known but occasionally, especially regarding costs, because the cathedral administrators did not always, understandably, for reasons of confidentiality, wish to share this information. Sometimes the costs, which specifically and only related to the cathedral, were not known because these costs were amalgamated with heating and energy costs from other ecclesiastical buildings on the same site. Other data collection issues are highlighted in the relevant sections.

4.2 History

4.2.1 Age

Whilst it is acknowledged that the age of the cathedrals does not influence the current internal environment within them, it is worth showing that Ireland has a large number of small, relatively new cathedrals. In order to compose the following graphs the date of consecration was taken as the age for each cathedral since this date is known with some accuracy. It is acknowledged that this date does not always reflect the actual date of completion of the buildings and some cathedrals, largely for historical and funding reasons, were built over long periods. Prior to the Dissolution of the Monasteries in 1537, all churches and cathedrals in Ireland were owned by the Roman Catholic church since that was the only Christian tradition in Ireland, or indeed anywhere else prior to the Reformation of 1517 to 1647. The effects of this are shown in Figure 4.1 which shows the position in Ireland prior to the Reformation.



Figure 4.1 - Age profile of cathedrals in Ireland by first consecration date before the Reformation

However after the Reformation the situation is presented in Figure 4.2 and what is noticeable is the number of Roman Catholic cathedrals built between 1800 and 1900. Considering the turbulent history of Ireland during the period and the fact that what became known as the Great Famine between 1846 and 1852 also occurred during this period, this perhaps shows the importance of that religion to the people who managed to raise the necessary funds to build these iconic buildings which are the subject of this research.

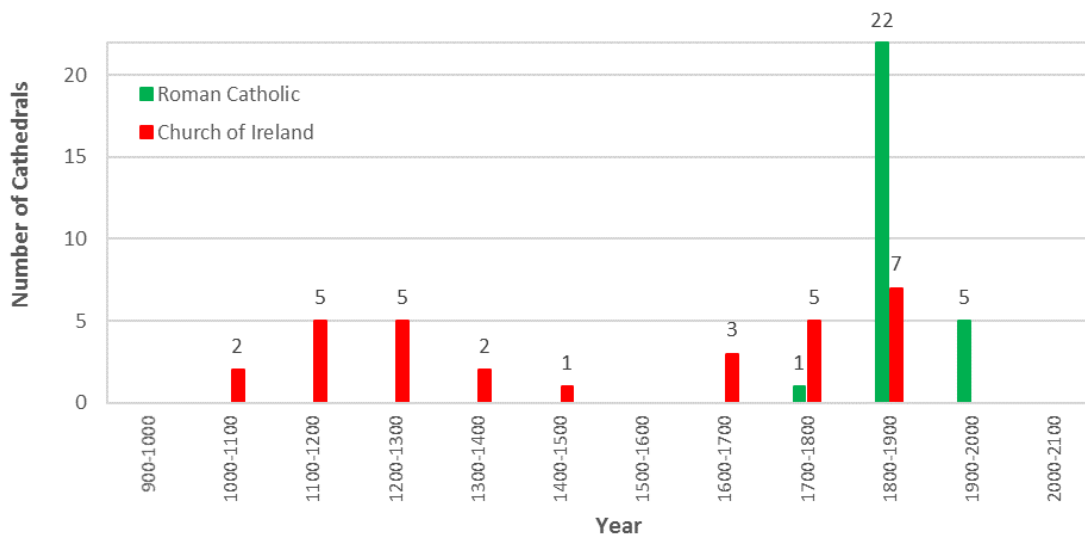

Figure 4.2 - Age profile of cathedrals in Ireland by first consecration date where known

4.2.2 Location

Figure 4.3 shows the locations of the 57 active cathedrals on the island of Ireland and it is noted that they are spread very evenly throughout the country without, of course, any being in the mountainous regions in the extreme West and South West of the country. There is a slight preponderance for cathedrals on or near to the coast which is understandable, as these were the areas where settlers first arrived in the country. Waterford and Dublin are good examples of this being places where the Vikings first landed in Ireland and where they built some of their largest settlements. There are 12 cathedrals in Northern Ireland with 4 being owned by the Roman Catholic

church and 8 owned by the Church of Ireland and 45 cathedrals in the Republic of Ireland with 23 owned by the Roman Catholic church and 22 owned by the Church of Ireland.

By contrast Figure 4.4 shows the locations of the 42 cathedrals owned by the Church of England and it is noted that relatively few of these great buildings are situated on the coast and that may be because, by building them inland, it was possible to better defend them from marauding raiders. However, it would be necessary to carry out a detailed analysis of the age and history of the various English cathedrals to better understand their locations, which is outside the scope of this work.

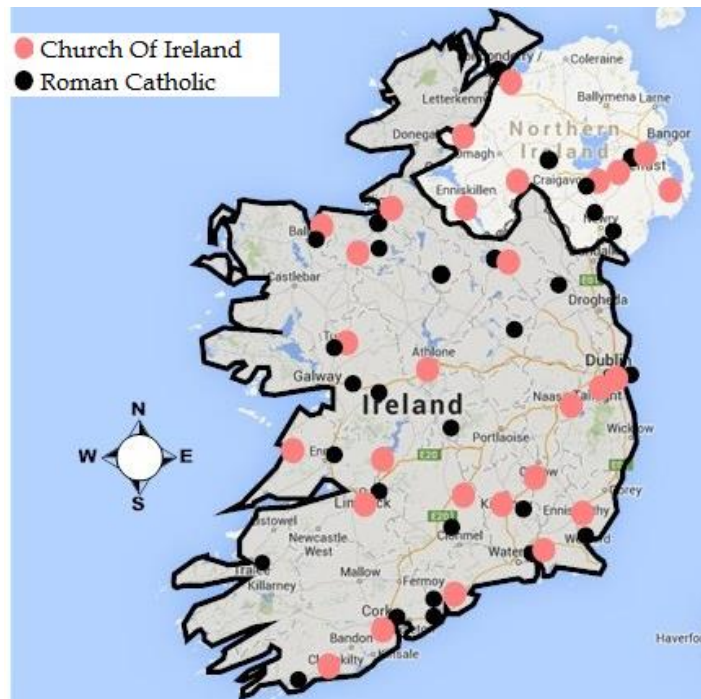

Figure 4.3 - Location of the 57 active cathedrals on the island of Ireland (Google Maps, 2014 for map.)

There are few Irish cathedrals inside what is known as the wider Pale. The Pale, being the area which was under English control, in and around the 14th century, is shown in Figure 4.6. This may have been because when the Roman Catholic church was free to build its own cathedrals, it felt safer building them as far from English control as possible but it is more likely simply to have been a case that RC cathedrals were built in areas which then had the greatest population density. Many towns and cities in Ireland have two cathedrals, one being Roman catholic and one Church of Ireland. Uniquely Dublin actually has three cathedrals two being owned by the Church of Ireland, as explained previously, being Christ Church 'within' and St. Patrick's 'without' the city and the Pro cathedral being Roman Catholic.

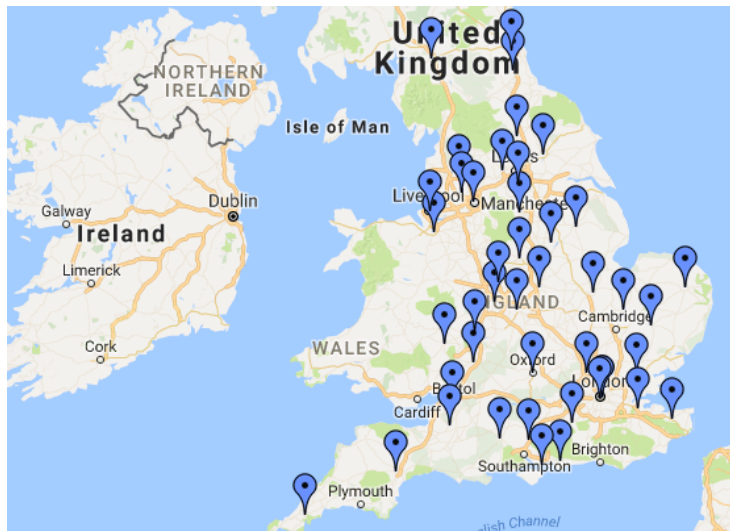

Figure 4.4 - Church of England and the distribution of its 42 cathedrals. (Google Maps, 2014).

The towns and cities with two cathedrals in Ireland are Belfast, Derry/Londonderry, Cork, Limerick, Kilkenny, Waterford, Cavan, Tuam, Sligo and Armagh, the latter being the two most senior cathedrals in the country, being home to the two most senior archbishops those of Armagh, or Primates.

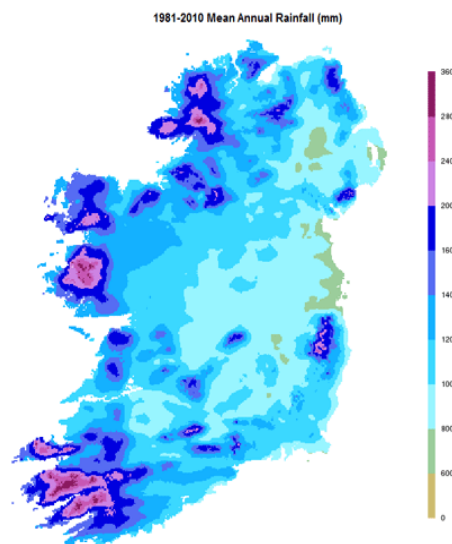

Figure 4.5 - 1981-2010 Mean Annual Rainfall in Ireland (mm). Met Éireann.

The mean annual rainfall map shown in Figure 4.5 shows that the heaviest rain falls in the west of the country and as this area is also most susceptible to wind, driving rain will play a part in the internal environment of the buildings by increasing the amount of moisture entering the buildings.

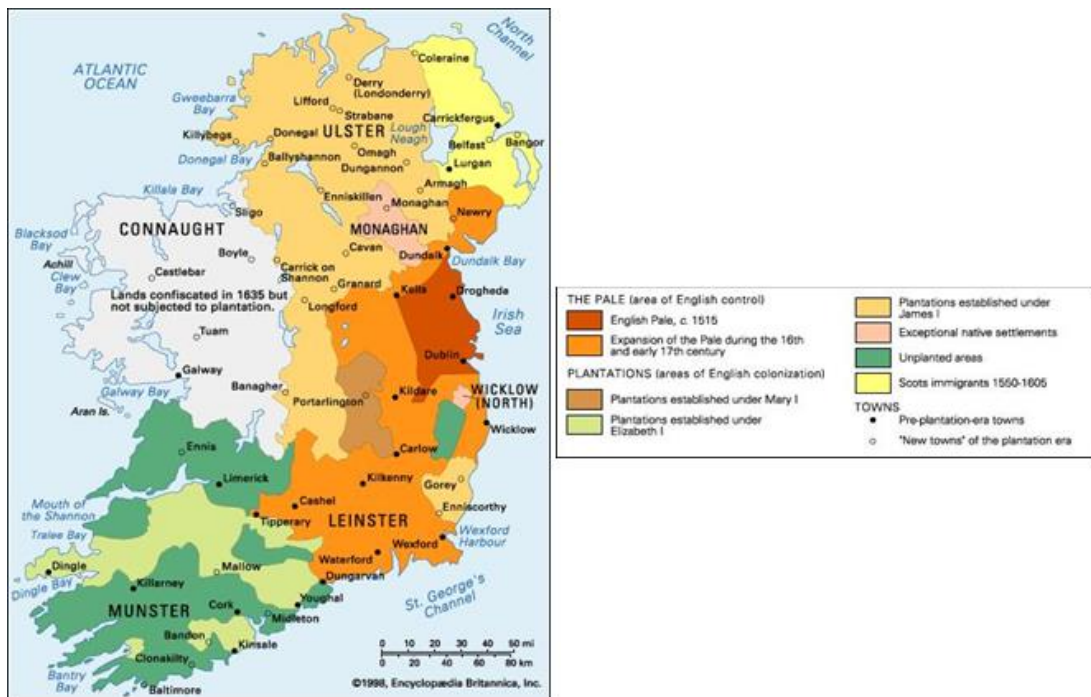

Figure 4.6 - The various plantations into Ireland with dates. Courtesy of Encyclopaedia Britannica Inc. Copyright 1998: used with permission

4.2.3 Size

Size has a direct bearing on the amount of energy used by these cathedrals. The larger the space to be heated, the more energy is required to do so and since most cathedrals in Ireland still heat the building rather than the people in it, this is still relevant today. Chapter 3 explained how the actual internal dimensions of each of the cathedrals were arrived at and, whilst these measurements were approximate, they were consistently established and are adequate for the purposes of categorisation here. It is acknowledged that size is just one of a number of inputs, such as construction, numbers of windows, insulation and so on, which affect the internal thermal environment but it is a logical one to use for the initial categorisation. Some cathedrals had very simple interiors and some were complex with many side chapels and different sized smaller spaces which made them difficult to measure accurately. In particular sloping aisle ceilings and roofs and apsidal East ends of the buildings presented problems for the equipment and time available for taking measurements. Generally, the older cathedrals, which have had many alterations, additions and deletions over the centuries, were the hardest to measure accurately. The cut off for the various sizes may seem arbitrary but roughly coincides with a step down of 10,000m³ in each size category. There is a natural break in the sizes every 10,000m³ in Figure 4.7 and each of these size groups includes a cross section of cathedrals as a whole. Figure 4.7 shows the approximate sizes of the cathedrals in Ireland as well as the split between Roman Catholic and Church of Ireland. The preponderance of small and old cathedrals owned by the minority Church of Ireland is noted.

The graph illustrates the large number of so called small and medium sized cathedrals belonging to the Church of Ireland, when compared to the whole. For instance, of the 24 smallest cathedrals on

the island, 20 belong to the Church of Ireland. The corollary is true in that of the 28 very large, large and medium sized cathedrals, 23 belong to the Roman Catholic church. The reason for this is that when the Roman Catholic church was able and allowed to build its own cathedrals on the easing and repeal of the Penal laws in the 19th century, it built the largest buildings it could afford at the time, remembering that it was catering for the worship of some 98% of the Irish population who were members of that religion. Whilst some of these cathedrals seem large and are so by Irish standards, they are small when compared with many of their European counterparts and a comparison with them has little value.

It can be observed that a number of cathedrals which exist today were actually much larger in the past, such as Christ Church cathedral in Dublin where the whole of the choir was demolished in the 19th century extensive renovations. Size is not relevant in deciding if a church is a cathedral or not, as explained in the Introduction, because in Ireland they range from circa 44,000m³ in the case of Galway to circa 1,060m³ in the case of Kilfenora. As O'Keefe (2015) points out, the small size of Irish cathedrals tends to imply that they were not equipped to deal with the complex religious rituals which one would expect a mother church of a diocese to be able to stage. It is likely that these elaborate events were not yet acceptable to the clergy in Ireland.

It can be concluded therefore that size is just one of a number of components which affect the internal thermal environment of the cathedrals. All cathedrals enclose large, open undivided spaces which makes the buildings difficult to heat quickly. The rate that they do heat up, and the amount of energy required to do so, is directly proportional to the size.

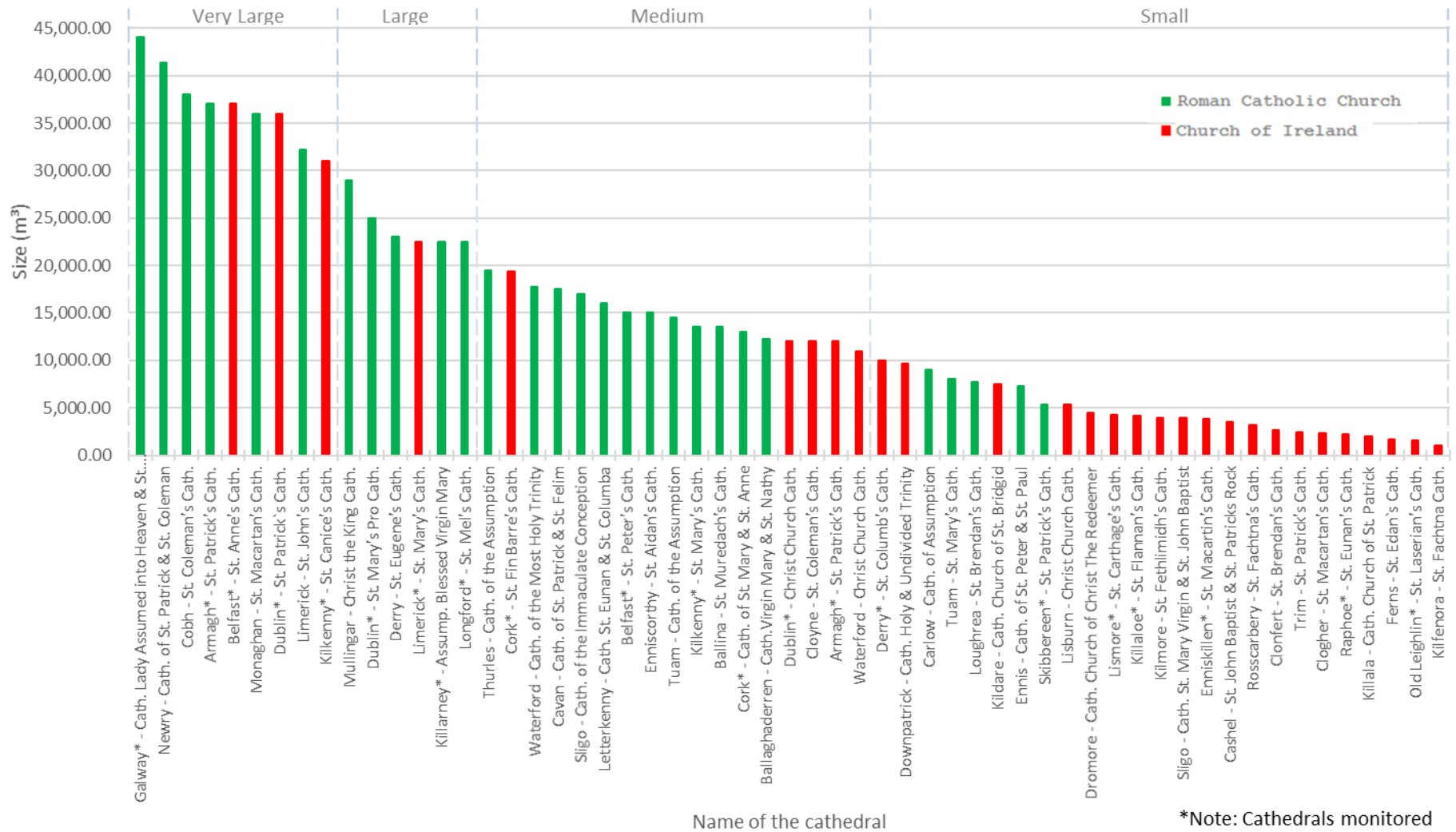

Figure 4.7 - Classification of Irish Cathedrals by size. All sizes are approximate

4.2.4 Construction

Constructing a major ecclesiastical building takes many skills and trades and considerable time and money. Stained glass windows are present in all Irish cathedrals and are from various artists and from different ages. Some of the oldest cathedrals with the oldest stained glass, such as Lismore and Kildare are particular examples where recent large changes in internal temperature (T) and Relative Humidity (RH) occur and which may therefore result in premature aging of the stained glass. St. Patrick's and Christ Church cathedrals in Dublin, as will be explained in Chapter 5, maintain a high and constant ambient T which is good for the windows preservation and the fabric in general but not many cathedrals can afford to do this. With regard to the floors in Irish cathedrals, the oldest cathedrals might well have had no artificial floors when they were built and would have just been bare earth. These days all cathedrals have floors with a variety of coverings and most likely without any insulation underneath. The type of floor covering will have an impact on the internal environment within the cathedral as some floor coverings, such as carpet and timber absorb heat and some, such as tiles, reflect heat. Some cathedrals have areas which were carpeted but no large cathedrals are carpeted throughout. It is common in Irish cathedrals, as may well be the case elsewhere, to have wooden floors under the pews and this may well be to protect fine floors or may be because the wood holds the heat better. A number of cathedrals are tiled throughout and some, such as St. Mary's Church of Ireland cathedral in Limerick, are covered in large flag stones.

The walls of all cathedrals are solid stone on the outside and inside, with rubble infill, some with rendering on the inside and outside and some with none. In some cases, such as in St. Columb's in Derry, the internal rendering has been removed in recent years for aesthetic reasons but also to prevent interstitial condensation in the walls. To calculate accurately the U value or rate of heat loss of rubble filled walls it would be necessary to know the different stones which make up the rubble since each type of stone has a different U value. In Newry cathedral, for example, the internal walls are completely covered in mosaics which will help to reflect and contain heat within the building although it was almost certainly installed for aesthetic reasons and not to save heat. At the time cathedrals were built fossil fuels were cheap and conservation and preservation not matters of particular interest. The thickness and type of walls have a large influence on the thermal mass of the building and hence on the internal thermal environment. It is often considered that thermal mass must be a good thing but as Reilly and Kinnane (2016) point out, this may not be the case when the heating is intermittent, as is the case in most Irish cathedrals. The graphs at the end of Chapter 5 show the profile for intermittently heated cathedrals and the wasted heat which can result, such as in St. Canice's and in Armagh.

The roofs in most Irish cathedrals, having been replaced many times over the centuries, are almost exclusively of slate, with the exception of Limerick RC cathedral which is copper. The ceilings, where

they are separate from the roof, are usually plastered, sometimes flat and sometimes ornately painted, such as that in Armagh RC cathedral as shown in Figure 4.8. Some ceilings are of stone as in St. Patrick's cathedral, Dublin. In most cases it appears that ceilings are not insulated although most cathedral managers did not know if there were or not. Known examples where ceiling insulation is installed are in St. Mel's in Longford and in Galway cathedral and the influence this has on internal temperature is discussed in Chapter 5.



Figure 4.8 - Armagh Roman Catholic cathedral showing part of the painted ceiling

The void between the ceiling and the roof can be as much as 20% of the height of the building and this space can hold a lot of heat even in the absence of insulation. It is difficult to discern even with an FLIR camera, if there is insulation in this area without a visual inspection. A weakness of the research was that visual inspections were often not possible either for health and safety reasons or because the people being interviewed did not know how to access these areas of the building.

Christian churches and cathedrals were built with the function of holding religious services. This means that they tend to follow a recognised pattern in locating the altar, which is the most sacred part of the cathedral, at the East end and the nave, where the people gathered, at the West end. Originally the two parts of the cathedral were separated by a screen in order to keep an element of mystery about what went on behind the screen. The choir was also separated from the nave by the same screen. Today screens tend to be used to separate used parts of the cathedral from those parts which are not used, such as in Old Leighlin, Lismore and Cloyne. This is a purely Church of Ireland phenomena and is not in use in the Roman Catholic church. After Vatican II or the Second Vatican Council, 1962-1965, Roman Catholic cathedrals were required to reorder the sanctuaries of the cathedrals to ensure that the officiating clergy were always facing the congregation. This usually required that the altar was brought forward from the East wall of the cathedral and moved into the

nave. An example of this is shown in Figure 4.9 where the altar in Armagh RC cathedral has been moved forward, a substantial distance, from the East wall.



Figure 4.9 - Armagh Roman Catholic cathedral, after Vatican II showing the altar, which has been moved from the East wall further into the nave

In some cases a screen was then built to separate the rear of the sanctuary from the East wall of the cathedral to create an ambulatory and Armagh RC cathedral is a good example of where this has been done.

St. Mel's cathedral in Longford is another example of where the altar has been moved forwards a considerable distance from the East wall, as shown in Figure 4.10. They too have built a small screen at the rear of the sanctuary but it is not there to create an ambulatory but just to separate the East wall from the sanctuary. The East wall in the case of St. Mel's is quite plain because they were able to incorporate the requirements of Vatican II when rebuilding the cathedral.



Figure 4.10 - St. Mel's cathedral and the position of the altar, which is some distance from the East wall

Many Irish cathedrals are built on the site of previous buildings and, in particular, monastic ones and so may not have had complete freedom with regard to the site plan and layout. Many of the oldest, such as Christ Church and St. Patrick's in Dublin, Old Leighlin and Lismore have been substantially altered over the years. Not all Irish cathedrals were able to follow the unofficial Christian tradition of the building running East to West and, in the case of Enniscorthy cathedral, the building is orientated North to South due to the site of the cathedral which is on the side of a hill. Thurles is another Irish cathedral which is orientated North to South but the reason for this is unclear unless perhaps the road outside the cathedral was in place, in some form, before the cathedral and the cathedral was orientated accordingly. Various suggestions have been put forward over the years as to why most Christian churches have the Apse or altar area in the East of the buildings and the buildings therefore are orientated to face East. Most Christian basilicas in and around Rome are orientated West to East which may have been because the Emperor Constantine was known to also worship the sun, which of course rises in the East.

This is not to say that all Irish cathedrals were built during these times but most tended to copy these styles, with notable exceptions, such as the basilica like, Mullingar Roman Catholic cathedral. The one easily recognised feature of the Gothic era is the pointed arch which was probably a Moorish feature copied by the Christians. Compare, for instance, Figure 4.11 which is a window, with a pointed arch, in the main Mosque in Muscat in Oman with Figure 4.12 which shows a stained glass window in Armagh Roman Catholic Cathedral, with its pointed arch.

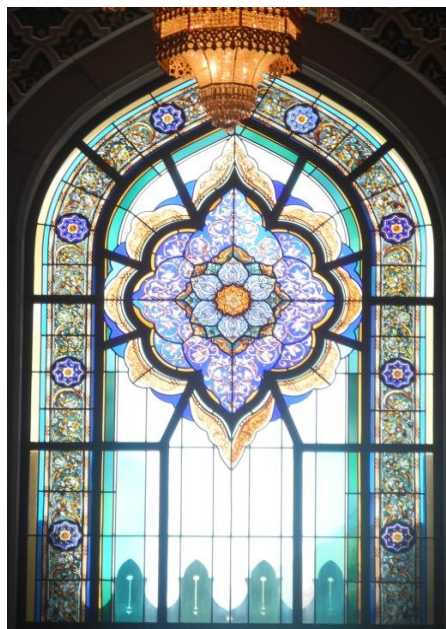

Figure 4.11 - Main Mosque, Muscat, Oman

Images of living things cannot be displayed in Mosques and so the look of a stained glass window in a mosque is often quite different to that found in a Christian church or cathedral as Figure 4.12 from Armagh cathedral shows.

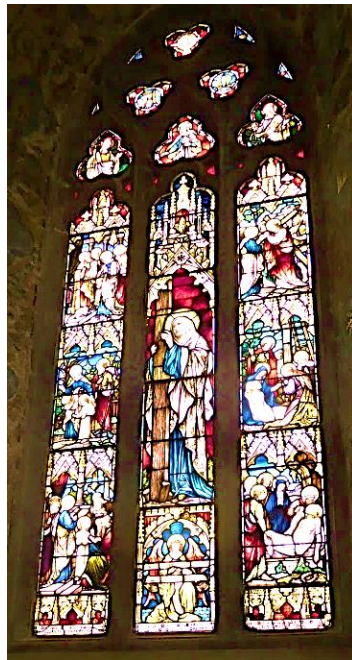

Figure 4.12 - A stained glass window in the Decorated Gothic cathedral of Armagh

Whilst a number of architectural styles can be observed in Irish cathedrals, as O’Keefe (2015) points out, the architects of Irish cathedrals tended to be followers rather than innovators or creators of architectural styles. Since many of the master masons and the people who built the Irish cathedrals came from England, and sometimes even France, it is not surprising that they built in a style which was familiar to them. Some examples are Armagh Roman Catholic cathedral and Cobh Roman Catholic cathedral which are both Gothic Revival as shown in Figure 4.13 and Figure 4.14 respectively. This style was characterised by steeply sloping roofs, ornate and decorated features and often clover shaped windows.



Figure 4.13 - Armagh (Roman Catholic) Cathedral



Figure 4.14 - Cobh Cathedral

An example of Romanesque Revival style can be found in Sligo (RC) Cathedral as shown in Figure 4.15. Features of this style include rounded arches and, in the case of religious buildings, often just one tower.



Figure 4.15 - Cathedral of The Immaculate Conception, Sligo. (Photo: Sligo parish)

The Church of Ireland cathedral in Sligo in Figure 4.16 is an example of what might appear to be Romanesque with Gothic additions but is in fact an 18th century building. Interestingly, Galloway (1992) states that the architect of this cathedral was a man called Richard Cassels who designed a number of country houses in Ireland including Leinster House where the Irish parliament sits, but he also designed the Printing House and Dining Hall in Trinity College Dublin.



Figure 4.16 - The cathedral Church of St. Mary and St. John the Baptist (CI), Sligo (Photo: Kind permission of the Dean and Chapter)

St. Fin Barre's cathedral in Cork is a mixture of Romanesque and Gothic and whilst it was not, apparently, universally liked when built, it is a striking building as can be seen in Figure 4.17.



Figure 4.17 - St. Fin Barre's cathedral, Cork

St. Patrick's, cathedral in Dublin, which is the National Cathedral of The Church of Ireland, has, like all of the older cathedrals, been altered many times since it was first built sometime in the early 13th century, and is another example of a Gothic cathedral with its distinctly pointed arch windows, as seen in Figure 4.18. The choir school, which is Ireland's oldest school (founded, 1432) and the Deanery are separate buildings on the far side of the cathedral and were not included in the monitoring of the cathedral. St. Patrick's web site claims that the cathedral is the tallest in Ireland,

which may well be the case, but considering it is built on marshy ground, it must have been a considerable engineering challenge to support the tower.



Figure 4.18 - St. Patrick's cathedral, Dublin. Photograph: Patrick Donald

In contrast, the cathedral Church of Christ The King in Mullingar is more like a Roman basilica than a cathedral and is very unlike other Irish cathedrals as can be seen in Figure 4.19. Mullingar cathedral is very large by Irish standards and has a large internal capacity with seating for some 1,800 people. Ecclesiastical basilica are split between major basilica, all four of which are in Rome and minor basilica, which receive certain privileges from Rome and are found in other countries. Basilica are often pilgrimage sites and are notable by being rectangular and having colonnades inside and porticos on the outside.



Figure 4.19 - Mullingar cathedral. (Photo: Mullingar parish)

Derry cathedral or St. Columb's Church of Ireland cathedral (Figure 4.20), which was built on the walls of Derry/Londonderry, is an example of what is called Ulster Gothic, or Planter's Gothic and sometimes called Gothic Revival. It is a cathedral with a colourful and dramatic history over the

centuries and was damaged a number of times during the 1970s by bombs. However it has survived, in spite of being situated next door to the city court house and has a thriving congregation.



Figure 4.20 - St. Columb's cathedral, Derry. (Photo, courtesy of Curious Ireland Ltd.)

Many Irish cathedrals contain outstanding features, such as in Newry cathedral in Figure 4.20 with its ceramics which cover nearly all of the internal walls. Having walls covered in ceramics will have a direct effect on the internal thermal environment in the cathedral as the walls will tend to radiate back into the building more of the heat than a plastered wall would.



Figure 4.21 - Newry Cathedral. On the left hand side it is possible to see the outside of the cathedral and on the right hand side, the interior of the building with its mosaics on the walls

Irish cathedrals by their nature are massive, with thick walls and large thermal mass. Windows, often stained glass, usually single glazed. Roofs and floors are largely uninsulated. Doors are often leaking and left open all day. This set of parameters defines many of the heating characteristics discussed in Chapter 5.

4.2.5 Artefacts

A survey of all the relics in Irish cathedrals was not undertaken as it was beyond the scope of this research but the internal thermal environment can have an adverse and positive effect on such items. Artefacts are few in Irish cathedrals since the English King Henry VIII broke with the church in Rome in 1533 and disbanded over 800 monasteries in England and Ireland, taking their treasurers

and land for the Treasury. Most Irish relics and artefacts were lost at that time however a number of Irish cathedrals, such as Enniskillen, Belfast St. Anne's, St. Patrick's in Dublin and Derry St. Columb's, contain flags which are of intrinsic value and these would be significantly damaged by inappropriate levels of T and RH. (Camuffo, 2014). The European Committee for Standardisation (CEN) in 2003 produced standards for cultural heritage but without allocating specific figures to individual hygroscopic materials. Rather they looked at the historic environment in which the artefact was kept. The committee produced a standard EN15757: 2010 'Conservation of Cultural Property – Specifications for temperature and relative humidity to limit climate-induced mechanical damage in organic hygroscopic materials'. (Camuffo, 2014). Flags are hygroscopic materials which absorb humidity and are very susceptible to sudden changes in their environment. Armagh Roman catholic cathedral has two Cardinal's hats from deceased cardinals hanging from the roof. The idea is that when they decay and fall they will represent the decay and death of the human body. Such hats are apparently no longer given to cardinals (Cathedral Guide Book, 2003). During the site visits no evidence was provided or seen of the importance of protecting artefacts from changes in their environment.

There are a number of religious relics still in Irish cathedrals but they tend to be small in number. For instance Christ Church cathedral in Dublin had, supposedly, the heart of St. Laurence O'Toole in a brass case attached to the wall in the Lady Chapel. Unfortunately, in March 2012 it was stolen and not recovered. Christ Church cathedral also has a treasury exhibition in the crypt but the exhibits in it are all in environmentally controlled glass cases. St. Patrick's cathedral in Dublin has many artefacts including flags, historic wooden doors and monuments, as well as some of the finest monuments in Ireland. Derry cathedral has a number of flags dating from the time of the famous siege and St. Anne's cathedral has many old military flags. All cathedrals have fine altar cloths, some of which are old and very ornate. They are prone to damage from the internal thermal and moisture environment of the cathedral. Roman Catholic cathedrals have some relics and items such as Holy oils often set in elaborate glass cases.

Books have already been mentioned and they are perhaps the most easily damaged by inappropriate heating since they are highly hygroscopic. Only Lismore cathedral and, to a lesser extent, Killaloe cathedral are known to have libraries, in the case of Killaloe above the nave or attached to the nave as in the case of Lismore. Many of the books which are in daily use by the clergy are also of intrinsic and monetary value and should be protected from inappropriate levels of temperature and relative humidity.

One artefact which most cathedrals do contain however is a pipe organ and the details of these, where known, are shown in Table 4.1. Where details were not available during the site visits then the details for this table have been acquired from the cathedral web sites which are listed in the

References. Pipe organs are made using a number of different components which can be wood, of various kinds, plastic, leather, steel and brass. Each of these will react in different ways and at different speeds to changes in the internal environment in the cathedral. Further details of potential damage to these instruments caused by inappropriate heating can be found in Chapter 2. A few smaller cathedrals have found the cost of maintaining a pipe organ to be too high and have switched to an electric organ.

Table 4.1 - List of Irish cathedral pipe organs, where it was possible to obtain the information.

City/Town	Name of cathedral	Organ maker and organ age
Galway	Our Lady Assumed into Heaven and St. Nicholas (RC)	Rushworth and Dreaper, Liverpool, 1966. Trevor Crowe, 2006-2007.
Newry	St. Patrick and St. Coleman (RC)	Installed in 1891.
Cobh	St. Coleman's (RC)	Telford and Telford, 1905. Presently being rebuilt by Frateli Ruffatti, Padua.
Armagh	St. Patrick's (RC)	William Telford 1873/74. Rebuilt by the Irish Organ Company, 1987/89.
Belfast	St. Anne's (CI)	Harrison and Harrison, Durham. 1907. Rebuilt 1970.
Dublin	St. Patrick's (CI)	First organ 1471. Henry Willis & Sons, 1902. rebuilt 1963, J. Walker & Sons.
Monaghan	St. Macartan's (RC)	Telford and Telford, Dublin William Hill & Son, England, 1864. restored 1960's by Henry Willis & Son.
Limerick	St. John's (RC)	Kenneth Jones, 1982. Stephen Adams, Carlow, 2005.
Kilkenny	St. Canice's (CI)	Bevington, London, 1854. Rebuilt Trevor Crowe., 2005.
Mullingar	Christ The King (RC)	Unknown.
Dublin	Pro cathedral (RC)	William Hill, 1908. J. Walker & Sons, 1971.
Derry	St. Eugene's (RC)	Messrs. Telford & Co., Dublin.
Limerick	St. Mary's (CI)	Telford & Telford 1924.
Killarney	Assumption of The Blessed Virgin Mary (RC)	William Telford & Son, 1869. Telford & Telford, 1938. Irish Organ Company, 1973.
Longford	St. Mel's (RC)	Fratelli Ruffatti, Padua, 2014.
Thurles	Cathedral of The Assumption (RC)	Unknown. First mention 1633. William Hill, London, 1870.
Cork	St. Fin Barre's (CI)	T.W. Megahy 1889 (below floor level). J.W. Walker & Sons, London, 1965. Trevor Crowe, 2011 - 2013.
Waterford	Most Holy Trinity (RC)	William Hill & Son, 1858. William Hill & Son, 1901. Irish Organ Company, 1964.
Cavan	St. Patrick & St. Phelim (RC)	Unknown.
Sligo	Immaculate Conception (RC)	Unknown.
Letterkenny	St. Eunan & St. Columba (RC)	Unknown.
Belfast	St. Peter's (RC)	Kenneth Jones, Bray. 2005. Original by B. Pels & Zoon, Holland.

Enniscorthy	St. Aidan's (RC)	John White & Son, Dublin. 1894, Telford & Telford, Dublin. Irish Organ Company 1982.
Tuam	Cathedral of the Assumption (RC)	John Compton, 1936. Irish Organ Company, 1999. Trevor Crowe., 2017.
Kilkenny	St. Mary's RC cathedral (RC)	First organ installed in 1866, 1928 major restoration.
Ballina	St. Muredach's (RC)	Unknown
Cork	St. Mary's (RC)	Unknown
Ballaghadereen	Annunciation & St. Nathy (RC)	Unknown.
Armagh	St. Patrick's (CI)	J.W.Walker & Sons Ltd., 1840, with alterations up to 1978. Wells-Kennedy partnership Ltd., 1989 and 1996.
Cloyne	St. Coleman's (CI)	
Dublin	Christ Church (CI)	Kenneth Jones & Associates, 1984. Flentrop Orgelbouw, 2004.
Waterford	Christ Church (CI)	Unknown.
Derry	St. Columb's (CI)	New organ 2016.
Downpatrick	Holy Trinity (CI)	Original by Samuel Green. Harrison and Harrison, Durham, 1913/1914. Current appeal for rebuild.
Carlow	Cathedral of the Assumption (RC)	Bevington, 1850. William Hill, 1940. Rebuild just completed.
Tuam	St. Mary's (CI)	Unknown.
Loughrea	St. Brendan's (RC)	Evan's & Barr (no date). Telford & Telford, 1906.
Kildare	St. Briget's (CI)	Conacher, 1898.
Ennis	St. Peter & St. Paul (RC)	Evans & Barr, 1930.
Skibereen	St. Patrick (RC)	White (1850). Restored 2007, Neiland & Creane.
Lisburn	Christ Church (CI)	Unknown.
Dromore	Christ The Redeemer (CI)	Trevor Crowe, 2009.
Lismore	St. Carthage's (CI)	Unknown.
Killaloe	St. Flannan's (CI)	1782. Nicholas & Lord, Walsall, 1900. Major work 1966 and 2002.
Kilmore/Cavan	St. St. Fethlimidh's (CI)	Unknown.
Sligo	St. Mary & St. John (CI)	Unknown.
Enniskillen	St. Macartin's (CI)	Unknown.
Cashel	St. John & St. Patrick (CI)	Unknown.
Rosscarbery	St. Fachtna's (CI)	Unknown.
Clonfert	St. Brendan's (CI)	Unknown.
Trim	St. Patrick's (CI)	Unknown.
Clogher	St. Macartan's (CI)	Unknown.
Raphoe	St. Eunan's (CI)	Wells Kennedy Partnership, 1997.
Killala	St. Patrick's (CI)	Unknown.
Ferns	St. Edan's (CI)	Unknown.
Old leighlin	St. Lasarian's (CI)	Unknown.
Kilfenora	St. Fachtna's (CI)	None

4.2.6 Shops and Coffee Shops

It was observed that 12 cathedrals had shops either in the nave (in the crypt under the nave in the case of Christ Church cathedral in Dublin) or in areas off the nave. A number of cathedrals had shops attached to the diocesan offices which may have been some distance from the cathedral and these are not included in this analysis. A good example of where a shop is close to but not connected to a cathedral is the Roman Catholic cathedral in Carlow where the cathedral and diocesan offices are only about 100 meters from the cathedral and are in effect on the same site. As part of the office complex there is a large shop.

The cathedrals St. Nicholas in Galway, St. Anne's in Belfast, St. Patrick's, Dublin and Armagh RC and CI, St. Canice's (Kilkenny), Christ the King in Mullingar, St. Fin Barre's in Cork, Christ Church (Dublin), St. Columb's (Derry) and St. Patrick's in Down had shops installed in the building.

There is no reason why the presence of these shops, per se, should affect the internal environment of the cathedral unless they result in larger numbers of people visiting and lingering in the cathedral. In the case of St. Canice's and St. Fin Barre's the shops are part of the area where people pay, as tourists, to enter the cathedral. A number of other cathedrals have simple tables where booklets and post cards are displayed and people are asked to put money into a box, if they take an item. These are not included in any figures as they would have no effect on the internal environment in the relevant cathedrals.

There is a marked difference between what is sold in Roman Catholic cathedrals, which are exclusively items of a religious nature, and Church of Ireland cathedrals, which sell religious items but also items of a more touristic nature.

Three cathedrals were observed to have coffee shops either in the cathedral or beneath it. Areas which sell hot drinks could have an effect on the internal environment in the cathedral as a result of steam and condensation but, with the exception of Kilkenny described presently, the numbers of hot drinks sold would be most unlikely to adversely or otherwise affect the internal thermal environment in the cathedral. In the case of St. Patrick's cathedral in Dublin, coffee was being served in the nave of the cathedral but the building is so large that any affects from this would probably have been negligible. Further research is needed to establish if having these facilities inside the cathedrals has any effect on the internal thermal environment. In the case of Lisburn cathedral they have actually turned the whole West end of the nave into a coffee shop which is open to the public from Tuesday to Saturdays. However, they have built a glass screen, which covers the area from floor to ceiling, between the shop and the remainder of the nave and so it is unlikely that the coffee shop will significantly affect the internal environment in the cathedral. Kilkenny Roman Catholic cathedral has built a large and obviously successful coffee shop beneath the East end of the cathedral which has

been possible due to the fact that the cathedral is built on the side of a hill. The cathedral is situated just off the city's main street which makes this a popular venue for snacks and lunch.

It is supposed that these facilities are provided for two reasons namely, to provide extra revenue and to provide a service for those using the cathedrals. Further research would be required to see how, if at all, these facilities impact on the internal thermal environment in the main part of the cathedrals.

4.3.1 Usage

The primary function of these buildings always was and still is the holding of religious services and this applies to both traditions. It is one of the things which make cathedrals unique in that they are still used for the purpose for which they were built even though most are hundreds of years old. Section 4.3.3, which discusses the number of religious services held in the various cathedrals, shows that, generally, more services are held in Roman Catholic cathedrals than in Church of Ireland cathedrals. This is because each RC cathedral holds Mass at least once per day and more often at weekends whereas many CI cathedrals, particularly the smaller ones, only hold services on Sundays. In addition, all RC cathedrals hold a Mass on Saturday evenings which CI cathedrals do not. There is a tradition in RC cathedrals of people calling in for short periods of personal reflection and prayer at any time during the day and this is not so prevalent in CI cathedrals, even when they are open daily. This may simply be because the number of Church of Ireland members, especially in the Republic of Ireland, is so small.

There is one clear distinction between the way in which Church of Ireland cathedrals are used and the way in which Roman Catholic cathedrals are used. CI cathedrals, generally for financial reasons, hold many events which would not be considered strictly liturgical and in many cases cathedrals can be hired for concerts and also for dinners. Other events held in some CI cathedrals include college graduation ceremonies, recitals and wedding receptions. The web site of St. Patrick's cathedral in Dublin for the month of July 2017, includes, as well as the daily regular services, family workshop days which include flag making, drawing, 'hanging sculptures' and items about Gulliver's Travels. The author, Jonathan Swift, was a Dean of the cathedral from 1713 until 1745. (St. Patrick's cathedral, 2017)). Christ Church cathedral in Dublin has hosted secular dinners in both the nave and crypt for a number of different clients who have no connection to the cathedral. Some major films have also been filmed in Christ Church cathedral such as the TV series 'The Tudors'. St. Canice's (CI) cathedral in Kilkenny plays host to an annual music festival each year. Various commercial orchestras play and record concerts in the larger CI cathedrals, including the orchestra of the State broadcasting company, namely RTE. These are just some examples of events which are held in CI cathedral. Such events are at the discretion of the various deans and chapters but do undoubtedly help with the cathedral finances. Such events increase the energy requirements and, where people have paid for tickets to events, they expect a certain level of thermal comfort. Since many events are evening

events and the heating is required to be either switched on or kept on for them, this can change the internal thermal environment in the building and may result in quite large changes in both T and RH.

CI cathedrals which attract tourists tend to be open all day, but many are only open for services. RC cathedrals are universally open all day and every day for both private and organised worship. Halls are often attached to cathedrals either directly or very close by and these are used for a variety of purposes, but they are not included in this research.

Roman Catholic cathedrals and churches are specifically precluded, by the Vatican, from holding non-religious events inside the buildings.

Usage is the biggest difference between the two traditions and has one of the largest impacts on costs and heating. Roman Catholic cathedral can only be used for religious services whilst Church of Ireland cathedrals have much more leeway regarding the uses to which the buildings can be put. The debate concerning the merits, or otherwise, of these various policies are beyond the scope of this thesis.

4.3.2 Opening Hours

CI cathedrals, or at least those which are not major tourist attractions, tend to only be open on Sundays. Some which attract tourists in the summer, do open daily in the summer months and Kildare is an example of this. A few CI cathedrals are major tourist attractions throughout the year and are open every day. including St. Patrick's and Christ Church cathedrals in Dublin, St. Canice's in Kilkenny, St. Fin Barre's in Cork and Lismore cathedral. Kildare and Kilkenny have ancient round towers in the grounds which help to generate tourist income.

A number of CI cathedrals charge tourists for entry to the buildings but not for entry to most religious services. People are charged for some services such as carol services at Christmas in some cathedrals.

All RC cathedrals are open every day and all day (which is usually from 0800 until 1800) but some are open earlier and stay open longer depending on the services which they offer. RC cathedrals which happen to be in major tourist towns, such as Killarney, will also receive tourist visitors but they do not charge for entry since, as has already been pointed out, it is a tradition of the RC church for people to call in for personal devotions at any time of the day. Opening hours are extended, in both traditions, during the Christian festivals of Easter and Christmas.

Opening hours are another major difference between the two traditions although even though RC cathedrals are open all day and every day, they usually do not heat the buildings except for services. However, as they have services daily the heat is on daily, which is unlike most Church of Ireland cathedrals. The large Church of Ireland cathedral which are open daily and which have services daily

do also have the heating on sometimes not just for the services but also all day, such as St. Patrick's cathedral in Dublin.

4.3.3 Numbers of Services Each Year

The yearly number of services held in the cathedrals could only be estimated due to the fact that extra services are held each year on such major religious festivals as Christmas and Easter. Furthermore, because cathedrals host irregular events such as funerals and weddings, exact numbers cannot be given. The data for the estimated number of services held each year as derived from the questionnaire are shown in Table 4.2.

Table 4.2 - Estimated number of services per year in each of the 57 Irish cathedrals

ROMAN CATHOLIC CHURCH			CHURCH OF IRELAND		
Town / City	Name of the Cathedral	Number of Services	Town / City	Name of the Cathedral	Number of Services
Armagh	St. Patrick's cathedral	520	Armagh	St. Patrick's cathedral	780
Ballaghaderren	Cath. of the Anunciation of the Blessed Virgin Mary & St. Nathy	832	Belfast	St. Ann's cathedral	1,040
Ballina	St. Muredach's cathedral	780	Cashel	St. John the Baptist and St. Patricks Rock	364
Belfast	St. Peter's cathedral	416	Cavan/Kilmore	St. Fethlimidh's cathedral	104
Carlow	Cathedral of Assumption	780	Clogher	St. Macartan`s cathedral	104
Cavan	Cathedral of St. Patrick and St. Felim	416	Clonfert	St. Brendan`s cathedral	4
Cobh	St. Coleman's cathedral	800	Cloyne	St. Coleman's cathedral	52
Cork	Cathedral of St. Mary and St. Anne	416	Cork	St. Fin Barre's cathedral	676
Dublin	St. Mary's Pro Cathedral	1,560	Downpatrick	Down cathedral Holy and undivided Trinity	156
Ennis	Cathedral of St. Peter & St. Paul	416	Dromore	The Cathedral Church of Christ The Redeemer	208
Enniscorthy	St. Aidan's cathedral	260	Dublin	St. Patrick`s cathedral	988
Galway	Cathedral of Our Lady Assumed into Heaven and St. Nicholas	1,144	Dublin	Christ Church cathedral	1,092
Kilkenny	St. Mary's cathedral	260	Enniskillen	St. Macartin`s cathedral	156
Killarney	Assumption of the Blessed Virgin Mary	728	Ferns	St. Edan`s cathedral	52
Letterkenny	Cathedral of St. Eunan and St. Columba	1,248	Kildare	The Cathedral Church of St. Brigid	52
Limerick	St. John's cathedral	832	Kilfenora	St. Fachtna	3
Londonderry/Derry	St. Eugene's cathedral	1,196	Kilkenny	St. Canice`s cathedral	156
Longford	St. Mel's	468	Killala	Cathedral Church of St. Patrick	24
Loughrea	St. Brendan's	728	Killaloe	St. Flannan's Cathedral	52
Monaghan	St. Macartan's cathedral	156	Limerick	St. Mary's Cathedral	416
Mullingar	Christ the King cathedral	832	Lisburn	Christ Church Cathedral	156

ROMAN CATHOLIC CHURCH			CHURCH OF IRELAND		
Town / City	Name of the Cathedral	Number of Services	Town / City	Name of the Cathedral	Number of Services
Newry	Cathedral of St. Patrick and St. Coleman	832	Lismore	St. Carthage's Cathedral	156
Skibereen	St. Patrick's cathedral	416	Londonderry/Derry	St. Columb's Cathedral	208
Sligo	Cathedral of the Immaculate Conception	416	Old Leighlin	St. Laserian's Cathedral	52
Thurles	Cathedral of the Assumption	780	Raphoe	St. Eunan's Cathedral	104
Tuam	Cathedral of the Assumption	520	Rosscarbery	St. Fachtna's cathedral	364
Waterford	Cathedral of the Most Holy Trinity	780	Sligo	Cathedral of St. Mary the Virgin and St. John the Baptist	52
			Trim	St. Patrick's Cathedral	52
			Tuam	St. Mary's cathedral	52
			Waterford	Christ Church Cathedral	156

The daily reading of prayers which happens in some cathedrals was not included in this data. The data for the numbers was obtained from the questionnaire, from notice boards situated at the entrance to the cathedrals or from cathedral publications, but primarily from the cathedral web sites whose addresses are listed in the References. An example of a cathedral notice board is shown in Figure 4.22.



Figure 4.22 - A notice board at the entrance to a cathedral (Armagh RC) showing Mass times

The number of services tend to reflect the size of the congregation being served by a particular cathedral rather than any reflection on the size of the building itself. For instance, some quite large CI cathedrals, such as Lismore and Kildare, no longer have a congregation of sufficient size to justify the same number of services which they used to hold. Shifting demographics have resulted in changes to the number of services being held in a number of cathedrals. The Central Statistics Office in Ireland recently recorded that the number of people in the Republic of Ireland who said that they had no religion had gone up by 73.6% from 269,800 to 468,400 between 2011 and 2016 (BBC, 06.04.2017). This may have an effect on the demand for services which are held in cathedrals. The statistics also show a major movement of population from regional towns to Dublin, which will have an effect on

those cathedrals situated in more rural areas. The data shows an average number of services in RC cathedrals of 686 and for CI cathedrals of 261 and this reflects the fact that RC cathedrals hold daily services and a service on Saturday evenings whilst most CI cathedrals only hold services on Sundays.

4.3.4 Numbers Attending

It was not possible to establish with accuracy the numbers of people who attend religious services in Irish cathedrals. This is because Roman Catholic cathedrals do not keep records of the numbers attending services. CI cathedrals do keep a record of weekly attendances but access to these records was seldom possible for confidentiality reasons. Whilst access to such records would be useful it is perhaps the trends which these numbers would show which would be most useful. In terms of future energy needs, for instance, if it could be shown that numbers attending Saturday evening Mass were growing and those attending Sunday morning Mass were falling, then the heating could be adjusted to allow for this. The Church of Ireland did carry out a survey of attendances at the regular Sunday morning services in all churches, including cathedrals, for five weeks in January 2017. At the time of writing this thesis, the data from this survey was not available. Where sacristans and sextons were prepared to estimate the numbers attending services each year, they are given in Table 4.3. What would be more useful would be the figures for occupancy vs volume or how many people attend services and at what time and on what days. This data is not available and is a major omission on the part of the churches since realistic long and medium-term planning is not possible without these figures.

Table 4.3 – Estimated number of people attending specific Irish cathedrals per year

City	Cathedral	Number of attendees (approx.) per year
Armagh	St. Patrick's	86,000
Belfast	St. Peter's	25,000
Cavan	St. Patrick & St. Felim	52,000
Galway	OLAIIH & St. Nicholas	76,000
Kilkenny	St. Nicholas	74,000
Killarney	Assumption of TBVM	125,000
Derry	St. Eugene's	156,000
Longford	St. Mel's	200,000
Newry	St. Patrick's & St. Coleman	195,000
Sligo	Immaculate Conception	58,000
Waterford	Most Holy Trinity	116,000
Armagh	St. Patrick's	10,000
Kilmore	St. Fethlimidh's	6,500
Clogher	St. Macartan's	5,000

City	Cathedral	Number of attendees (approx.)
Down	St. Patrick	2,500
Dromore	Christ The Redeemer	18,000
Kildare	St. Briget's	1,000
Kilkenny	St. Canice's	6,500
Killaloe	St. Flannan's	1,700
Raphoe	St. Eunan's	3,600
Sligo	St. Mary & St. John	2,600
Trim	St. Patrick's	2,000
Waterford	Christ Church	7,500

These figures are calculated by taking the weekly attendances, which the sextons and sacristans were prepared to estimate and multiplying them by 52. It is not appropriate to deduce anything meaningful from this data except the obvious fact that RC cathedrals cater for much greater numbers than CI cathedrals which is not surprising given that the majority of people in the ROI who say that they are religious are Roman Catholics. In NI it is likely to be closer to 50%. This is shown by the Central Statistics Office (CSO) figures shown in Figure 4.23 taken from the 2011 census, which show clearly how large a percentage of the population who claim to be religious also claim to be Roman Catholic, compared with Church of Ireland.

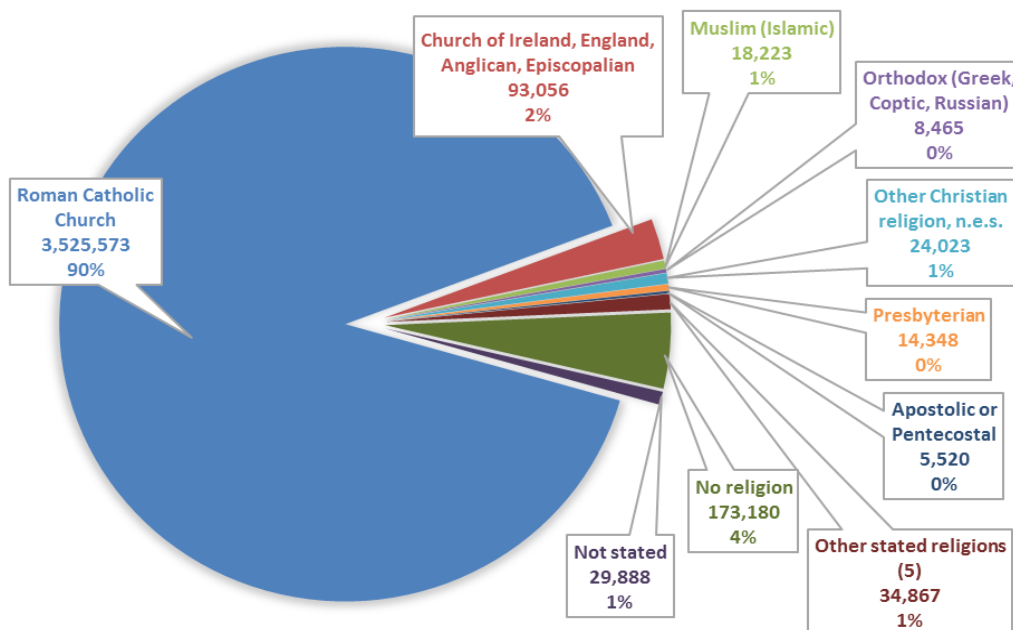

Figure 4.23 - Percentage of the population by religious denomination (CSO, 2011)

4.3 Heating

4.4.1 Heating Types

Details of the cathedrals together with the types of heating installed in each building can be seen in Appendix 27 and a breakdown of the heating installations is shown in Figure 4.24.

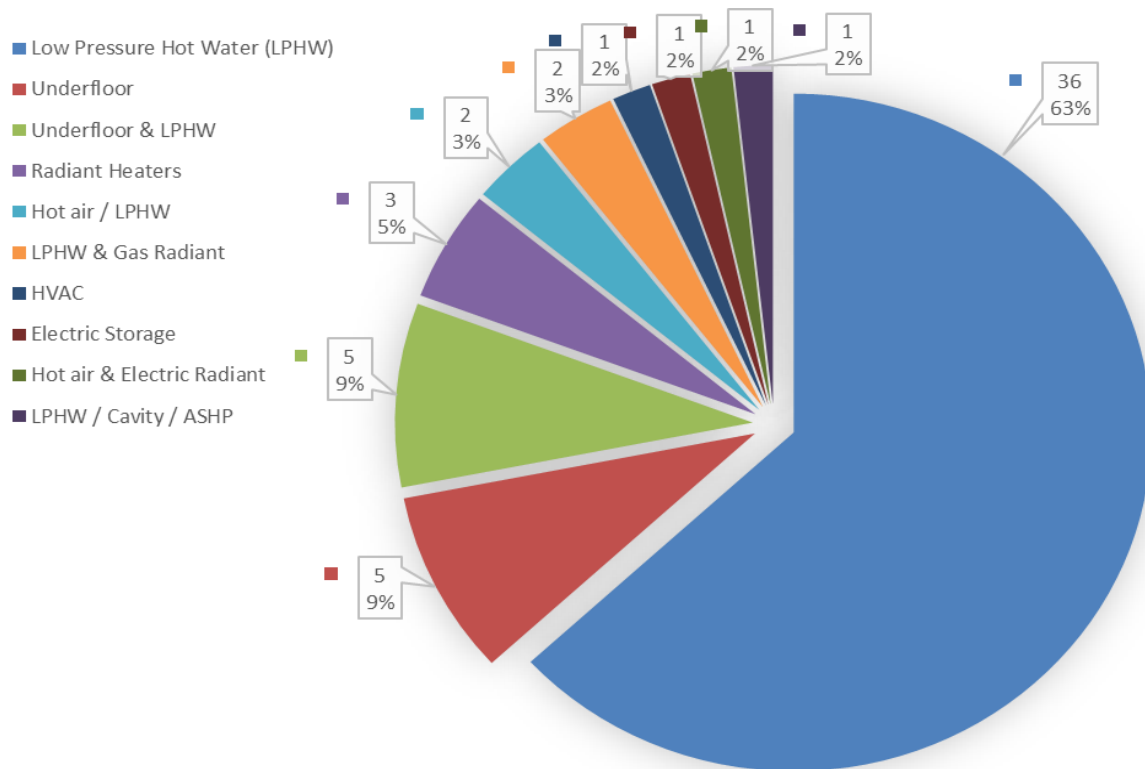

Figure 4.24 - Breakdown of heating types in cathedrals in Ireland

It can be observed that the LPHW system is the type of system most commonly installed (63%) as the heating system in Irish cathedrals (36 out of 57), although, whether they are the most efficient or the most appropriate, given the great changes of use which have taken place in recent years in these buildings, requires further research. Underfloor heating (10) is also prevalent in both stand-alone form and with additional sources. The most modern cathedral in Ireland, namely St. Mel's, uses this form of heating backed up by trench heaters. It is perhaps interesting that this is the form of heating chosen for a Roman Catholic cathedral in the 21st century given the way that St. Mel's, and indeed most Roman Catholic cathedrals, are used, that is open all day and every day. The Roman Catholic cathedral in Armagh also has an underfloor heating system backed up with an LPHW system, details of which can be found in Chapter 5, but they do not use the underfloor heating in order to save money. This completely alters the heating regime in the cathedral and was almost certainly not what the consulting heating engineers planned when the system was installed.

There does not appear to be a correlation between heating types and religious group. The fact that there is a wide variety of different systems installed may be another indication of a lack of knowledge sharing amongst cathedrals but is more likely to be simply that when it comes to replacing or upgrading a system, the cathedrals upgrade the existing system because this may cause less damage to the building and be less costly, than putting in a whole new different system.

The uses to which the buildings are put, has a large impact on the internal thermal environment in the buildings. It would appear that only those cathedrals which have large tourist income, and this is

confined to Church of Ireland cathedrals because they often charge for entry, which Roman Catholic cathedral never do, keep the heating running continuously during the day, because they can afford to do so. Even though they may have only one service a day and perhaps for small numbers of people, the heating is kept on. St. Canice's CI cathedral keeps the heat on all day to keep the volunteers at the shop/entry desk thermally comfortable. Some cathedrals of both traditions which have underfloor heating only use it intermittently which this type of heating is not designed for. Underfloor heating works most effectively and efficiently when left on at a low temperature for long periods. There is quite demonstrably no one solution which suits all cases but that does not mean that the systems which are there could, in some cases, not be used more efficiently.

Some cathedrals maintain a high ambient T (and thus low RH) even when the building is only being used by visitors who are constantly moving. Dropping the T could greatly reduce their costs and carbon emissions. Others allow the ambient T to drop substantially between events in the cathedral and no evidence was shown that they have considered maintaining a low ambient and then boosting it for events.

Most of the cathedrals do not have heating controls within the buildings and most systems are either all on or all off on a timer basis. Evidence obtained during the visits showed that few cathedrals had the ability to zone various parts of the building without manually turning radiators on and off. This might be particularly relevant to cathedrals where the numbers attending services are small compared with the size of the building. Those cathedrals where large numbers attend some services and smaller numbers attend others could benefit from being able to zone the heating. Some cathedrals such as Belfast, St. Peter's and Belfast St. Anne's have overcome this issue by having part of the nave glassed off, thereby creating a completely separate area which can be used for smaller congregations and thus need to be able to control local heating. Most cathedrals still heat the whole building for services and not specifically the people in the building. Exceptions to this are those cathedrals heated by radiation such as Belfast, St. Anne's and Lismore. This will be discussed further in Chapter 5.

When renovating or upgrading, it is obviously easier to replace the heat source, in other words the boiler, and perhaps to change the fuel used, rather than to change the whole system. Pipe runs and radiators will often outlast the boiler although it may be worthwhile replacing old radiators with more modern and more efficient ones. During this project Kilkenny RC cathedral upgraded its heating system by replacing the gas boilers and by extending the heating into the sanctuary area. Letterkenny replaced one oil-fired boiler with two more modern and efficient oil boilers. It also installed a building management system (BMS) and further research is recommended to study the effects of this.

Some cathedrals have completely changed the heating system since they were first installed. For example, St. Anne's in Belfast which originally had a hot air system, the remains of which are still in place, is now heated purely with electric radiant heaters. Lismore cathedral had an LPHW system but now also uses only electric radiant heating. Cloyne cathedral had an LPHW system but now, because of reduced sizes of congregation, uses electric storage heaters. The oldest cathedrals, such as St. Patrick's, St. Canice's and Christ church would have started with stoves heating parts of the building before installing coal fired LPHW systems and now have oil and gas-fired LPHW systems. Intermittently used LPHW systems, as will be shown in Chapter 5, produce very different results from LPHW systems which are in continuous use.

Stratification was not found in St. Patrick's (Corcoran, 2010) but may well be an issue in such cathedrals where intermittent LPHW systems operate. Further research is required to see if stratification exists and what effect, if any, it has on the internal environment in the buildings.

The survey showed a number of cathedrals with combination systems, such as trench and underfloor or LPHW and radiant heating and this is likely, for cost and usage reasons, to be a good solution, particularly for sparsely used CI cathedrals. It would be possible, if finance permits, for them to keep, for instance the LPHW systems for those few occasions such as Christmas and Easter when the cathedral is full and have another system such as radiant heating for the regular but sparsely attended Sunday services. Radiant, particularly electric heating, is easy to install retrospectively and with new technology, such as LED lighting with radiant heaters incorporated into the lights, this might alleviate the present perceived unsightliness of these systems.

With the exception of Old Loughlin where they have installed an air source heat pump in the belfry and put photovoltaic panels on the roof of the newly installed toilets, there are currently no Irish cathedrals with any type of renewable or sustainable heating system installed. During visits the main reason given for this was aesthetic rather than cost. The introduction of solar roof tiles such as those manufactured by the American car and battery company, Tesla, may help to alleviate this issue, especially as prices for such tiles fall, as competitors enter the market. St. Mel's does have the ability for both connections to a district heating system and to solar thermal panels as shown on the drawings which were provided to the researcher. It seems that with most cathedrals having large South facing roofs that this issue of renewables is likely to become more important in the near future.

The location of the boilers was varied but many were underneath the cathedrals, such as in St. Patrick's in Dublin, Cobh, Galway, Down, Killaloe and the Pro cathedral in Dublin to mention a few. Figure 4.25 shows the sophisticated entry system, with pneumatic opening doors, to the boiler room in St. Patrick's cathedral Dublin.



Figure 4.25 - Entrance to the boiler room of St. Patrick's cathedral, Dublin

Some boiler rooms were in separate buildings near to the cathedral such as in Ballina and Ballyhadareen. Obviously the further the boiler is from the building the greater will be the opportunity for heat loss. Most boiler rooms were tidy and were used only for one purpose, but some were also used as storage rooms. Access to the boilers was not always easy which must have made regular maintenance more difficult. It was not possible to establish how many will have to be replaced within say the next ten years but presumably the diocesan architects would have this information. Further research would be needed in this area. However, some boilers were clearly old and had had many obvious repairs. These boilers are likely to be inefficient especially if they are not of the condensing type. The people who were interviewed often did not know if maintenance contracts existed for the systems, but some people did say that the boilers were only serviced when they broke down. This was to save money by not having a regular service contract. Whether any type of cost benefit analysis had been carried out to see if in fact this saved the relevant cathedrals money in the longer term, is not known. This issue of maintenance and replacement of old and inefficient boilers may be a large one but could easily be established by carrying out an energy audit on each building. Where boilers are old and inefficient there must be a significant opportunity to save money by specifying the right type and size of boiler on replacement and so reducing the pay-back time substantially. It was clear that some boilers were large enough to provide the necessary heat but were being used in a manner for which they were not originally designed while other boilers were not large enough to cope with the increased levels of thermal comfort being demanded. This was evidenced in the results in such cathedrals as Old Leighlin and Kildare

Many cathedrals have obviously well run and maintained heating systems. A clean boiler or boilers, situated in a separate uncluttered room, with well lagged pipes and with manuals and tools laid out properly, are signs that the system is being well maintained. Examples of this are St. Patrick's in Dublin, Armagh RC, Letterkenny, St. Fin Barre's, Mullingar and St. Mel's cathedrals, to name but a few. A forum for sharing ideas on, for instance, heating system maintenance, could be beneficial for all. There must also be a case to be made now for sharing ideas on renewable and sustainability.

In conclusion it is possible to observe a number of solutions being used to solve the same issue namely to provide a level of thermal comfort to the people using these buildings. The system chosen

will no doubt depend on a number of parameters such as age, usage, religion, size, and location but it is also the case that no one solution, because of all of these differences, will be optimal in every case. What may be becoming clear is that some cathedrals could benefit from a combination of systems to cater for their changing patterns of use.

4.4.2 Fuel Used

Figure 4.26 below illustrates the percentage of cathedrals which use electricity (10%), gas (39%), and oil (51%) to heat their internal environment. It is noticeable that there is 100% dependency on fossil fuels. In 2008 the Carbon Trust in England carried out a survey of the churches in England and found that 43% used natural gas and 21% used oil which is quite different from the split in Ireland as shown in Figure 4.26. Also noticeably no cathedrals are using biomass or wood pellets as fuel. There are storage problems with these types of fuels but some cathedrals are rural based and might not have storage issues for these types of fuels. There are also ash removal issues with these fuels. England carried out a survey of the churches in England and found that 43% used natural gas and 21% used oil which is quite different from the split in Ireland as shown in Figure 4.26.

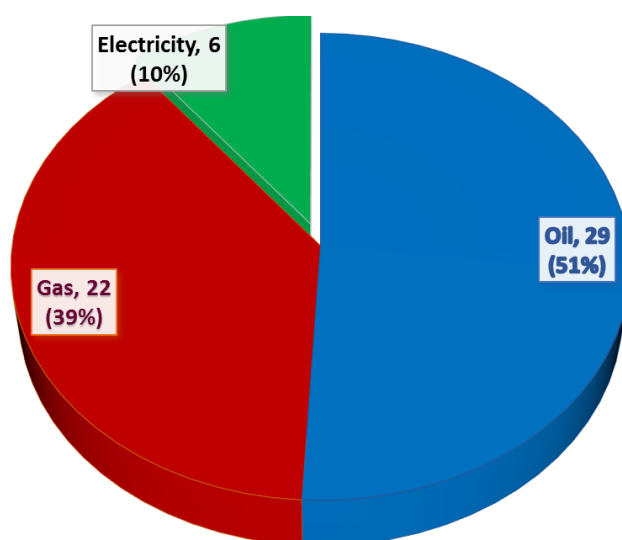

Figure 4.26 - Types of fuels used for heating systems in Irish cathedrals

The full data from which this graph was produced is provided in Appendix 27 (Cathedral energy usage analysis) This appendix includes the name and location of the cathedral, the boiler type, heating type, size of the building and the fuel used.

Electricity is used in a small number of cathedrals (10%) such as Cloyne where they have electric night storage heaters and in St. Anne's in Belfast and Lismore which have electric radiant heaters. St. Mary's in Cork has small electric radiant heaters which supplement the hot air system, but more detailed research would be required to see how much energy both systems consume in this cathedral. Kilfenora, the smallest cathedral in Ireland, has an underfloor electric heating system but it is only turned on very infrequently because they only hold three of four services per year.

Old Loughlin cathedral which is small (1,600m³) and old (12th century) uses an oil-fired boiler with an LPHW system to heat the nave but uses an air source heat pump to supply warm water to pipes embedded in the walls between the nave and the sacristy. The size and capacity of the system were not known by the dean of the cathedral. The electricity for the heat pump is partly supplied by photovoltaic panels situated on the roof of the new toilets which they recently built. This is the only cathedral in Ireland with such a uniquely sustainable system although St. Mel's has been rebuilt with facilities for future solar thermal and district heating connections. Although electricity is produced to power the heat pump, this cathedral was included in the category which uses oil.

The split between gas (39%) and oil (51%) could be for a number of reasons. For instance, mains gas may not be available near the site and there may not be room for large storage tanks on the site. Some gas-powered systems do have small gas tanks situated near to the cathedral such as in the Church of Ireland cathedral in Kildare as shown in Figure 4.27. This is unsightly and not optimal, though perhaps practical for the users since the tank is situated near to the gates of the cathedral which makes it easy for deliveries.



Figure 4.27 - St. Brigid's cathedral Kildare, gas storage tank

A number of cathedrals also have oil storage tanks beside the buildings such as shown in Figure 4.28.



Figure 4.28 - Oil storage tank beside Enniskillen cathedral

Other examples where oil tanks are situated beside cathedrals are Cobh and Letterkenny, but they are particularly unsightly and if these were classified as commercial buildings then berms would have to be fitted around the tanks which would only increase their bulk but would also improve their

safety. The oil tank beside Killarney cathedral is a short distance from the cathedral which means that it can be hidden with fences and planting.

Galway cathedral changed over recently from oil to gas partly because of a fear of oil leakage into the nearby river. Their oil storage tanks were beside but below the level of the cathedral and with the cathedral being on an island there was a real fear of contamination to the local water supply in the event of a leak. The oil tanks were replaced with gas storage tanks. In 2008 the Carbon Trust in England carried out a survey of the churches in England and found that 43% used natural gas and 21% used oil which is quite different from the split in Ireland as shown in Figure 4.26.

There was no evidence of cathedrals co-operating together for the purchase of fuel which might have enabled economies of scale to be used to reduce costs.

The fairly even split between oil and gas does not appear to show any pattern with regard to usage or size and seems to depend more on availability of fuel. One remote CI cathedral did comment that oil theft was a problem, but that gas was not available locally from the mains.

4.4.3 Types of Boilers

The data on boiler types proved surprisingly difficult to establish for a number of reasons. Occasionally access to the boiler room was not allowed and those interviewed did not have any details of the boilers. The main problem however was that many boilers were old and any manufacturers name had long since disappeared together with any maintenance manuals. There were occasions when the names of the boilers were easy to establish, such as in Enniscorthy (Roman Catholic) Cathedral and of Down (Church of Ireland) Cathedral, as show in Figure 4.29 below.

Even when the actual make and model number are available, such as in Waterford RC cathedral (Buderus Laguno GE515), it is observed from the manufacturer's data that two outputs for the same model are available, namely 455KW and 510KW and it is not possible, by inspecting the boiler, to tell which one is installed.

Many cathedrals do not have regular maintenance contracts and so contacting the maintenance engineer was not an option to obtain details of the boilers. The cathedrals with no maintenance contracts generally rely on local plumbing services who are called in when the system fails.



Figure 4.29 - Enniscorthy's boiler room and the boiler room in Down Cathedral where the names of the boilers are legible

One manufacturer of boilers uses a different designation for the boiler model depending on how many cast iron segments are added to the combustion chamber. To establish which model was installed would have required some dismantling of the boiler, such as removing the outer casing and it was extremely unlikely that permission for this would have been given. Where manuals were found they tended to be installation manuals rather than maintenance and running manuals and they covered all of the manufacturer's models under a particular brand name. Without knowing the model number of the boiler it was not possible to extract the details of the particular boiler being investigated on site.

Figure 4.30 however shows examples, in Enniskillen and Killarney, of cases where it was impossible to establish the boilers' exact name and model number since the names had long since disappeared.



Figure 4.30 - Boiler room in Enniskillen (left) and boiler room in Killarney (right)

Whilst there was a great variety, usually depending on age, of boiler types, the burners were of a more uniform make being largely a brand called RIELLO of various models. Riello is an Italian company which was founded in 1923 and which supply burners for use with a variety of fuels. Again there is an issue with not knowing which model of burner is being examined since the model numbers are not displayed on the burners. A typical data sheet from this manufacturer is shown in Figure 4.31 which lists all of the models available in a particular series.

RIELLO 40 FS SERIES
Overall dimensions (mm)
BURNER

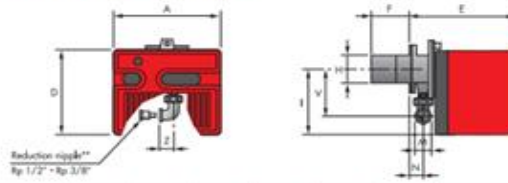

MODEL	A	D	E	F	H	I	M	N	V	Z
► F53	252	215	230	100	91	165	Rp 3/8**	37	132	25
► F55	272	233	295	100	91	180	Rp 1/2"	48	138	28
► F58	305	262	347	110	105	204	Rp 3/4"	61	142	33
► FS10	305	262	346	110	105	204	Rp 3/4"	61	142	33
► FS15	350	298	389	120	125	230	Rp 3/4"	67	152	33
► FS20	350	298	389	120	125	230	Rp 3/4"	67	152	33

* With reduction nipple
 ** Standard equipment on Riello F53

Figure 4.31 - Popular make of burner but with a number of models on the same data sheet

According to the company's web site in 2005 they sold over 500K units worldwide.

Those boilers which did not have service contracts may not be operating at maximum efficiency and the reason that service contracts are not in place is, according to the interviews carried out, exclusively, to save money. Newer systems, such as the one found in St. Mel's (Longford) and Kilkenny Roman Catholic (St. Mary's) Cathedral, have service contracts for the maintenance of the boilers and heating systems.

Boiler makes observed to be in use in Irish cathedrals are as follows. The particular model numbers are not specified for the reasons given.

- Buderus
- Chappee
- CR Remeha
- Do Dietrich RBL
- Elco Klockner
- Fermus
- Ferroli
- Haworthy
- Hodfors
- Potterton
- Remeasurt
- Tasso

Research has shown that a number of these companies are either no longer trading or have amalgamated with other companies.

A list of the cathedrals and the boilers installed in them, where they can be identified, can be observed in Appendix 27.

The widespread lack of information available from those interviewed shows how important it would be to be able to interview more than one person for each cathedral. The necessary information about the boilers should be available but the task would be to find out who is in possession of it. An energy audit, which is one of the final recommendations of this thesis, would clearly need to give details of the boilers including name, model number, age, performance, efficiency, power and so on and this information is essential for the efficient running and proper maintenance of the systems.

4.4 Performance

Performance figures were not available for the various heating systems in the cathedrals in Ireland for reasons as outlined in Section 4.4. However it is interesting to note that in the UK the Chartered Institute of Building Services Engineers (CIBSE) produced a benchmark for ecclesiastical buildings as reproduced in Table 4.4.

Table 4.4 - Comparison of good and usual practice of various operational heating systems in the UK

	Good Practice	Typical Operation
Fossil Fuel	80 KWh/m ²	150 KWh/m ²
Electricity	10 KWh/m ²	20 KWh/m ²

In 2013 and 2014 the Church of England carried out an energy audit on its real estate and found that cathedrals, which represent 0.14% of the built estate actually emit 2% of the carbon emissions. This is because cathedrals have a larger floor area than most churches and they often have a higher level of occupancy. The Church of England, in conjunction with CIBSE (Chartered Institute of Building Services Engineers) benchmarked a range of building types and for churches they came up with a typical energy use for a gas heating system of 170kWh/m²/year (Church of England, 2012/2013).

Had all of the requested information been available, it would have been possible to produce a table such as Table 4.5 which was compiled by a research assistant under the supervision of Prof. West (Carvalho, 2017). In this case, all of the necessary financial and performance figures were available for each of three small Ci churches in Ireland and this enabled accurate energy per capita per service/per annum data to be produced. A similar table should be produced for all of the cathedrals when and if the information is made available.

Nothing is known about the carbon emissions in Irish cathedrals. Table 1.1 sets out the figures for the Church of England, but these do not, obviously, include Roman catholic cathedrals which have a different usage pattern and hence, presumably a different production of CO₂

Table 4.5 Usage analysis for the churches.

Churches Energy Usage Analysis																	
County	Town/ City	Name of Church	Date built	GPS Coord.	Size (m ³)	Fuel used	Heating type	Cost per year to heat 2015	Cost per year to heat 2016	Avg. cost per year per m ³	Number of services per year	Num ber of seats	Number of people at religious services per year	Cost to heat per person year 2015	Cost to heat per person year 2016	Cost to heat per hours open a year	Hours open per year
CHURCH OF IRELAND																	
Wicklow	Delgany	Christ Church	1789	53° 7' 58" / 6° 5' 19"	5,362	Oil	Central heating	€3,327	€2,905	€0.58	163	450	2,461	€0.59	€0.50	€5.92	526
Wexford	Inch	Inch Church	1831	52° 44' 25" / 6° 14' 10"	1,069	Electricity	Infrared wall mounted & storage heaters (always on)	€2,082	€2,581	€2.18	54	80	1,229	€1.69*	€2.10*	€28.78*	81
	Fethard-on-Sea	St. Mogue's Church	1684	52° 11' 35" / 6° 50' 21"	864	Electricity	8 infrared heaters + 1 bar heater (never on)	€650	€695	€0.78	54	152	1,116	€0.58*	€0.62*	€6.23	108

*Note: Cost to heat per person including lighting

4.5 Observations and Recommendations

This chapter has shown much about cathedrals in Ireland and identified much that is not known. It is considered that what is not known presents as many opportunities as what is known, to the managers of these buildings. What is clear is that the managers of these buildings need to gather in one place all that is known about the buildings so that an holistic approach can be taken about the heating and energy use, amongst other things.

Observations

- These are complex buildings with differing heating needs based principally on their size, usage and financial resources as well as the different traditions.
- Thermal comfort and cost are the prevalent concerns not conservation and preservation.
- There was no evidence that the managers of these buildings co-operate with each other with regard to sharing best practice or in using their undoubted purchasing power in the procurement of fuels.
- The use of smart meters was not observed in any cathedral.
- There was no evidence of any targets for carbon or greenhouse gas reductions.
- BMS systems were only in evidence in a small number of cathedrals.
- LPHW is the preferred heating system in Irish cathedrals.
- Oil is the preferred fossil fuel used to heat the buildings.
- Only one cathedral uses any type of renewable energy.
- There is 100% dependency on fossil fuels for heating (the one cathedral which has photovoltaic panels also uses oil for the boiler.)
- In over 90% of the cathedrals it was the whole air mass in the building which is being heated and not just the people using the building. Two notable exceptions being Belfast CI and Lismore, both with electric radiant heating.

Recommendations

- A comprehensive survey of all of the heating systems should be undertaken to ensure that they are operating at reasonable efficiency, regardless of the age of the system.
- An energy audit should be carried out in each cathedral using smart meters and software such as sMeasure©. This would provide vital information to the cathedral managers concerning energy use and may enable substantial cost savings to be made.
- A forum should be set up centrally so that best practice ideas can be shared amongst the managers of the buildings. If doing this centrally is too difficult then it could be done by diocese so that all the churches in the diocese could benefit from this knowledge sharing.

- The purchasing of fossil fuels should be done centrally to benefit from the obvious buying power which such a large real estate portfolio undoubtedly gives. Again, this could be done by diocese but the benefits might not be as great as if it was done centrally.
- A BMS should be installed in all cathedrals to ensure maximum efficiency in the use of energy.
- Realistic targets for the reduction of green-house gases and carbon emissions should be set, centrally and locally, with a proper reporting structure incorporated.
- Cathedrals should be considering the use of renewable energy so that when their existing systems need replacing they will have the necessary information needed to make an informed decision.
- Simple heating controls should be installed in the existing systems so that zoning of the building can be achieved.
- Thermostats should be correctly installed and utilized.
- Those cathedrals which do not have maintenance contracts should carry out research to decide if this is cost effective.
- Some heating regimes are causing damage to the pipe organs. Research should be carried out to see if it is more cost effective to retune the organ on a regular basis or to adjust the heating regime.

It was an unexpected but critical finding of the research, largely shown by the questionnaire, that there are serious deficiencies in the administration and management of the heating systems within Irish cathedrals. There are deficiencies with regard to the management, information systems and training of personnel. There is often little local knowledge and control concerning the operation of the systems and no centralised monitoring of these systems. There is no knowledge sharing, no centralised purchasing and a general lack of information, at least at local level, about the buildings and their heating systems. Multiple people and agencies appear to have information about the buildings, but these people and agencies do not appear to communicate with each other. The cathedrals administrative systems, with regard to the buildings themselves, appear to be not fit for purpose and could reasonably be described as dysfunctional.

5 Data Logging Results and Analysis

5.1 Analysis by Size

Over 100 visits to the 57 active cathedrals were made, these being for the initial visits and then to install and remove the equipment in those representative 25 cathedrals of the active 57, which represents 44% of the total number of cathedrals. In addition, extra visits were required to check on previously acquired data where the data suggested an anomaly or simply to double check the data. Each monitored cathedral had five data loggers (six in the case of Christ Church cathedral, Dublin) and one TinyTag installed. Each logger and TinyTag was programmed to record Temperature (T) and Relative Humidity (RH) every five minutes which, over a month, resulted in over 8,000 readings per logger or approximately 50,000 readings per cathedral or over 2.4 million units of data in total.

This volume of data could be analysed in several ways such as by heating type, by location, by religion, by usage or by age, to name but some, in order to compare and contrast the thermal and moisture environment of the various buildings. However, it was believed that categorisation by size, initially, provided the clearest method for analysing such a large volume of data. Obviously the larger the space to be heated the more energy is required. Size is one of the dominant determinants in affecting the internal thermo-hygrometric environment in cathedrals along with usage and heating type. The breakdown of the analysis is shown in Figure 5.1.

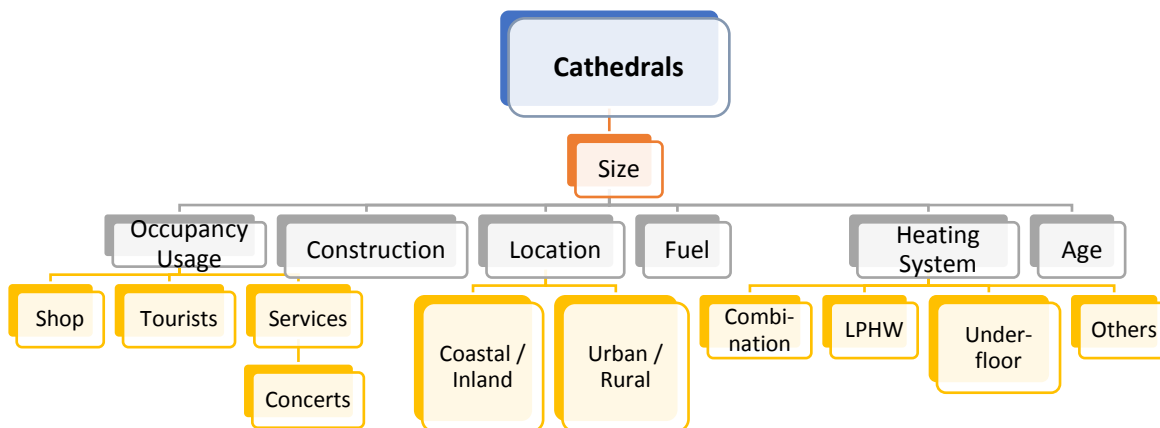

Figure 5.1 Scheme of categories in which the project's data was divided and analyzed

5.1.1 Very Large Cathedrals

The way in which the cathedrals were divided up by size was somewhat arbitrary and does not conform to any formal categorisation by size, if such indeed exists. By international standards Irish cathedrals are small. When one considers that Seville cathedral (Cathedral of Our Lady of the See) in Spain, which is reputed to be the largest cathedral in the world, has a volume capacity of some 500,000m³, it will be noted that Ireland's largest cathedral, namely Galway, at approximately 44,000m³ is modest in size by comparison. However, as previously stated, Irish cathedrals were built

for purpose and not as status symbols. According to IS7913 (2013), ‘Societies, communities and powerful people of all periods have used their principal buildings as a means of expressing their authority, sanctity, wealth or sophistication, and often all of these things at the same time.’ This was generally not the case in Ireland because it was a poor country that could not afford to build such very large ecclesiastical status symbols such as are found in England and France. Using the supposition that any cathedral in Ireland over 30,000m³ is considered very large for the purposes of this study, it may be observed that there are nine cathedrals, as set out in Table 5.1, which fall into this category.

These cathedrals are spread across various parts of the island and this for different historical reasons. The list includes some of the oldest cathedrals in Ireland namely St. Patrick’s in Dublin (CI) (circa 1192) and St. Canice’s in Kilkenny (CI) (circa 1270) as well as some of the newest such as St. Anne’s in Belfast (CI) (1981) and Our Lady Assumed into Heaven and St. Nicholas in Galway (RC) (1965). St. Patrick’s RC cathedral in Armagh (1904), which also fits into this size category, is the seat of the Roman Catholic Archbishop of Armagh and Primate of all Ireland.

Table 5.1 Very large cathedrals (greater than 30,000 m³), showing age, heating type and fuel used

City	Name	Size (m ³) (approx.)	Age	Heating type	Fuel
Galway*	Our Lady Assumed into Heaven & St. Nicholas (RC)	44,000	1965	Underfloor	Gas
Newry	St. Patrick & St. Coleman (RC)	41,400	1829	HVAC	Gas
Cobh	St. Coleman’s (RC)	38,000	1919	Underfloor	Oil
Armagh*	St. Patrick’s (RC)	37,000	1873	LPHW	Oil
Belfast*	St. Anne’s (CI)	37,000	1981	Radiant	Electricity
Monaghan	St. Macartan’s (RC)	36,000	1948	LPHW	Gas
Dublin*	St. Patrick’s (CI)	35,000	1254	LPHW + radiant	Gas
Kilkenny*	St. Canice’s (CI)	35,000	1270	LPHW	Gas
Limerick	St. John’s (RC)	32,200	1894	LPHW	Gas

*Note: monitored

Six out of the nine (67%) cathedrals belong to the RC church and the remaining three to the CI. As these RC cathedrals were built within the last 150 years and considering Ireland’s turbulent history during that time, it was a considerable achievement to build such large edifices in such difficult and impoverished times.

Some of the unique features of the monitored very large cathedrals and which will explain why they were chosen to be monitored:

- Galway (RC) Heating system, insulation, usage, age.
- Armagh (RC) Importance of the cathedral, heating regime, location.
- Belfast (CI) Heating system, age, usage.

Dublin St. Patrick's (CI)	Age, usage, heating regime.
Kilkenny (CI)	Heating system, age, usage and its similarity to St. Patrick's CI cathedral.

Five cathedrals within this group were monitored, those marked with an asterisk in Table 5.1 with St. Patrick's cathedral in Armagh (RC) and St. Canice's (CI) cathedral in Kilkenny being monitored in both summer and winter. This was in order to establish the strength of any correlation between how the buildings reacted to ambient conditions in winter and summer.

Very large cathedrals make up 16% of the total number of 57 cathedrals and, of this 16%, 55% were monitored. This is a higher percentage of monitored cathedrals than other categories because it was observed that this group is quite diverse in terms of usage pattern and the group includes some of the oldest and youngest cathedrals, and as such they represented a reasonable cross-section of all the cathedrals of that size in Ireland

St. Patrick's, Dublin and St. Canice's, Kilkenny

It is appropriate to single out two of these very large cathedrals, namely St. Patrick's (CI) in Dublin and St. Canice's (CI) in Kilkenny, for comparison, as they have an unusually large number of attributes in common. Both are Church of Ireland cathedrals and are similar in size, being 35,000m³ and 31,000m³ in volume respectively and both are not dissimilar in age, namely dating from circa 1172 and circa 1270. Of the two cathedrals St. Patrick's has been altered more over the centuries, particularly in the late 1800s, but both have many features dating back to their foundations. The heat delivery system in each is different with St. Patrick's having five in-line condensing gas boilers, as shown in Figure 5.2, which were installed in 2007/2008. St. Canice's has one gas fired boiler. One of the boilers in St. Patrick's, the extreme right hand one in Figure 5.2, was taken off line shortly after installation to improve the ventilation in the boiler room. St. Patrick's was monitored from 27 February 2015 until 15 April 2015 and St. Canice's from 17 December 2015 until 3 February 2016.



Figure 5.2 Gas boilers in St. Patrick's cathedral, Dublin

St. Canice's is unique in that some of the pipe work, from one of the earliest heating systems installed in any cathedral and from a time when it was heated by coal fires, is still in place. Both cathedrals rely heavily on tourist income although the numbers visiting St. Patrick's, per annum, is more than the total number of tourists visiting all other Irish cathedrals. Both cathedrals charge visitors for entry, but not if attending religious services. This means that both cathedrals have accurate numbers for visitors which in the case of St. Canice's exceed 41,000 per annum and in the case of St. Patrick's exceed 500,000 per annum, which produce significant income for both cathedrals. The two cathedrals operate shops in the nave area of the buildings with St. Canice's being co-located with the reception desk while that in St. Patrick's is near to, but not connected to the reception desk. The two shops are focused on the tourist trade and sell items which would be found in any tourist shop with perhaps a slight emphasis on religious items. This is in sharp contrast with shops found in RC cathedrals which focus almost entirely on religious items.

The pipe organs found in both cathedrals are highly valuable from both an intrinsic and monetary point of view and both are used regularly. This makes the stability and level of both T and RH very important for the preservation of these instruments. Both cathedrals are situated in city centers with St. Patrick's being built in the Coombe on top of the River Poddle, a tributary of the River Liffey in Dublin. This has caused considerable problems for the building over the years in terms of subsidence and explains why this cathedral, unlike the nearby Christ Church cathedral, has no crypt. St. Patrick's cathedral is built in a valley and the water table is high in the area. The risks associated with this can be deduced in the boiler room which is actually situated below the water table with the water being held back by a steel frame around the boilers. On the other hand St. Canice's is built on top of a hill in the centre of the city of Kilkenny. Both St. Patrick's and St. Canice's are constructed with stone walls, stone flag and tiled floors with traditional slate roofs. Single glazed windows, both plain glass and stained glass, are used throughout both buildings. It is not known if the walls are solid stone or faced with stone and infilled with rubble, which is likely to be the case in at least some areas, as this was a normal building technique at the time of their construction. Fuller details of both cathedrals can be found in Appendices 10 and 15.

St. Canice's has a round tower very close to, but not connected to, the south transept. Galloway (1992) informs that the tower could have been built anytime between 700AD and 1000AD but in any event, it makes a valuable contribution to the cathedral finances as tourists pay to climb the tower and look at the fine views over the city of Kilkenny. There is also a bishops' palace, deanery and library nearby, but they are not part of this research. Likewise, St. Patrick's cathedral has a deanery and choir and grammar schools opposite the cathedral, but these too do not form part of this research.

Temperature

The position of the loggers installed in St. Patrick's Cathedral Dublin, can be observed in Figure 5.3 below and in Appendix 1 – St. Patrick's Church of Ireland Cathedral.

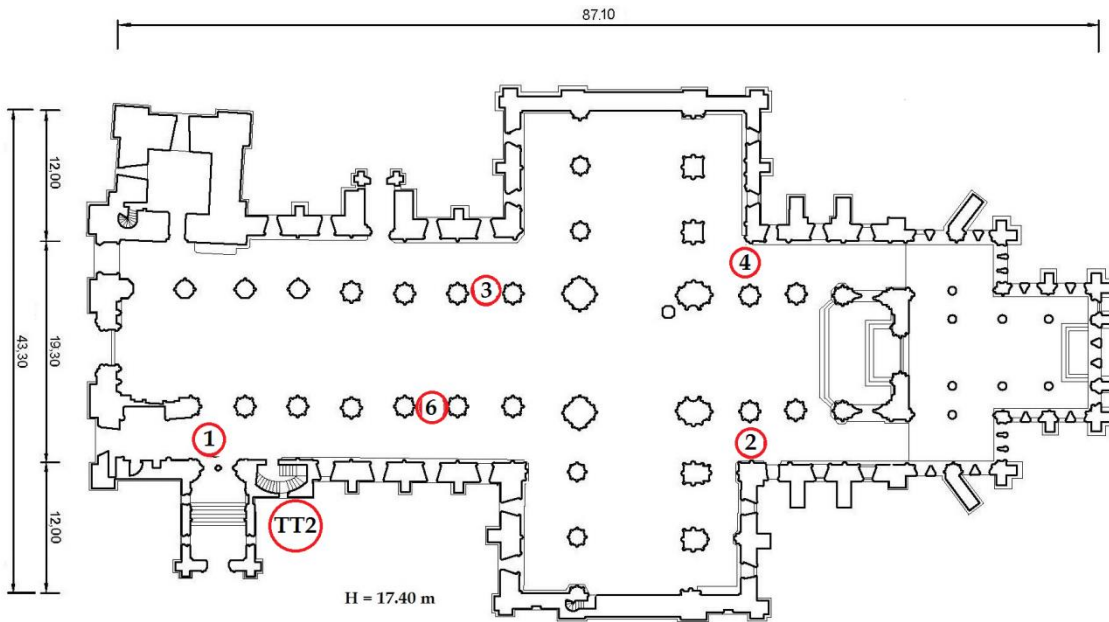

Figure 5.3 - Floor plan St. Patrick's Cathedral, Dublin (Col) with loggers and TinyTag location

Figure 5.4 shows the consolidated T readings in St. Patrick's cathedral during the monitored period. The graph shows that the daily rises and falls are small but sharp which would be expected from the relatively modern and powerful boilers which are installed. The internal ambient T is high at around 18°C, where it should be noted that the readings took place in March, which means that the boilers only need to raise the T by approximately 1°C each day as the heating is kept on constantly for long periods during the day and the thermal mass keeps the ambient high even during the night during the heating season.

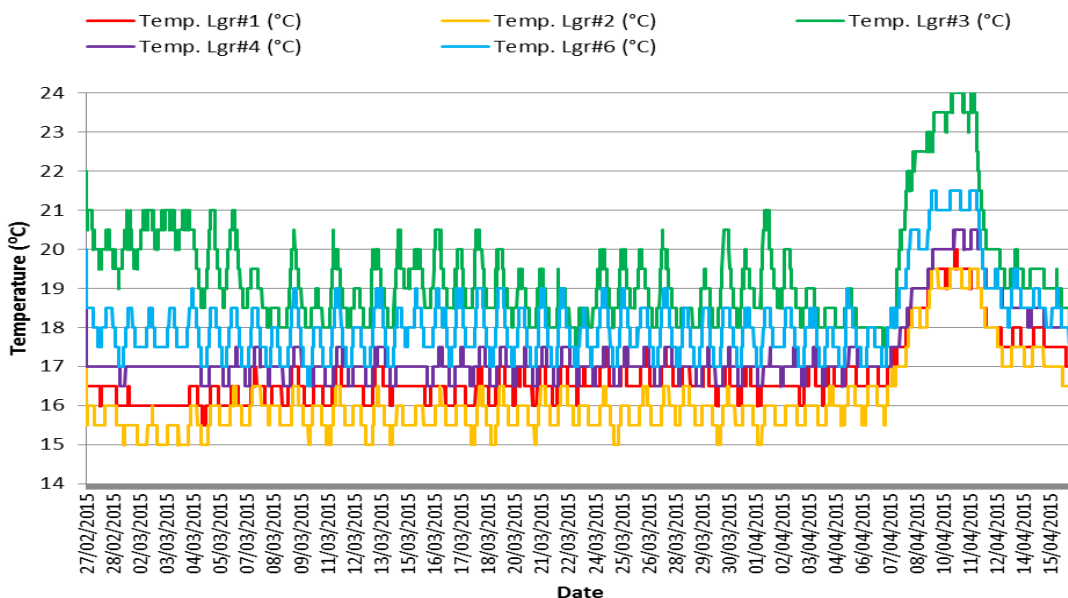

Figure 5.4 Showing the readings for T from all loggers for St. Patrick's cathedral, Dublin

A study carried out in St. Patrick's cathedral in 2009 by Corcoran of Trinity College Dublin into the heating around the organ also produced a mean ambient T of 18°C. This report also found 'that temperature and relative humidity are uniform throughout the building' (Corcoran, 2009). This largely confirms the findings of this research.

The more significant rise in T at the end of the monitoring period was as a result of Easter being at the beginning of April in 2015 and the large increase in the number of services and visitors at that time increased the T readings within the building. Logger 3 was placed, inadvertently, slightly closer to a radiator than the other loggers, which explains its slightly different profile. The TinyTag readings for the outside of this cathedral were not usable as the unit had been placed where it was exposed to direct sunlight during the day. The manufacturer's data sheet for the product did not mention that this should not be done, but subsequent contact with them showed that when the unit was placed in direct sunlight the case of the unit heated up, giving false high T readings. Even without these readings it is obvious that the internal T in St. Patrick's is not dependent on and nor does it follow, the outside T which will rise and fall much more than the 2°C range shown for the inside.

It is known that outside T readings in Ireland can vary by as much as 10°C during the night, in March in this case, as evidenced by Figure 5.7 which shows the temperature recordings for St. Canice's cathedral.

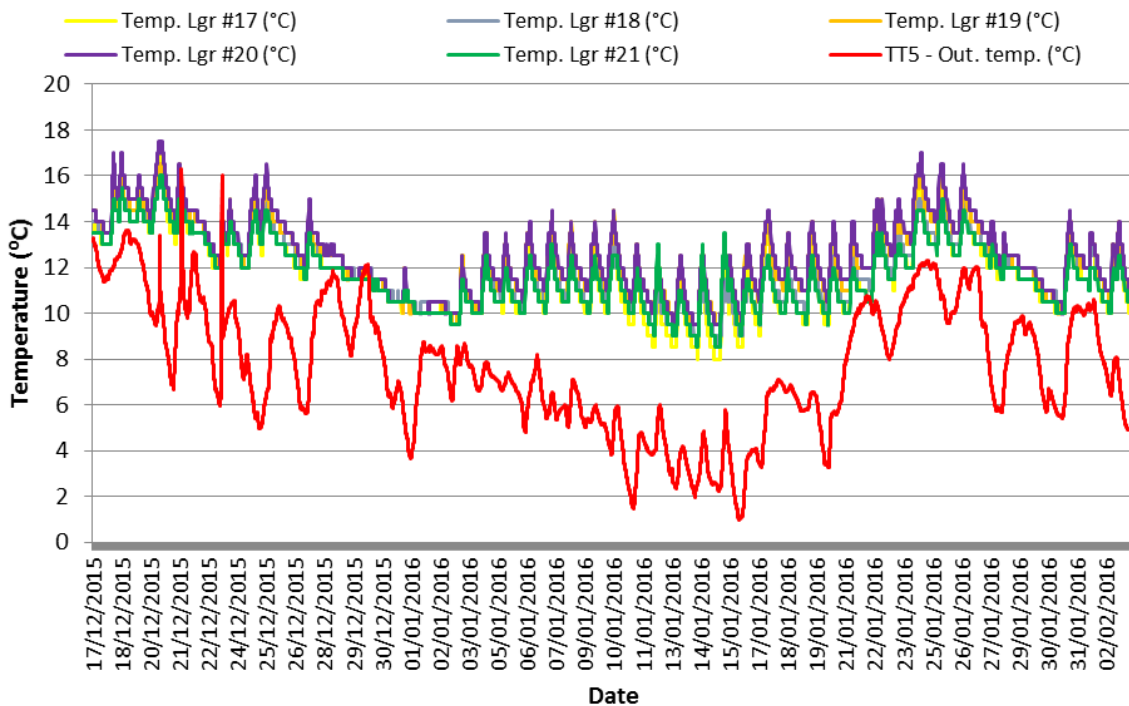

Figure 5.5 Readings for T for St. Canice's Cathedral (winter), Kilkenny

The location of the loggers in St. Canice's (winter) is shown in Figure 5.6 and Appendix 2.B.

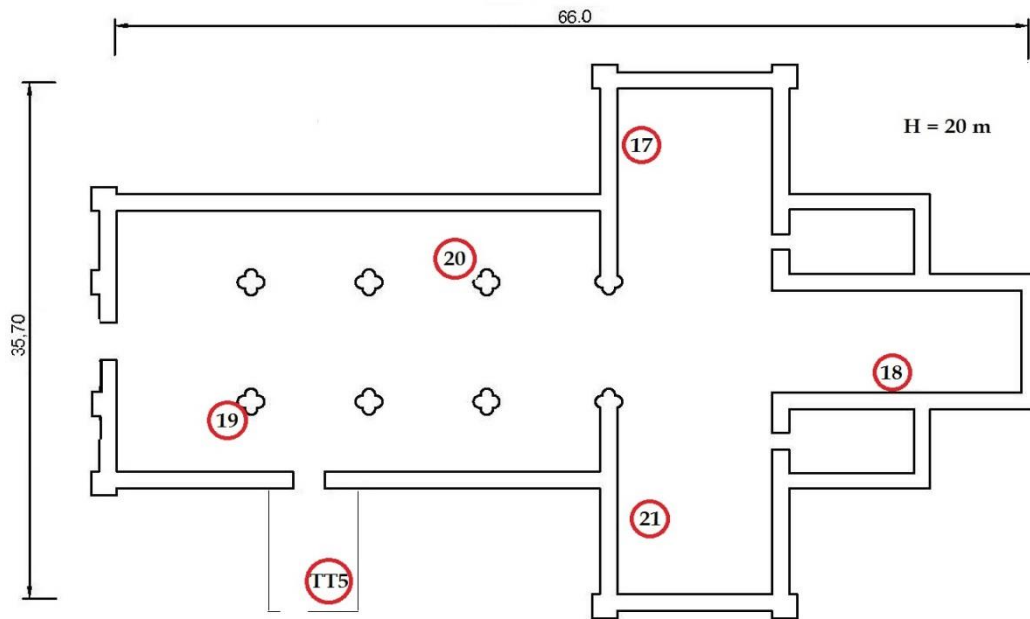

Figure 5.6 - Floor plan St. Canice's (winter)

In the case of this cathedral the daily rises and falls are much more pronounced than they are in St. Patrick's as the heating is only on for a set period during the day. The rises and falls are steep, but the ambient T is much lower than in St. Patrick's at circa 11°C, some 2-6°C above the external ambient. With a lower ambient T, the single boiler only raises the T by 2 or 3°C each day and even then, the ambient T does not rise as high as that found in St. Patrick's. The heating regimes in both cathedrals are quite different.

The outside TinyTag readings for St. Canice's show that the internal T follows the outside T quite closely except for the period before the New Year when the heating was switched off leading to initial T of about 10°C as the cathedral was closed to visitors and worshipers and then early in the New Year it was switched on again, creating a different inside environment with a maximum of 12-14°C experienced during the day for two weeks.

It is noted that the recording periods for both cathedrals are different which will, to some extent, explain differences in the average T for St. Patrick's when compared with St. Canice's. St. Canice's was monitored from December until February whereas St. Patrick's was monitored from March until April when the outside T would undoubtedly have been higher. However, this does not change the fact that both cathedrals have adopted quite different heating regimes which have produced quite different internal temperatures.

The outside TinyTag readings for St. Canice's show marked differences nocturnally and diurnally. It is noticeable how closely the internal and external T profiles match in this cathedral which indicates substantial heat losses from the building. This is expected with single glazed windows, an uninsulated roof, and an exposed hill top position for the building. Even allowing for the large thermal mass of the building, there is a marked difference between the day and night T measurements internally. St.

Canice's puts the heat on every day in order to keep the people working in the shop and the office reasonably comfortable thermally. The office is in the East transept of the cathedral and is not separated from the remainder of the building except with a small open screen. By contrast the offices in St. Patrick's cathedral are in a separate building. There are other ways which could be used to make the shop staff in St. Canice's more thermally comfortable, for instance with radiant heaters and heated carpets and the use of these means would obviate the necessity to heat the whole cathedral every day. The office area in St. Canice's could be separated from the cathedral with perhaps a full height glass screen and be heated separately, which again would obviate the need to heat the whole building each day. Whilst the visitor numbers visiting St. Canice's are high, at around 41,000 per year, they are concentrated in the summer months when heating of the cathedral is not required. Visitor numbers in St. Patrick's are highest in the summer months but visitors are present in the cathedral, often in substantial numbers, throughout the year.

If the T readings for St. Canice's cathedral are examined (Figure 5.5) between the dates of 25th December and 28th December one can observe that much heat is being wasted because the building, due to its thermal mass, slowly cools down and must then be heated up again. This is most noticeable around the end of the year when the heating was switched off for several days and the heat slowly dissipated as the building cooled towards the external ambient. This is not evident in St. Patrick's (Figure 5.4) as the heating is constantly maintained.

Figure 5.7 shows the rate per hour increase for T in St. Patrick's cathedral and the average is circa 0.2°C/hr which is very low, partly because the ambient T is high and the boilers only have to raise the T by a small amount each day. Logger 3, as was explained, was placed too near to a radiator and hence higher readings rates exist from this logger.

The rate of increase $\frac{\delta T}{\delta t}$ (in °C/hr) was calculated manually, because Excel, the software programme in which the results were displayed, was unable to recognise the changes in T when it increased or decreased. By visually examining each logger's readings and noting the time, t, when the T started to increase and t when it started to fall the differences and thus rates could be calculated. For example in the case of St. Patrick's (Figure 5.7) this involved 117 manual calculations to derive the rates for all temperature surges in the monitored period.

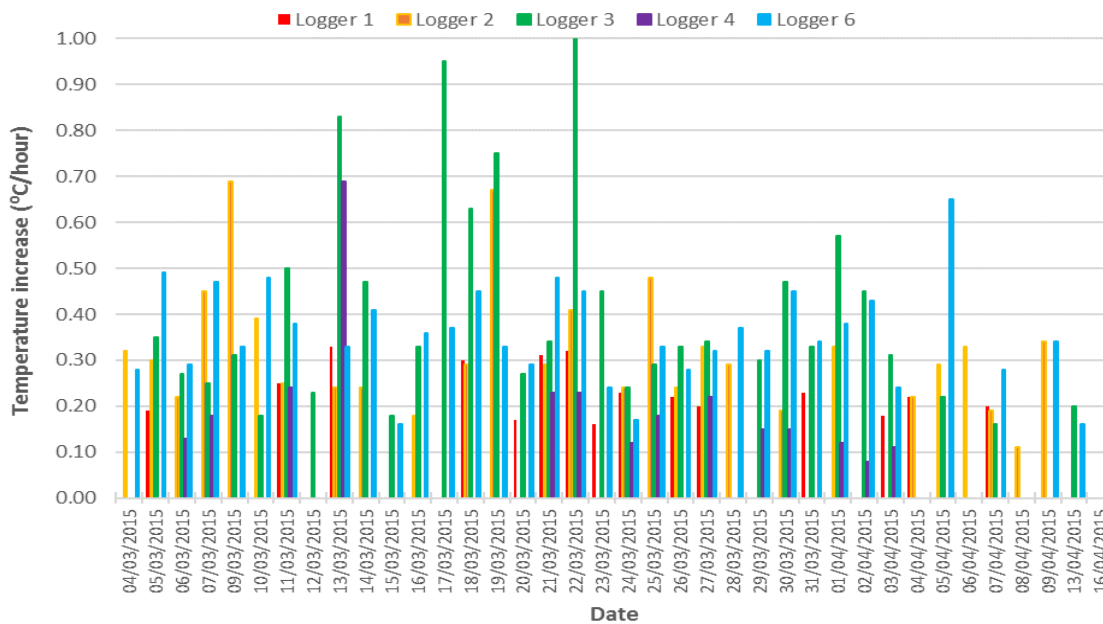

Figure 5.7 The rate per hour increase for each logger in St. Patrick's cathedral

The gaps in the readings in Figure 5.7 towards the end of the monitoring period are because there were no perceptible changes in readings over the period. The rate across the whole building is not entirely even but this is because this is a large building (around 35,000 m³) with complicated air movements and local heat gains due to radiators or solar gain.

The rate per hour increase for St. Canice's (in winter) is shown in Figure 5.8 and the average here is circa 0.5°C per hour which is over twice that of St. Patrick's. This is primarily because the ambient T is much lower and the boiler has to raise the T by more than 3°C each day as the heating is only switched on for a set period during the day. There may be no connection between the facts that a lower ambient may co-exist with a faster rise in T but it may be because the boilers are set to achieve a particular T setting and are powerful enough to do this within a set period of time given the cathedral size and heat losses. Where the ambient T is high, such as in St. Patrick's in Dublin, then the boiler only has to raise this already high figure by a small amount and may be able to do this quickly if the boilers are capable of doing so. A small boiler having to heat a large space is likely to produce a low rate per hour increase in T if the ambient T is already high. The rate per hour increase is dependent on a number of inputs including, the heating type, the size of the building, air losses through the building envelope, the power of the boiler and the radiators (LPHW system), and the temperature difference, in other words how much the T must be raised.

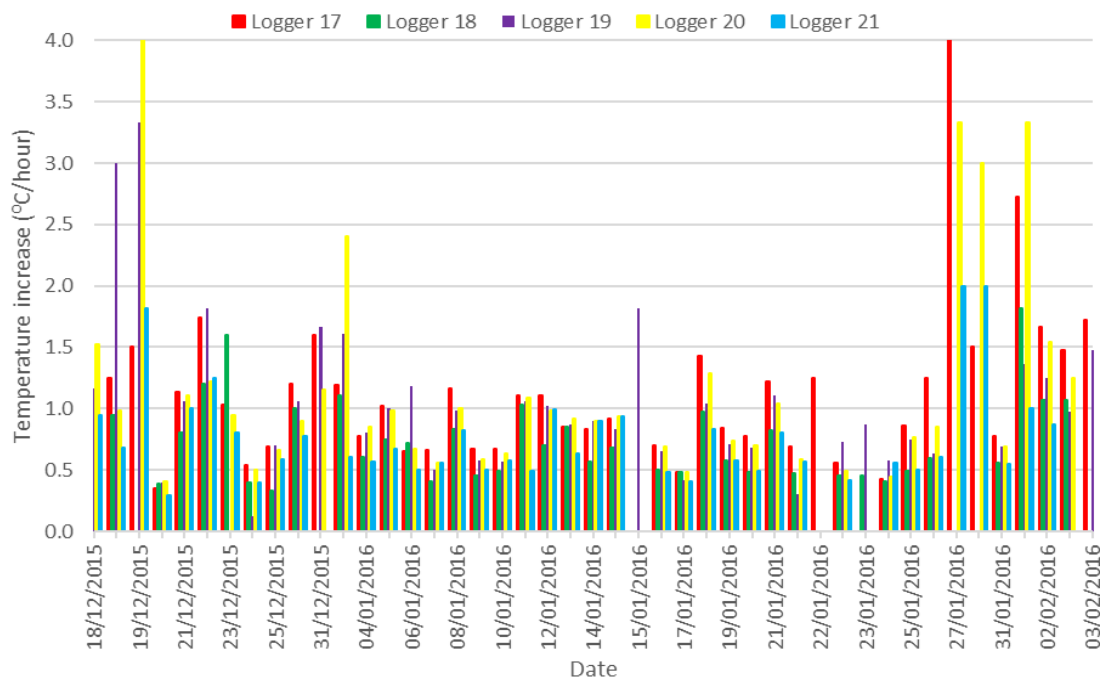

Figure 5.8 Rate of temp. increase per hour per logger in St. Canice's cathedral (winter)

The loggers are recording every five minutes and for any change over 0.5°C the rate is calculated so it is inevitable that there will be a few readings, such as with logger 20 in St. Canice's, which are outside the normal range. The spread of increase in Figure 5.8 throughout the building is quite even which is explained by the fact that (i) the building is not widely used during the monitoring period and would have stable air movements with doors to the outside being used infrequently and (ii) the heating regime and internal ambient are broadly uniform (see Figure 5.9).

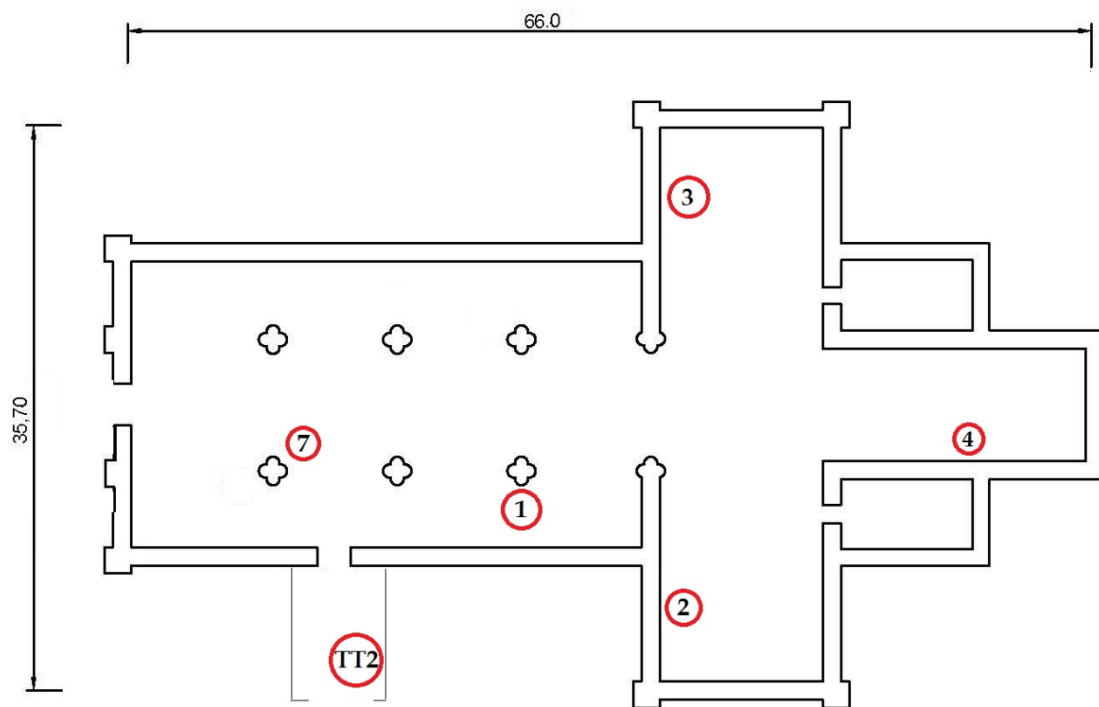

Figure 5.9 Floor plan showing the location of the loggers in St. Canice's Cathedral, Kilkenny (summer)

St. Canice's was also monitored during the summer months and the logger readings for T are shown in Figure 5.10 and in Appendix 2B. The various loggers show highly uniform readings throughout the building (with daily fluctuations usually lower than 0.5°C) where the loggers were placed in the same place in the summer as they had been in the winter. This clearly shows that a general rise in the outside T was followed by a smaller, slower but commensurate rise in the inside, despite the wide daily range outside. As in the winter, this cathedral, because the heating is turned off during the night, is in a situation where the inside T movements mirror the outside with a lag, and much smaller daily variations. This is quite unlike St. Patrick's where, because they can afford to keep the heating on continuously during the winter, they can, in effect, isolate the interior of the building from much of the T movement in the outside environment. Had St. Patrick's been monitored during the summer months it is very likely that the inside T, just as it did in St. Canice's, would have mirrored the outside T as there was no internal heating to regulate the internal environment.

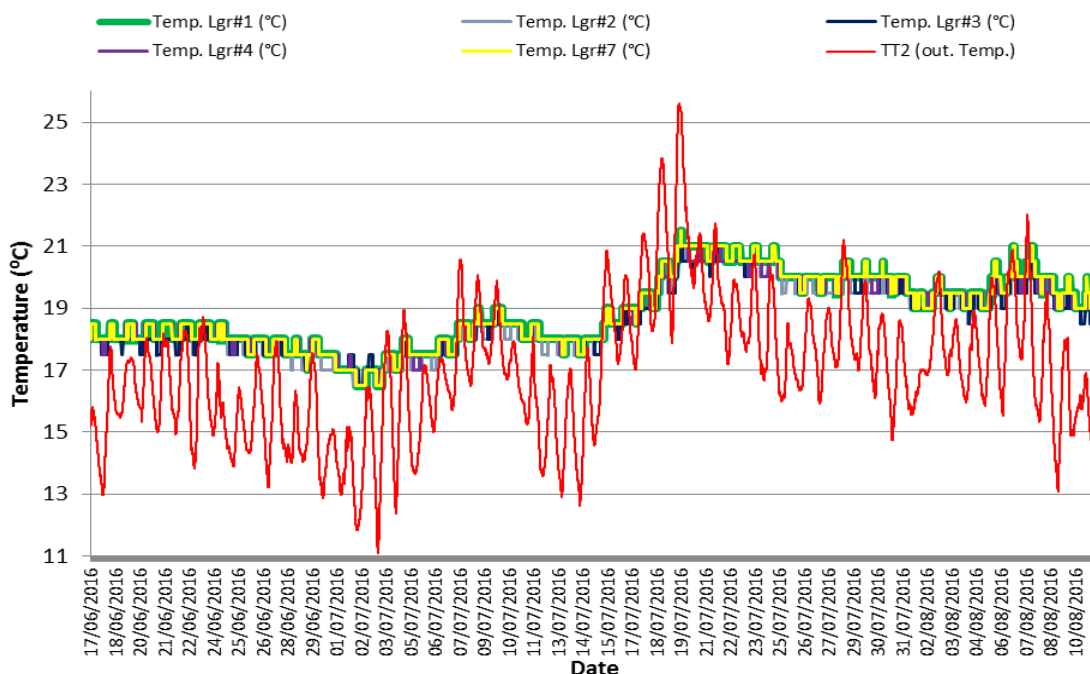

Figure 5.10 Logger readings for St. Canice's cathedral during summer 2016

In summary, therefore, it can be observed that with regard to temperature fluctuations, these two cathedrals, whilst they have many similarities, have largely, for usage and cost reasons, adopted very different heating regimes which have produced quite different T profiles within the buildings.

Relative Humidity

Whilst T readings were being taken every five minutes in both cathedrals, so also were RH readings. St. Patrick's RH readings for the winter are shown in Figure 5.11 and in Appendix 1.

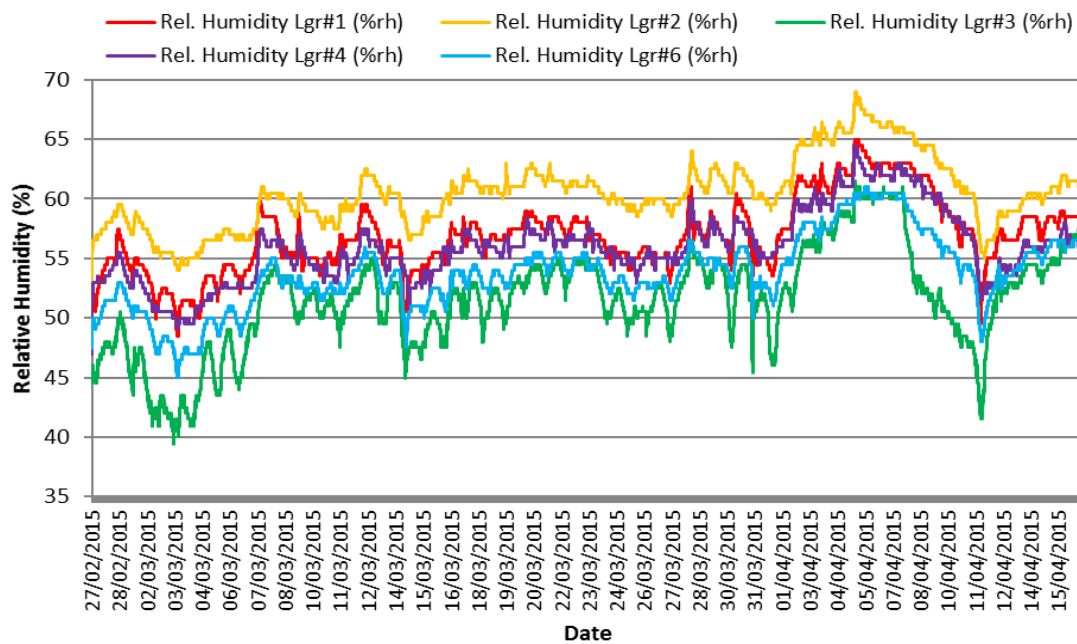

Figure 5.11 Logger readings for RH in St. Patrick's Cathedral, Dublin

Note that in St. Patrick's cathedral there is a drop in the RH readings when the T is elevated (Figure 5.11) as expected. The trend for each logger throughout the building is fairly uniform. The maximum differences between the readings are circa 15%. Logger 2, which was situated in the Lady Chapel at the East end of the building follows the general trend but is consistently slightly higher than the other loggers, but it also displays a consistently lower T than the other loggers. This is because it was placed on a South wall and hence received no direct sunlight coming through the stained-glass windows on that side. This lower T would explain the slightly higher RH for a similar moisture content in the air. An average figure of circa 55% for all the loggers would not adversely affect the building or its contents.

The Society of British Organ Builders recommends a RH of between 45% and 75%, (IBO, 2003) as being ideal for pipe organs and the figures for St. Patrick's generally fall within these limits. Logger 4 was deliberately placed in the organ loft at a height of 6 metres above floor level but the figures even at that elevated height are consistent with the other loggers which implies little stratification. Unfortunately, for reasons already explained, accurate outside RH readings for this cathedral are not available but based on the results produced for T, one would not expect the inside RH readings, during the winter, to follow those of the outside.

St. Patrick's cathedral holds, internally, several hygroscopic items including flags, which are very susceptible to changes in RH and T but the range of RH measured should not adversely affect these items (Camuffo, 2007). There are also many wooden items such as pews and kneelers inside the cathedral but many of the latter are varnished and the former are very old and have almost certainly adjusted to the present heating regime.

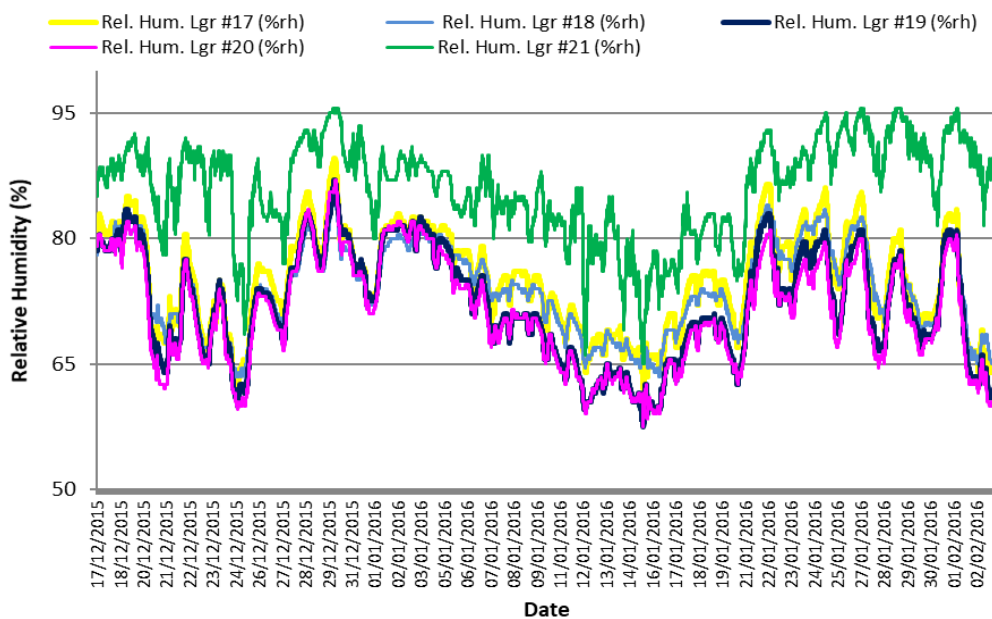

Figure 5.12 RH readings for St. Canice’s cathedral, winter

In contrast, Figure 5.12 shows the RH readings for St. Canice’s in the winter. Although the trend for the loggers seems to follow each other, the readings are much higher than in St. Patrick’s, being between 60% and 90%. The spikes in the external RH readings are because it rained on those days. The TinyTag was located in the porch of the cathedral which is open at all times to the elements, but the logger has produced some erroneous figures since an external RH of around 18% is most unlikely. At the higher end of these internal RH figures, this amount of moisture in the air would adversely affect the building and its contents. If the outside RH readings, which are also shown in Figure 5.13 for the summer data are compared with the inside RH readings, the inside mirrors the outside. Logger 21 was situated in the Eastern transept (this cathedral, unusually, is not orientated East to West) (See Appendix 15.1B). This is near to the office area and an unheated part of the cathedral, namely the choir room. This may explain the higher than usual RH readings for this logger, because being unheated, the choir room has a lower T and thus higher RH than the other areas of the building.

The RH figures for the summer for this cathedral are shown in Figure 5.13 and a clear connection between the outside and inside RH readings can be seen in the absence of any artificial heating. As with the T readings in this cathedral, the inside RH mirrors the outside RH readings but with much smaller, but noticeable, daily fluctuations, indicating infiltration/exfiltration of moisture over time through the fabric of the building. These very high RH summer readings are well outside the acceptable levels for both conservation and preservation and will be damaging to both the building and its contents.

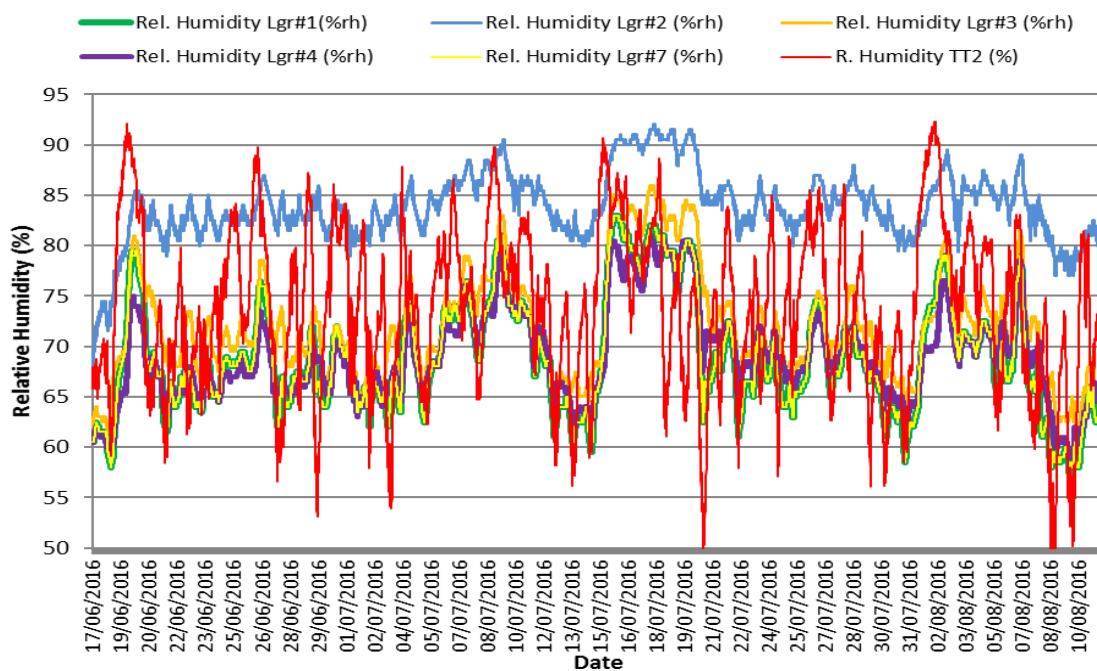

Figure 5.13 RH readings for St. Canice's Cathedral, summer

In summary, the two similar cathedrals have followed different heating regimes which have produced very different T and RH profiles. St. Patrick's, by keeping the heating on constantly during the winter, has produced an internal atmospheric environment which is largely independent of the outside environment. Had St. Patrick's been monitored in the summer it is most likely that the internal environment, as in St. Canice's, would have broadly mirrored the outside environment. This is because St. Patrick's, like many cathedrals, is likely to have a pervious envelope which allows egress and ingress of air to and from the outside. However, in the winter, due to the heating regime, this infiltration is masked.

St. Canice's on the other hand, with intermittent heating, has produced an internal environment which follows the external environment more closely in both summer and winter. Given the similarities of their age and construction it is probably the artificial heating and infiltration which produces this difference between the two buildings. It is likely to be expensive for St. Patrick's to keep the ambient T at around 18°C and this would be beyond the financial means of most cathedrals. By keeping the ambient T so high the problems of stratification and inversion, seem to have been avoided and both of these could have had serious consequences for the pipe organ which is situated some 6 meters from ground level. High level readings were not taken in St. Canice's, but it is possible that the T readings at the ceiling height are greater than those at logger height, which was about 2 meters above floor level. However, Corcoran (2010), who carried out research on the organ in St. Patrick's cathedral in Dublin, found no evidence in that cathedral of stratification with or without the heat being on.

Given the limitations caused by the locations and small numbers of loggers available, it is clear that St. Patrick's, at considerable cost, maintains an acceptable level of thermal comfort whilst St.

Canice's does not. With regard to the conservation of the buildings and their contents, St. Patrick's has the advantage in that it maintains a stable internal environment even if the T readings tend to be high with subsequently low RH readings. St. Canice's RH figures on a number of occasions exceeded 80%RH which would be damaging to the building and its contents. In particular the summer readings are well outside the accepted normal readings and will be damaging to the building and its contents.

St. Anne's Cathedral, Belfast and Galway Cathedral

Two other cathedrals within this size group, namely The Cathedral Church of Our Lady Assumed into Heaven and St. Nicholas, Galway (RC) which was completed in 1965 and St. Anne's (CI) cathedral in Belfast which was completed in 1981, are not dissimilar in age and size being 44,000 and 37,000m³ respectively but they too operate very different heating systems. St. Anne's was monitored between 12 November 2015 and 11 December 2015 and Galway from 13 March 2015 and 17 April 2015. St. Anne's relies on high level radiant electric heaters whilst Galway cathedral has seven condensing gas boilers operating an underfloor heating system. St. Anne's uses such a system because of the low number of visitors and the low numbers generally attending services. Both cathedrals are traditionally built. Galway has a tower, but St. Anne's has a spire because part of St. Anne's is built on top of a river and the ground would not take the weight of a spire or tower. Both cathedrals operate shops, Galway being in a separate room off the nave and St. Anne's being part of the reception desk in the nave. Both cathedrals have valuable pipe organs which are used regularly. St. Anne's contains several valuable hygroscopic items, principally flags, and these are referred to later. Galway has many painted wall and ceiling coverings some of which can be seen in Figure 5.14.

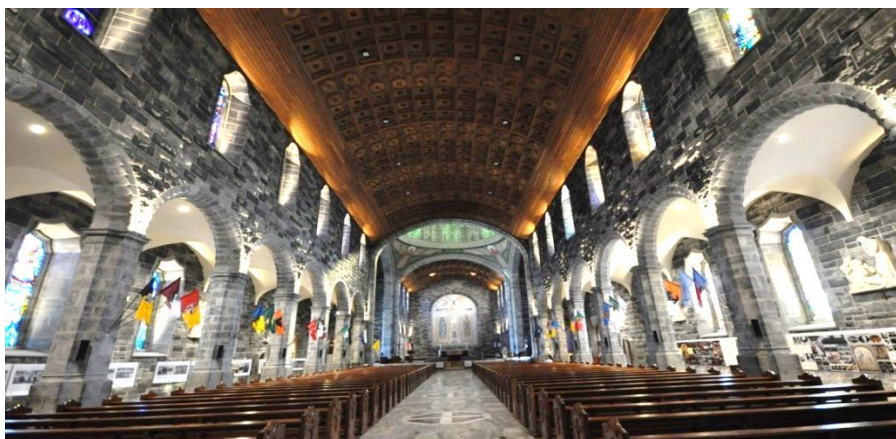

Figure 5.14 Cathedral of Our Lady Assumed into Heaven and St. Nicholas, Galway

Two problems were encountered in Galway; the first was that the manufacturers of the TinyTag equipment did not specify that the equipment should not be exposed to direct sunlight, which it was, and this resulted in intermittently high T readings which were obviously not accurate. Hence the outside T and RH readings for Galway cathedral had to be discarded. This was the same problem encountered in St. Patrick's cathedral and once the issue was discovered it was not repeated. A simple solution was found by placing the TinyTags inside a ventilated plastic container.

This defect was investigated by testing one TinyTag placed in a ventilated plastic container beside another which was not and both were exposed to direct sunshine and rain. The exposed TinyTag recorded readings in excess of 10°C higher than the protected TinyTag with appropriately lowered RH readings. This excess reading however was not consistent and it was not accurate enough to simply reduce all the readings by 10°C and then use them which is why the readings were not used.

The second problem was that in Galway one data logger was inadvertently removed by the cathedral staff towards the end of the monitoring period and was not retrieved until much later which means that some of the data towards the end of the monitored period was not valid for that logger, but it is obvious, from the data, when this was so.

In general, the cathedral manager in Galway is very conscious of the building's energy costs and, in recent years, insulation has been inserted into the area between the ceiling and the roof using loose beaded insulation material which was blown in from ground level. This insulating material was selected as it was believed to be the most suitable to fill in all the various crevices within the very large roof area. The cathedral heating system was also recently (2014) converted from oil to gas, partly because of fears of an oil leak from the oil storage tanks which were situated close to a nearby river which runs beside and around the building. The oil storage tanks were in an enclosed pit at the east end of the cathedral and this area now contains the gas storage tank.

The position which the loggers and TinyTag were installed in Galway Cathedral is shown in Figure 5.15 and Appendix 4.

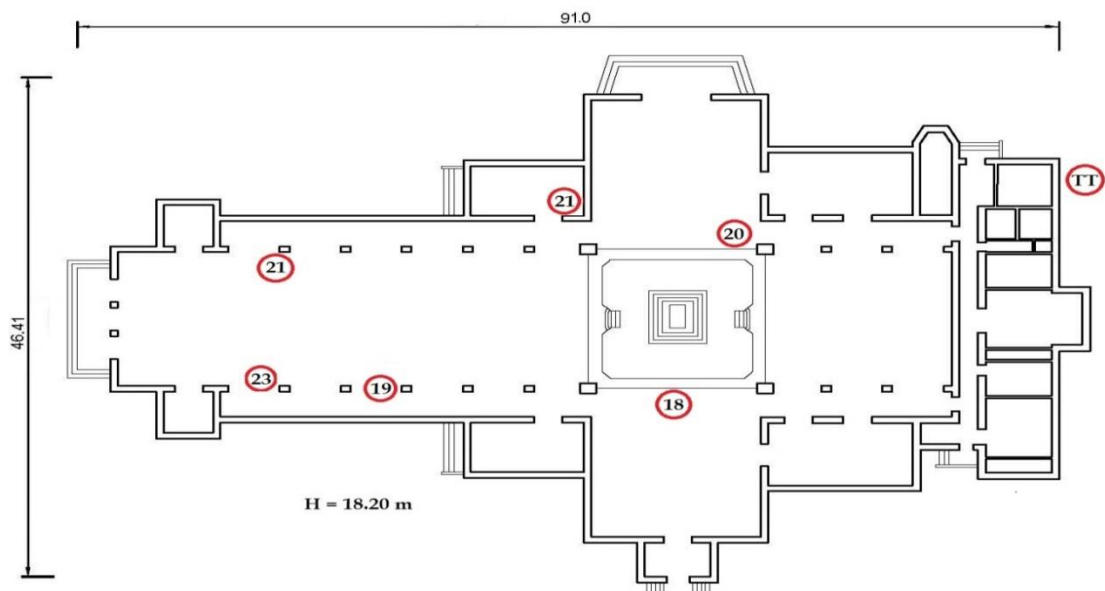

Figure 5.15 - Floor plan with loggers and TinyTag location of Galway's Cathedral.

Temperature

Figure 5.16 shows the T readings from the loggers in Galway cathedral and it is noted that the four loggers (and Logger 22, up until the time that it was inadvertently moved), are consistent and quite

different in profile compared to the previous two cases. This implies a relatively even spread of warm air throughout the building during the monitored period.

The general rise in T towards the end of the monitoring period was because of the Christian festival of Easter being at this period when there would have been a marked increase in the number of services and in the numbers attending services.

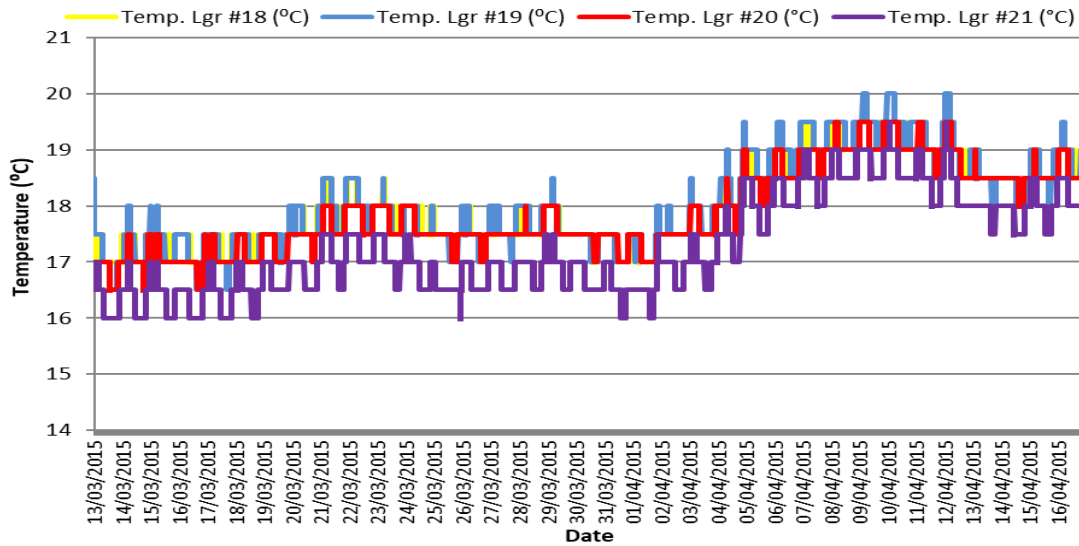

Figure 5.16 T readings for Galway cathedral, Galway

The cathedral achieved a relatively high ambient T of circa 17°C. The stability of the rate per hour readings (see Figure 5.17) and the T readings in Galway, show the positive effect which the roof insulation has in this cathedral. The readings are very consistent, especially considering the size of the building. The gaps in the graph indicate that no temperature changes greater than 0.5°C/hr occurred on that day.

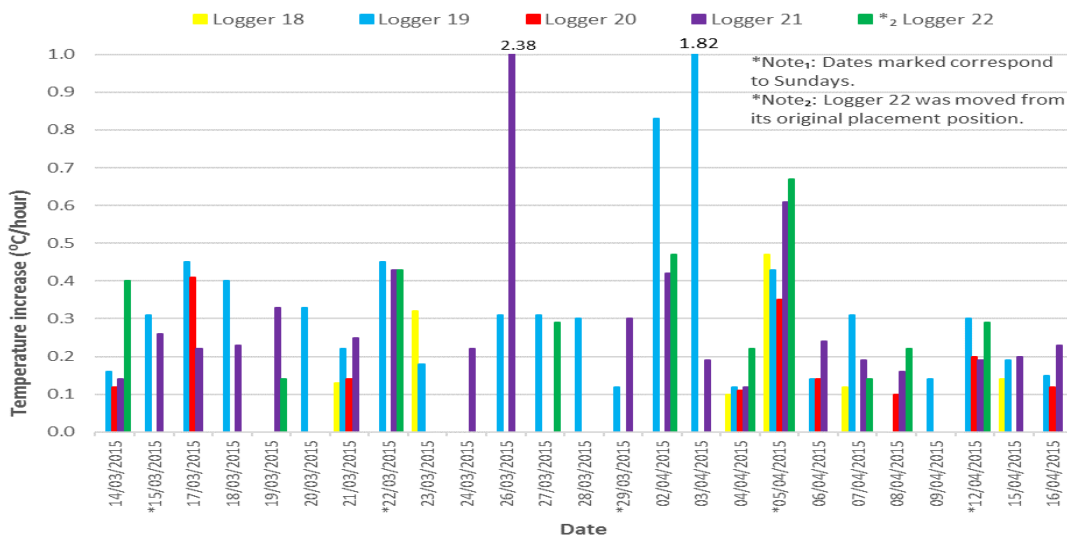

Figure 5.17 - Rate of temperature increase per hour in Galway cathedral

The rate of temperature increase is circa 0.2°C/hr, similar to St. Patrick’s cathedral in Dublin. The reason for such a low rate of increase per hour is due to the heating being on continually during the

day, the ambient T is always high at between 17 and 18°C, therefore the boilers are easily able to maintain a constant T throughout the building. This behavior is similar to St. Patrick's cathedral in Dublin.

The logger's positions for St. Anne's cathedral can be observed in Figure 5.18.

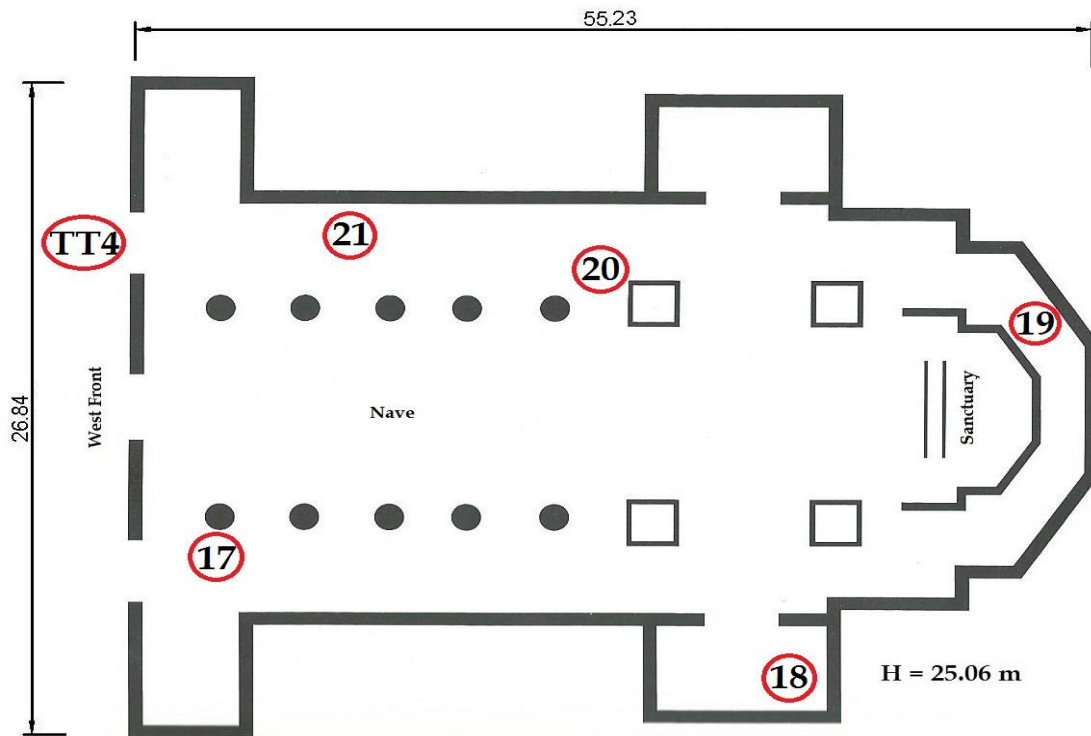

Figure 5.18 - Floor plan with loggers and TinyTag locations installed in St. Anne's Cathedral, Belfast

This cathedral was monitored from 12 November 2015 until 11 December 2015 and the T readings from the data loggers and the TinyTag can be found in Figure 5.19.

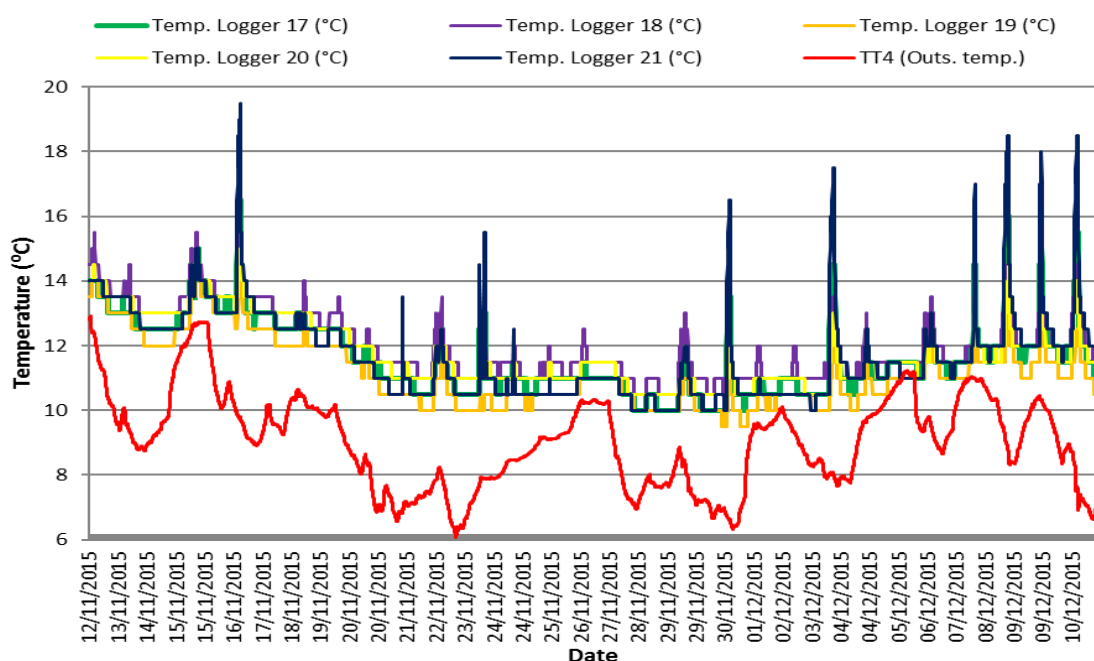

Figure 5.19 Loggers' and TinyTag T readings for St. Anne's cathedral, Belfast

Except for logger 21, the readings for the loggers are quite consistent and the inside T (ranging from 10°C to 14°C) is remarkably stable diurnally. The inside T generally follows the outside T, as can be observed indicated by the TinyTag readings in the graph. The reason for this low T range with spikes is the type of heating used in the cathedral, namely radiant electric heater. (See Figure 5.20). These are only switched on for services and clearly do not heat up the building. The peaks can be explained as being where the loggers were exposed to the radiant heat coming from the heaters. The sharp fall in the T readings is because the radiant heaters are heating the air and not the building and so thermal mass is much less relevant.

It was difficult to find suitable locations for the loggers in this cathedral until small metal brackets were discovered at a height of about 3 metres which had been used previously for internal monitoring of the cathedral. Whilst higher than desirable, these were permanently fixed brackets which held the loggers securely and out of reach and were therefore used for this research.

St. Anne's has a much lower average internal ambient T than Galway at around 11°C and this is because the radiant heaters are only turned on for services despite the cathedral being open all day. The external T dropped to just over 6°C on the 23 November but the inside T on the same date was around 11°C. The outside T can vary by up to 3 or 4°C in one day whilst the inside T varies by only 1-1.5°C over the same period.



Figure 5.20 Electric radiant heaters switched on in St. Anne's cathedral

The thermal mass of this large building is working to stabilise the internal T readings, more so than background, for example in the case of St. Canice's cathedral in Kilkenny which has a completely different heating regime which actually heats up the building through regular heating. St. Anne's cathedral has a separate glassed off area for low attendance services, as shown in Figure 5.21.



Figure 5.21 - Inside of the glassed off area in St. Anne's cathedral, Belfast

This allows a small area of the cathedral to be heated using three wall mounted electric infra-red heaters for occasional services.

The high peak readings for logger 21 were as a result of this logger being placed near to the shop area which has additionally two portable heaters, namely an electric oil filled radiator and a hot air blower. These units are moved around at the wish of the shop staff and one or both must have come close enough to the logger to affect its readings.

The rate per hour increase for T for St. Anne's is shown in Figure 5.22. Unlike the previous cathedrals depicted, the rates differ widely amongst the loggers, depending on how far the loggers are situated from a radiant heater. The average is greater than 1°C/hr with many peaks above 4°C/hr, showing instantaneous heat close to the radiant heaters.

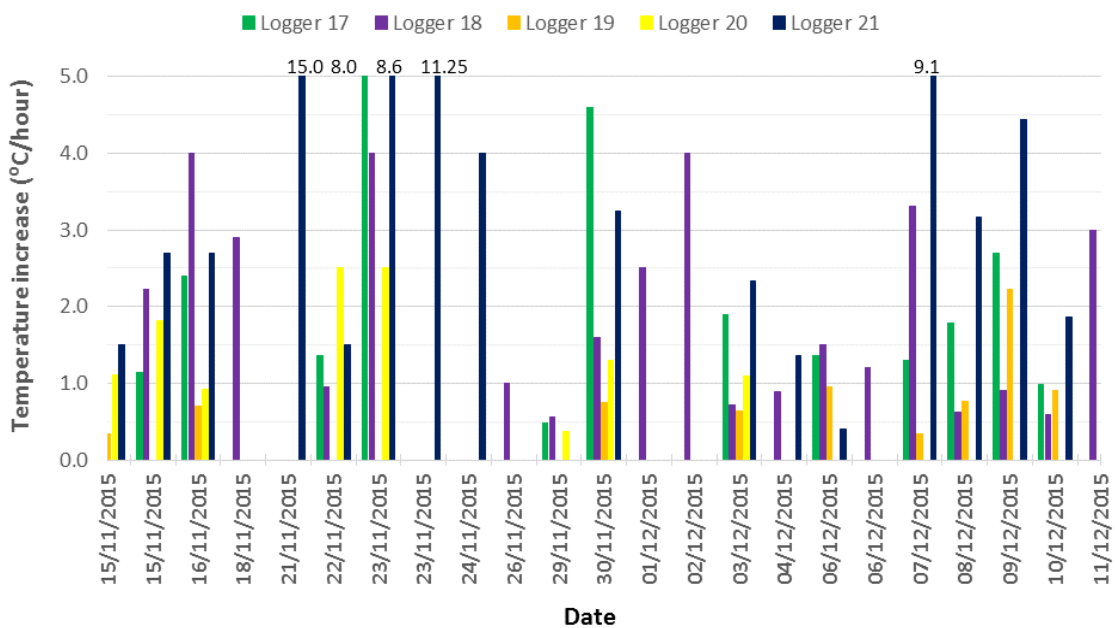

Figure 5.22 Rate of temperature increase per hour in St. Anne's cathedral, Belfast

St. Anne' cathedral showed a number of the typical characteristics of radiantly heated buildings, namely long periods of no increase in ambient T and reasonable uniformity of the spread of low T readings throughout the building with a very rapid heating when switched on and equally rapid cooling when switched off. This means there is a very short heating period, the walls are not being heated and thus dissipation is fast. The inside T did not follow the outside T to the level expected because of low infiltration from the outside helped by the automatic doors at the West end of the building.

Moisture

The combined RH readings for all of the loggers in Galway cathedral are illustrated in Figure 5.23. The range is from circa 46% to a maximum of 70% although the majority of the loggers recorded RH readings are in the range circa 50% to 65% which is quite a narrow band for such a large volume building with large changes outside.

On average, the RH values are lower and more stable due to the higher and more stable T. The lower RH readings at the end of the recording period corresponded with the Easter period and reflected the higher T readings in the same period. Logger 22 recorded higher RH readings than the other loggers but also lower T readings as it was situated in a side chapel which was infrequently used.

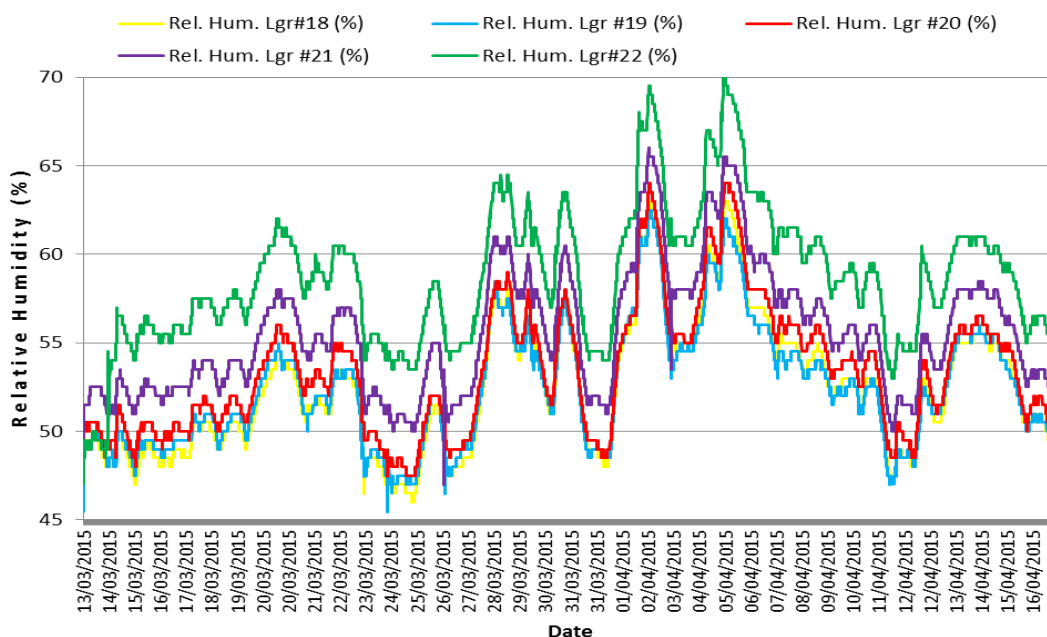

Figure 5.23 Loggers' readings on relative humidity in Cathedral of Our Lady Assumed into Heaven, Galway

With an average of around 55% RH, this would not adversely affect the building or its contents. The loggers follow each other closely which shows that changes in RH levels diffuse quickly throughout the building although the loggers themselves record slightly different levels, depending on their locations and local temperatures.

The RH readings for St. Anne’s cathedral are shown in Figure 5.24 and the variations appear quite different to Galway cathedral. The range is from circa 55% to circa 85% which is a larger range than Galway but with intermittent heat, which does not heat up the fabric of the building, this is expected. Logger 21 is the logger nearest to the shop area and, as already highlighted, was affected by mobile artificial heat in that area and hence low troughs exist corresponding to spikes in Figure 5.19. Overall, Figure 5.24 is a good example of the two principal contributors to changes in RH: when T rises RH drops and vice versa, just as in logger 21 spikes, and if RH is higher outside, additional moisture will infiltrate the cathedral pushing up RH independently of T (such as from 13-15 November and vice versa).

The rises and falls are generally much sharper than in Galway with a difference of over 25% in four days. These large swings could be damaging to any hygroscopic materials in the buildings such as flags, books and wooden furniture as well as to the pipe organ.

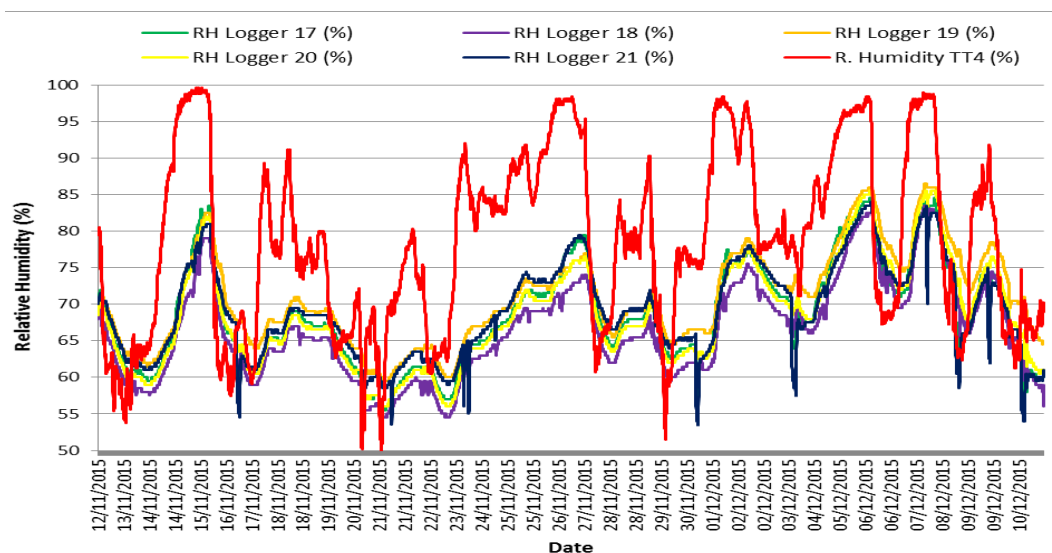

Figure 5.24 Relative Humidity levels (%) inside and outside in St. Anne's cathedral

The relatively high RH readings are because the building is not being heated up by the intermittent use of the radiant heaters. The internal RH readings follow the external TinyTag readings closely (though outside RH readings can vary as much as from 50% to 100%), which is to be expected in a building with a permeable envelope. St. Anne’s cathedral has several valuable artefacts, principally flags, which are very susceptible to changes in T and RH as well as a large and well used pipe organ, so stability and range of both T and RH are important in this building.

These two cathedrals, namely Galway and Belfast, have adopted completely different heating solutions, largely based on usage. Both cathedrals are open every day but the daily services in St. Anne’s attract much smaller numbers than those attending Galway. For instance, Galway cathedral will have an average Mass attendance on Saturday nights of approximately 800 and on Sundays of between 400 to 600 worshippers. In contrast St. Anne’s will attract just over 100 people on average

for its main service on a Sunday. Like most Church of Ireland cathedrals, it has no regular service on a Saturday evening. St. Anne's does however attract some 50,000 tourist visitors a year. The figure for Galway for such visitors is not known because Galway, like all RC cathedrals, does not charge for entry and so no register exists recording the visitor numbers.

It is known that radiant heaters often fail to provide adequate levels of thermal comfort and the readings from St. Anne's clearly show this. More loggers would have been ideal and especially if they could have been located in the nave but even with these limitations it is obvious that this cathedral fails to provide adequate levels of thermal comfort to its users. Galway cathedral, which is well insulated, does manage to provide an adequate level of thermal comfort although again, more loggers, placed in the nave, would have been a better solution. With RH readings between 50% and 65% Galway cathedral is within acceptable levels for conservation and preservation whilst the readings for St. Anne's cathedral which are between 65% to 85%, would not.

St. Patrick's Cathedral, Armagh

The last of the monitored cathedrals in the very large category is St. Patrick's (RC) cathedral, Armagh. The monitoring in this cathedral was carried out between 25 October 2016 and 25 November 2016. This cathedral has underfloor heating backed up by an LPHW system powered by two gas fired boilers. However, the underfloor heating is not used, to save money.

It was almost certainly the intention of the original design that the underfloor system would run continuously at a conservation level of heating and this would then be augmented for services by the LPHW system. However without access to the original specification, which was not possible, this can only be educated conjecture. The building itself is traditionally built, with solid stone walls, a stone and wooden floor, a painted ceiling, as shown in Figure 5.25 and a slate roof.

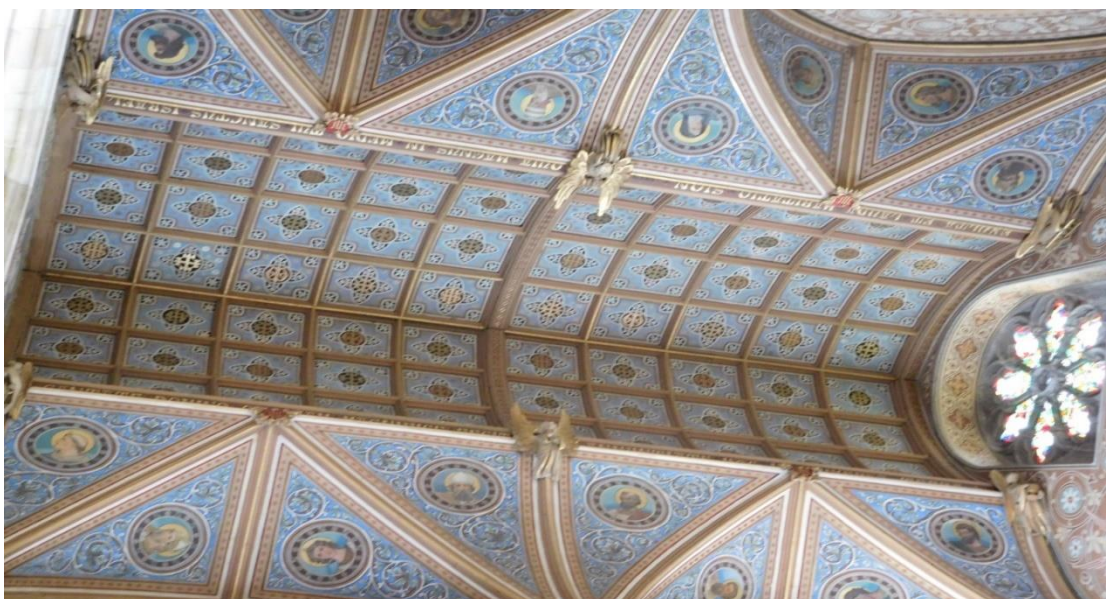

Figure 5.25 St. Patrick's (RC) cathedral's ceiling (Armagh)

The internal walls of the cathedral have many fine paintings on them. It is not known if there is any insulation between the ceiling and the roof. The windows are single glazed with external storm glazing fitted. The building contains a monetarily and intrinsically valuable pipe organ which is situated over the West door. The cathedral is situated in a very exposed position on top of a hill and is not protected from the elements by any surrounding buildings even though it is not far from the city centre. There is a shop within the main body of the building situated near to the West door but it is contained in a separate enclosed area and is accessed from a door off the nave.

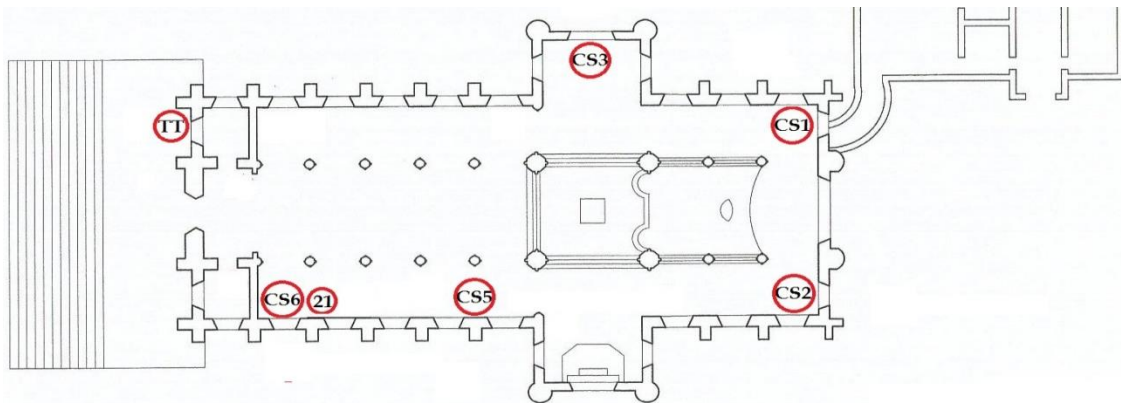

Figure 5.26 - Floor plan Armagh (RC) winter

Further details on the location of the inside and outside loggers during the winter in this cathedral are shown in Appendix 5B.

Temperature

The readings from the loggers, amalgamated with the external T readings (TinyTag) during the winter monitoring period are illustrated in Figure 5.27. Regrettably, the battery in Logger CS3 failed hence, the figures for this logger were not included.

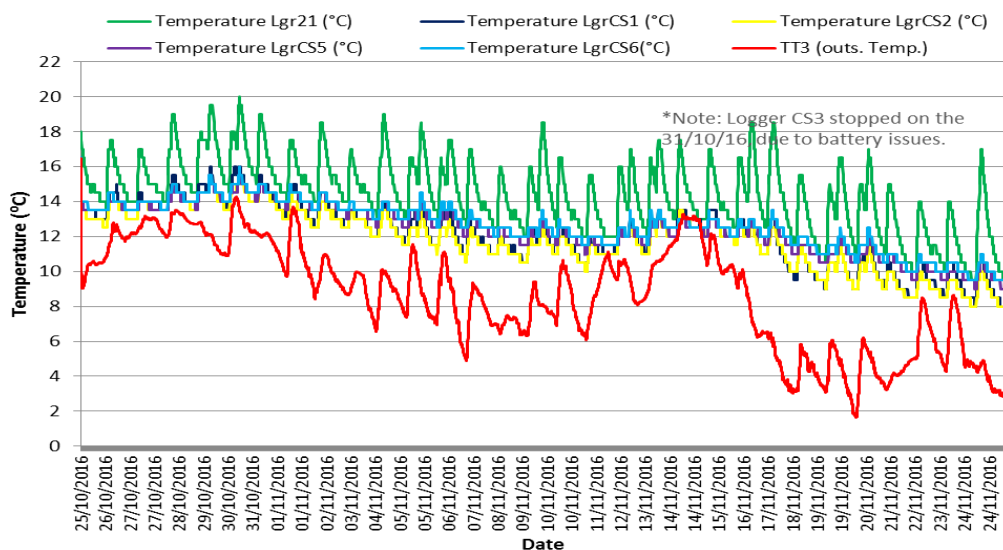

Figure 5.27 T readings in St. Patrick's cathedral, Armagh (RC)

Apart from Logger 21, which will be discussed shortly, the remaining loggers displayed an even spread of air temperature throughout the cathedral but at a low average T ranging from 16 down to 10°C, over the monitored period as the external T generally drops. The diurnal and nocturnal variances, under a daily heating regime can clearly be seen. It is also noted that the internal T broadly replicates the external T in that when the external T slowly decreases on average over the monitored period, so does the internal T. This is because no evidence was found of any thermostats or other heating controls inside the building. The heating is set to come on and go off at particular times each day, regardless of the inside or outside T, so if the outside T drops, the boilers are not programmed to stay on longer to compensate for this and vice versa. This will lead to insufficient heat for thermal comfort should there be a prolonged period of colder weather. For example, typically during the week of 17-20th November the average internal T had dropped to 10°C from 14°C weeks earlier. The building was designed with underfloor heating which ideally would be left on at a low T all the time, backed up by an LPHW system for services. By not using the underfloor heating the cathedral management has altered the designed heating regime intent which will save money but has resulted in unacceptably low internal T readings at certain times particularly during Mass in late November.

A more detailed analysis of logger 21 can be found in Figure 5.28 which shows the readings particularly during Mass in late November for a short period from 31st October to 2nd November 2016 and from which the effects of the intermittent LPHW heating system in this cathedral, on the internal thermal environment can be clearly observed.

The rate increase in T is shown in Figure 5.28 and shows an average increase per hour of 1°C which is quite high and is explained by a low initial T along with heating type, size of the building, air losses, power of the boiler and radiator, and, as in this case the difference in T. This is why the rate of increase in this cathedral is five times that for St. Patrick's Dublin.

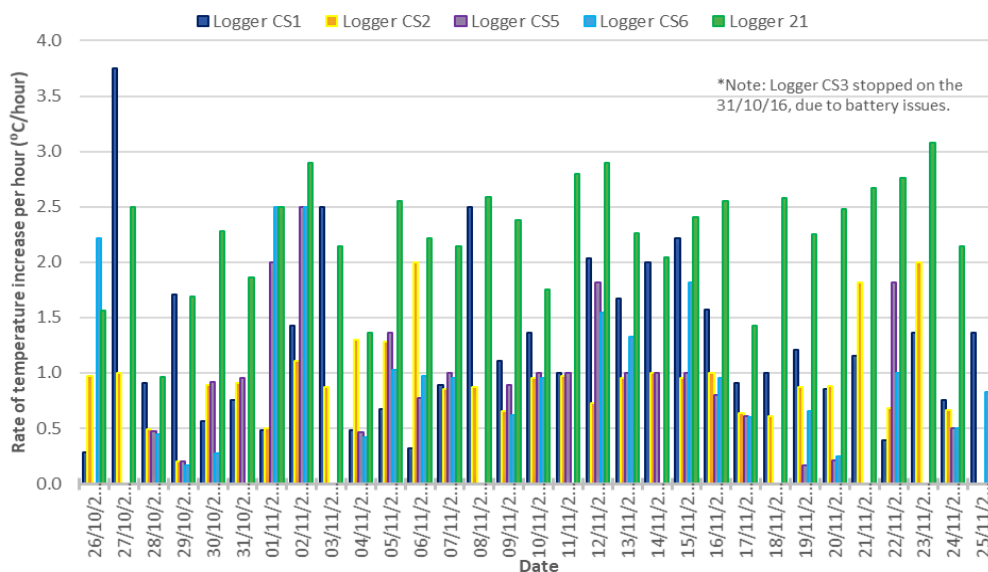

Figure 5.28 Rate of temperature increase per hour in St. Patrick's Cathedral, Armagh (RC)

Therefore, to elevate the average temperature from 10°C to, say 15°C, would take about 5 hours and a considerable amount of thermal energy.

Loggers CS1, CS2, CS5 and CS6 showed very similar patterns to each other with a general falling off in T towards the end of the recording period. The minor differences between the loggers are accounted for by their locations around the building and their proximity to things such as outside doors and radiators. The different readings for logger 21 were caused by this logger being deliberately placed above a radiator so that it would be possible to tell when the heat was coming on and off and this is shown in Figure 5.22. It is useful to note from Logger 21 that on many days the heating is switched on for two periods, presumably to accommodate attendees at Mass.

This building was also monitored in the summer and the logger placements within the building are shown in Appendix 5.

The consolidated readings for the loggers and the TinyTag in the summer are shown in Figure 5.29. Whilst there are slightly different profiles for each logger, they are consistent with T readings of circa 16 to 18°C showing great nocturnal stability with no more than a 0.5°C change over many hours. Logger 21 shows a small number of sporadic high peaks, reaching 22°C on one occasion and this is because the logger may have been influenced by sunlight coming into the building from the opposite side to where the logger was placed.

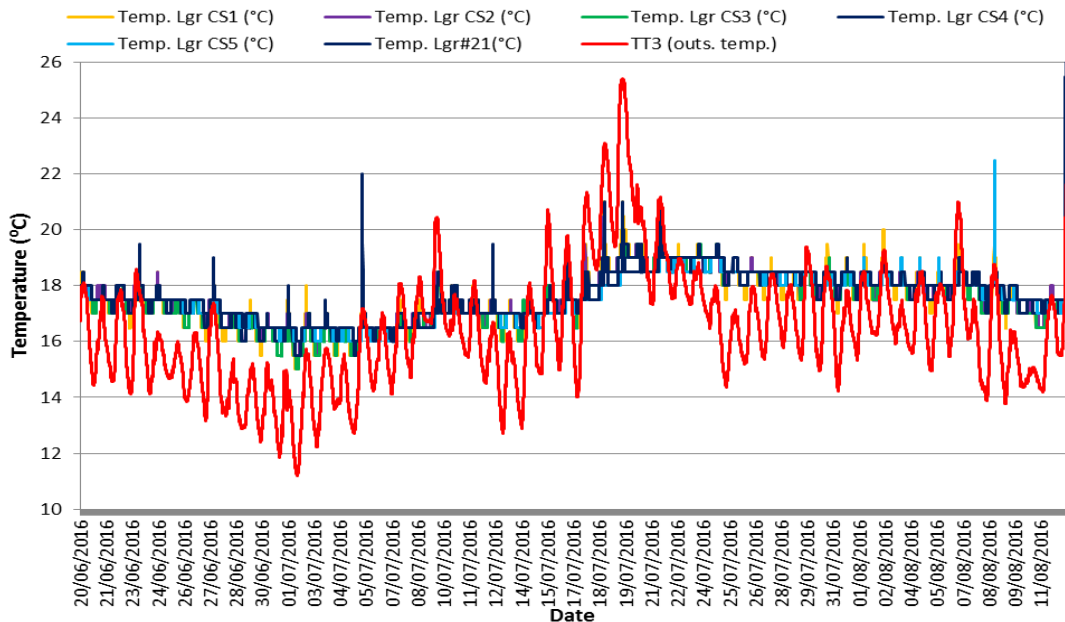

Figure 5.29 T readings indoors and outdoors in St. Patrick's Cathedral in Armagh (RC) during summer

The internal ambient T during the summer is circa 16°C which is high considering that the outside T was less than this for the first half of the monitoring period. The figures show that, as expected, the internal T is much more stable than the outside T and the inside T in the summer broadly mirrors the outside T. This is because of the thermal mass of the building which stabilises the inside T figures. The TinyTag shows a spread of readings from a low of 11.5°C to a high of just over 25°C whilst

internally the T range is only about 3°C over 6 weeks. This is similar to the other two cathedrals which were monitored in the summer, namely Christ Church cathedral in Dublin and St. Canice’s in Kilkenny, although the latter two cathedrals are hundreds of years older than St. Patrick’s although of similar size. This would imply that all three cathedrals, regardless of their age have very slow ingress and egress of heat and air and, maintain stable internal T readings during the summer and broadly gradually follow the average outside T readings, as shown in Figure 5.29.

Moisture

The winter RH composite graph is shown in Figure 5.30 and except for Logger 21, shows a high degree of uniformity. Whilst the internal RH readings are not as extreme as the external ones they do tend to mirror each other as observed previously. The general RH ranged from 45% up to circa 84% which is a large spread especially as it occurred only over a seven-day period. Such large fluctuations in RH could have adverse consequences for the building and its contents and is outside the recommended range for the optimal operation of a pipe organ, which this cathedral has. This implies a quite considerable infiltration as RH internally is strongly influenced by outside RH.

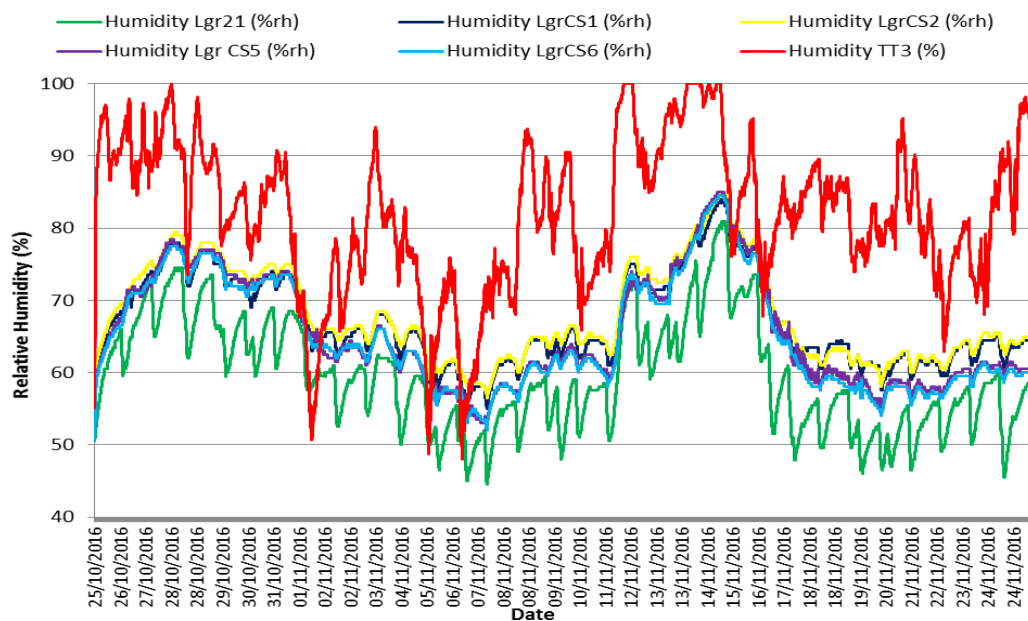

Figure 5.30 Inside and outside reading on Relative Humidity (RH%) in St. Patrick’s Cathedral, Armagh (RC)

If it was possible have more loggers and to have placed them in the nave where most people sit, then some of the limitations of the research would have been mitigated. However, it is clear from the readings that by not using the underfloor heating that the internal environment is too susceptible to changes in the outside environment and adequate levels of thermal comfort are not provided. However, the RH readings would suggest that this cathedral does provide an environment which is reasonably suited to conservation and preservation although the range which is between 55% and 85% will present problems as can be seen by the efflorescence around the windows.

5.1.2 Very Large Cathedrals not monitored

The remaining very large cathedrals which were not monitored are in Newry, Cobh, Monaghan and Limerick. The characteristics of these cathedrals are set out in Table 5.1. They are all Roman Catholic cathedrals and hence are open every day to the public. They are similar in size and age and yet two of the four have adopted quite different heating strategies. Cobh had an LPHW system but it was taken out as it was not performing to the level expected and it was replaced with an underfloor system during the last major renovation of the cathedral in the 1980s.

These buildings are very prominently located in their various areas and cater for substantial numbers of worshipers, with some in the region of a total of about 200,000 per year with daily services and usually with more than one per day. However, the number of services and the numbers attending those services do vary with one cathedral having approximately 160 services per year and another having over 800. It depends, presumably, on the size of the parish being served by the cathedral and the number of services will obviously have a direct impact on the cost of heating the buildings. The number of services held in each cathedral is discussed in Chapter 4.

A point to note is that Limerick (RC) cathedral is the only cathedral in Ireland which has a copper roof and this was completely replaced, again in copper, as part of a substantial refurbishment of the whole building which was completed in 2003. Installing a copper roof is an interesting and perhaps challenging solution since copper is known to have a very high U value or transmittance value of approximately $380\text{kW/m}^2/\text{hr}$ (ISO10456) which shows that heat is very easily transmitted through this material. The U value for instance of a typical single glazed window, is $5.7\text{kW/m}^2/\text{hr}$ (McMillan, 1983). The space between the ceiling and the roof would have to be very well insulated to avoid substantial heat loss through the roof. The cathedral manager did not know if this area was insulated.

5.1.3 Key findings for very large cathedrals

- In the case of St. Patrick's and St. Canice's cathedrals it can be observed that two similar cathedrals have, for operational reasons, adopted completely different heating regimes. Figure 5.4 shows the stability of temperature (T) within St. Patrick's cathedral caused by the continual heating during the winter months. This cathedral is able, at a cost, to create and maintain an artificial internal thermal environment, more or less independently from the external environment. On the other hand, with its intermittent heating regime, St. Canice's cathedral, in both summer and winter, as evidenced by Figure 5.5 and Figure 5.10, demonstrates that the internal environment is clearly influenced by the external environment, especially with regard to T, but also with regard to RH. To conclude, both cathedrals have arrived at different solutions to solve a common need, namely the heating of

the buildings so that they remain comfortable for occupants and therefore are used and relevant. The different solutions are a result of different circumstances based primarily around usage, cost and the ability to pay.

- Galway cathedral and St. Anne's cathedral in Belfast were compared due to similarities in age, size and construction. However, both have again, for operational reasons, adopted completely different heating systems and regimes. Unfortunately, the TT readings for Galway were not, for reasons already stated, available, but the stability of the internal readings in that cathedral show that, like St. Patrick's cathedral in Dublin, they have managed to build a broadly stable internal environment, which is independent of the outside environment, by heating the building continuously during the heating season. In addition, the stable internal rate per hour increases in Galway cathedral together with the internal T and RH readings strongly suggest that the roof insulation, which is known to exist, is having a positive effect on the internal environment. St. Anne's, with its electric radiant heaters has a system which, with its much lower internal average T and with their low numbers of visitors, is suitable for them but the close proximity of some of the artefacts to the heaters should be a cause of concern. The various readings clearly confirm the intermittent effects of the radiant electric heaters used in this cathedral where the people, not the building fabric, are being kept at a comfortable T during services only which means that it generally has a much lower internal temperature than others when the heaters are off.
- Armagh Roman Catholic cathedral has, for financial reasons, decided not to use the underfloor heating which is installed. Instead they rely entirely on the LPHW system of radiators and pipes. The boilers are set to come on for a given amount of time each day, regardless of the outside environment. The effect of this, as is shown in Figure 5.29, is that when the outside T goes down significantly so does the inside T because the boilers do not have sufficient time to compensate. A longer period of cold weather would result in uncomfortably cold internal T readings with high RH readings which could cause damage to internal artefacts. Likewise, should there be an unseasonably warm spell during the winter the cathedral will heat up to possibly an uncomfortably high degree with this heating regime. The solution is to install a simple heating control system and set the internal T range to allow the boilers to compensate for this. By changing the heating system in this way Armagh cathedral has made itself more susceptible to the outside environment rather than less so.
- The details of the remaining four unmonitored very large cathedrals in this category, namely Newry, Cobh, Monaghan and Limerick are set out in Table 5.1. Three use gas and one oil and two have LPHW systems with one having HVAC and one underfloor heating. Their heating systems are as diverse as the buildings themselves because, as will be discussed later, there

is no evidence of knowledge sharing between the managers of these buildings and each has developed a system which, considering their own particular circumstances, seems to suit them.

- The overall conclusion from investigating these very large Irish cathedrals is that the diversity of installations is wide and the ways in which they are operated are very different and are strongly dependent on the usage demands and financial situation of each building. Empirical evidence has shown that cost and thermal comfort are the relevant issues for the managers of these buildings rather than conservation and preservation.
- Insulation, as found in Galway cathedral, does stabilise internal T and RH figures.
- Changing the design parameters, as in Armagh (RC) cathedral can have possibly unforeseen consequences which in the case of that cathedral resulted in internal T falling as external T fell even though the boilers are almost certainly large enough to prevent this.
- Usage is a very important input which has a large effect on the internal thermal environment of a cathedral. St. Anne's cathedral in Belfast uses electric radiant heaters because of relatively small numbers using the cathedral for services, even though it is open every day for visitors.
- Even when cathedrals seem similar in many respects, such as St. Patrick's in Dublin and Kilkenny (CI), differences in use (and financial resources in this case) result in very different internal thermal environments.
- The buildings are very diverse and no one heating solution suits them all.
- St. Patrick's cathedral should question why they need such a high ambient T when the cathedral is not being used for services.
- An artificial internal thermal environment can be created, at a cost, and be independent of the external environment.
- Stratification is limited in a constantly heated cathedral because the whole internal air volume remains heated.
- Radiant heaters can produce large swings in RH as in St. Anne's in Belfast.

5.2.1 Large Cathedrals

Large cathedrals are those categorised here as having an internal capacity of between 20,000m³ and 30,000m³. There are six cathedrals which fall into this category with all but one of them being owned by the Roman Catholic Church. The one exception is St. Mary's Church of Ireland cathedral in Limerick which is also, by many hundreds of years, the oldest cathedral in this group and one of the oldest cathedrals in Ireland. Four of the six cathedrals were monitored, namely those marked with an '*' in Table 5.2. Again, this is a high percentage of monitored cathedrals, but it was important to monitor a large percentage of these cathedrals because, like the very large ones, they represent a good cross section of the cathedrals in Ireland taking into account factor such as age, usage, location and size, amongst others. In addition, this group includes St. Mel's cathedral in Longford which was destroyed by fire in December 2009 and subsequently rebuilt and reopened in 2015 making it the most modern cathedral, certainly in Ireland, if not in Europe. It also has a completely up-to-date heating system which, in some ways, makes it a benchmark for other similar sized and utilised buildings. It can be observed (Table 5.2) that most of these cathedrals use LPHW heating systems while three of them also have an underfloor system as well. It is known that the design team involved in the rebuilding of St. Mel's cathedral did take an holistic approach to the building by examining its size, use, age, construction and all of the other relevant parameters before selecting the underfloor/LPHW model. Allowance was made in the case of this cathedral for future linking to a district heating system and for the installation of solar thermal heating.

The large monitored cathedrals have a number of unique features as follows:

Dublin (RC)	Situation, importance, usage, age of heating system.
Limerick (CI)	Age, location, usage.
Killarney (RC)	Heating system, location, usage.
Longford (RC)	Age, heating system, insulation, BMS.

The RC cathedrals in this group represent part of the group which were built between approximately 1799 and 1900 which implies that when the RC church was no longer repressed by the British crown it tended to build larger rather than smaller cathedrals which, considering that at the time some 98% of the population was Roman Catholic, is not surprising. The fact that two of these cathedrals use oil rather than gas, is because mains gas is not available at those sites and they do not have the space for the installation of large gas storage tanks.

Table 5.2 - Large cathedrals (between 20,000 m³ and 30,000 m³), showing age, heating type and fuel used.

City	Name	Size (m ³) Approx.	Age	Heating type	Fuel
Mullingar	Christ The King (RC)	29,000	1939	LPHW	Oil
Dublin*	Pro Cathedral (RC)	25,000	1825	LPHW	Gas
Derry	St. Eugene's (RC)	23,000	1873	LPHW	Gas
Limerick*	St. Mary's (CI)	22,500	1195	Underfloor	Gas
Killarney*	Assumption of the Blessed Virgin Mary (RC)	22,500	1855	Underfloor & LPHW	Oil
Longford*	St. Mel's (RC)	22,500	1856 & 2015	Underfloor & LPHW	Gas

*Note: monitored

St. Mary's Pro Cathedral, Dublin

The reason for highlighting this RC cathedral is because of its unusual shape, its city centre location, its very high usage and its importance to the city of Dublin. This cathedral is traditionally built with solid stone walls, single glazed windows and a tiled roof with painted internal ceiling. It is not known if there is any insulation in the building, but it is understood to be most unlikely. It is a relatively old RC cathedral with a gas fired single boiler, of unknown age or make, installed in a basement of the building. It is a building with a high footfall, being open every day and in constant use. This usage pattern is quite typical of city centre, Roman Catholic cathedrals with a steady flow of people moving in and out of the building throughout the day. The building is surrounded on two sides by other buildings which shelter it from strong winds. A new light rail system is being installed in the city centre of Dublin and part of it will run outside the front of the cathedral. This may impact on the energy use of the building, if it leads to increased numbers using the building.

Temperature

The locations of the internal and external loggers that monitored the temperatures in the Pro Cathedral can be observed in Figure 5.31 and Appendix 6.

Unfortunately, no suitable outside location could be found for the TinyTag. This was a problem encountered in a number of cathedrals as even if suitable locations could be found, where the TinyTag could be left without being removed, a ladder would usually be required in order to place the unit and these were not usually available. Further, using a ladder at such elevated heights raises significant health and safety issues.

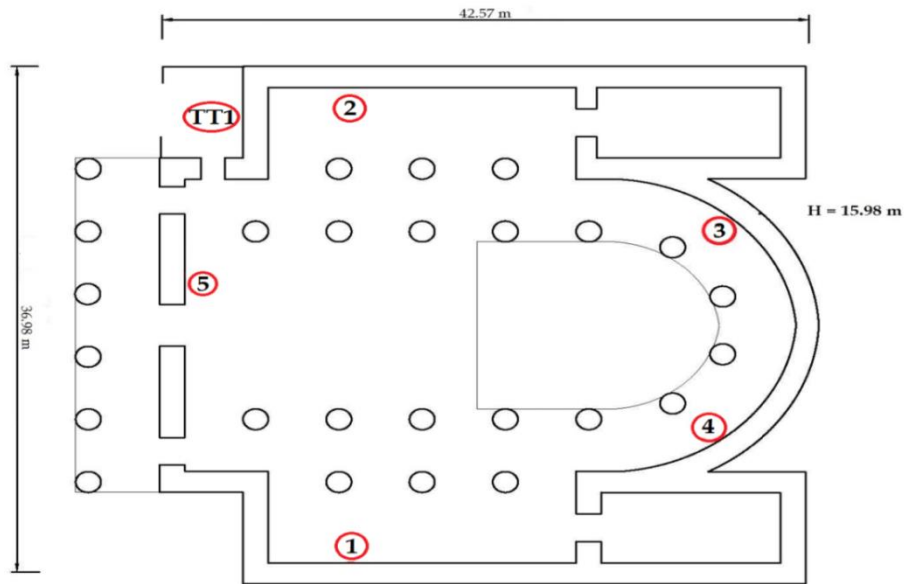

Figure 5.31 - Floor plan St. Mary's Pro Cathedral, Dublin

The TinyTag was placed just inside a large wooden door which leads to the outside in an unheated part of the cathedral, but it is accepted that this was far from ideal. Access to the roof of the building was not allowed. The readings from the loggers and the TinyTag are shown in Figure 5.32.

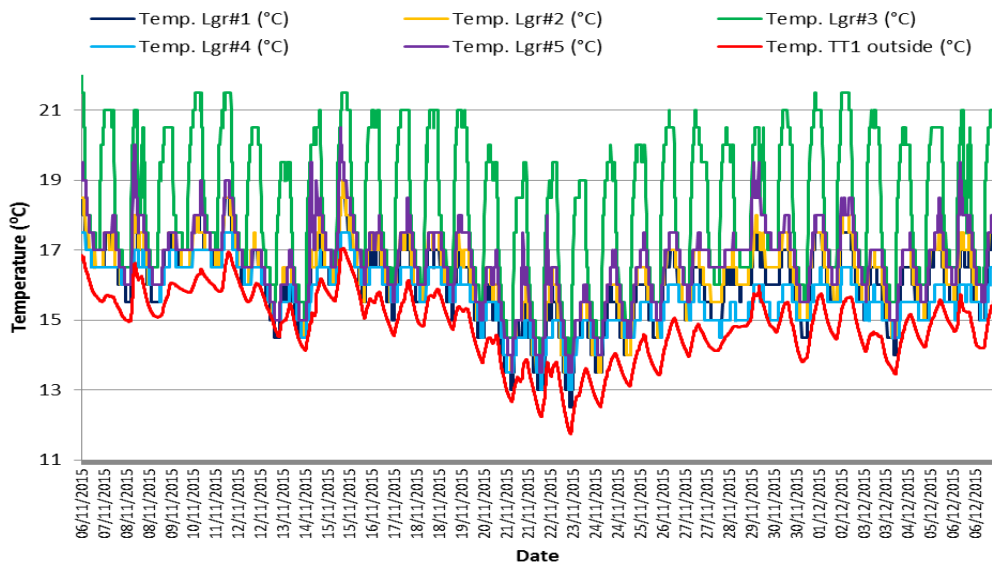

Figure 5.32 - Temperature readings in St. Mary's Pro Cathedral, Dublin

Dealing firstly with the obvious anomaly of Logger 3 which peaked at over 21°C, this Logger was inadvertently placed too close to a radiator so, although it showed a similar pattern to the other loggers, the overall T readings were 4 or 5°C higher, on average. However, it did show clearly when the heating was on and off. A detailed plot of this logger is shown in Figure 5.33 , which shows the heat coming on at 7:00 each morning and going off in the afternoon. The nocturnal lowest T is 15°C during this period (in November) with a diurnal high of 21.5°C. The rise in T is noticeable faster than the fall. For instance, on 13 November at 7:00 when the heat came on the T was 15.5°C and at 11.00 the T was 19.5°C, a period of four hours. T stayed at 19.5°C until 19:00 and then fell to 15.0°C at 7:00

on 14 November, over a period of 12 hours. This is a result of the thermal mass of the building where the fabric of the cathedral is being heated over the 5 hours or more of heating and the fact that it is bounded on two sides by other buildings which will provide thermal support. Figure 5.33 shows clearly the heating coming on, reaching a plateau for a period and then switching off.

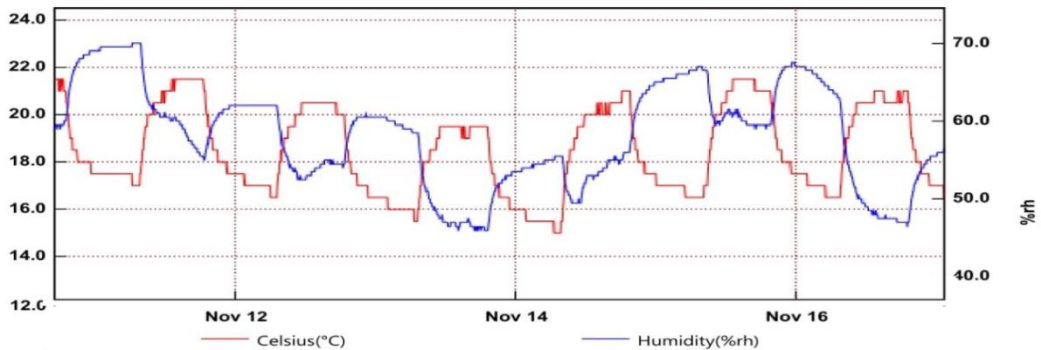

Figure 5.33 - Logger 3 in Pro cathedral Dublin showing the readings from 10th to 17th November 2015

Despite being placed widely apart in a large building the other loggers followed each other closely and in spite of the fact that the TinyTag was not in an ideal position, the loggers followed the approximate outside T fairly closely as well.

What is distinctive about this graph is the way the outside T goes up as it tends to each day, but the inside T rises because of the effect of the heating. Also, the heating is on for a given period rather than being set to achieve a particular temperature. This would imply that, as with St. Patrick's cathedral in Armagh, the heating system is set for a time-period and not set to maintain a particular T. The consequence of this can be seen in the period from 21 to 23 November 2015 when the outside T dropped to less than 12°C and the inside T almost matched it with some of the loggers showing 13°C. Any long period of cold weather would result in a more uncomfortable inside T and similarly any prolonged period of warm weather would result in uncomfortably high internal T readings. The average ambient T in this building is quite high at around 16°C which suggests that the boiler, the details of which are not known, could comfortably raise the T by a few degrees relatively quickly as is evidenced by the readings. Figure 5.34 shows logger 3 for one day which shows that the rate of increase is slightly greater than the rate of decrease as a result of thermal mass.

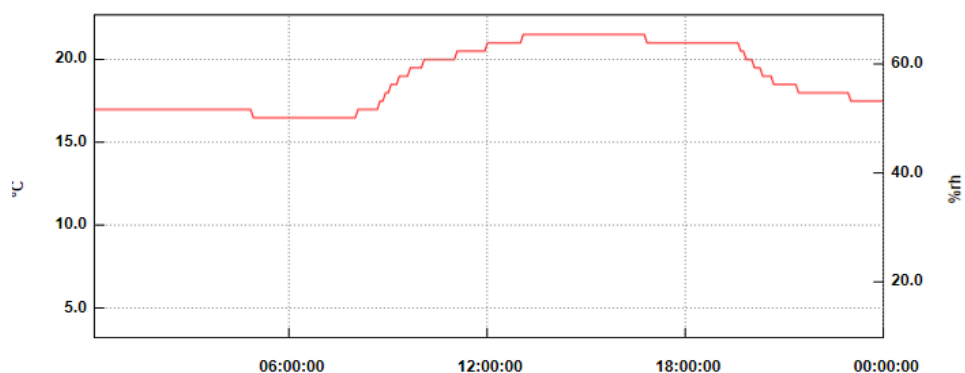

Figure 5.34 - Logger 3 in Pro cathedral for one day from 15th to 16th November 2015

The heat was on for most of the day and raised the T from 16°C to 21°C or by 5°C. It then took circa 8 hours for the heat to reduce from 21°C down to 16°C again. This was because the whole building was being heated and thermal mass was evening out the gradients in T.

This slow reduction in T means that heat is being wasted when the building is not occupied. However, RC cathedrals are open every day and particular in city centres, people regularly come in and out for short periods during the day for private devotions. The cathedral is surrounded by other buildings on two sides and this may have an effect in reducing the rate of cooling.

Logger 5 was situated in the organ loft at a height of circa 6 meters which explains its slightly higher T readings which are caused by slight stratification. The readings are still well within the accepted norms of 10 to 20°C for the safe keeping of the pipe organ. (IBO, 2003).

The rates per hour increases in T are shown in Figure 5.35 and, with the exception of Logger 3 which was placed too close to a radiator, the loggers show reasonable consistency in the rate per hour increase (about 0.5°C/hr) which denotes an even spread of heat throughout the building. This cathedral is unique in that it is very widely used, intermittently, all day with two main entrances to the cathedral. There is a constant stream of visitors coming to the cathedral for relatively short periods and so the two access points to the cathedral from the outside, are in frequent use. This will inevitably cause substantial air movements within the building which may result in different rates of heat loss or gain from the building. The shape of this building is also different in that it is almost as wide (circa 37 metres) as it is long (circa 43 metres) which may help to account for the even spread of heat throughout the building. It was stated at a meeting in the cathedral that part of the heating system was not functioning due to leaks. The average rate of increase per hour for the Pro cathedral is 0.56°C/h which compares with 0.32°/h for St. Mary's in Limerick. The differences are accounted for by the fact that St. Mary's in Limerick has an underfloor heating system and, as can be seen from Figure 5.40, the overall rate per hour increase is very low.

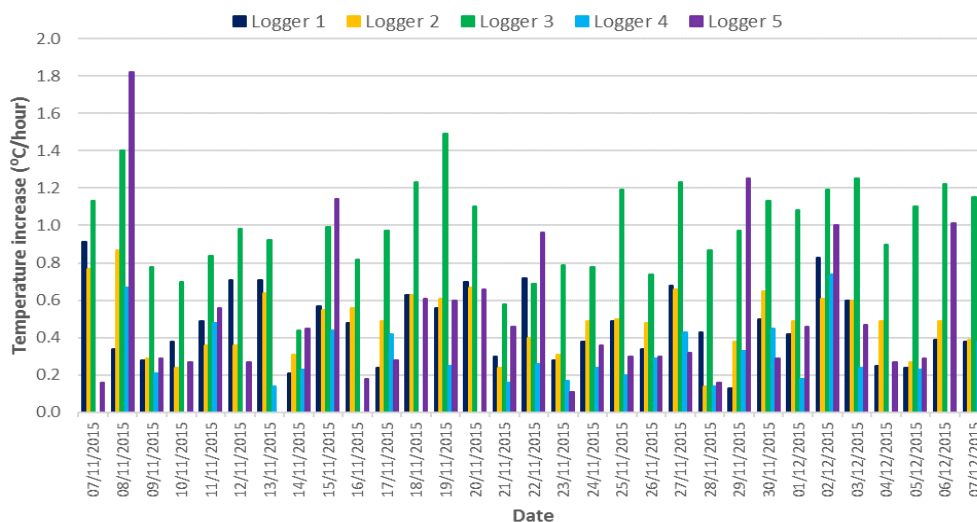

Figure 5.35 - Rate of temperature increase per hour in St. Mary's Pro Cathedral, Dublin

Relative Humidity

The Pro cathedral has many unique features such as its location, its usage pattern, its age and its dimensions. It has a world-famous choir and organ and the building is in constant use not just for regular services but also for important religious events as this is the pre-eminent Roman Catholic cathedral in the country's capital. These factors and others are likely to lead to unusual internal T and RH readings. The aspect which is most likely to affect these is the fact that the building is in constant use and with two doors to the outside which allow for easy ingress and egress of air.

The RH readings for the Pro cathedral are shown Figure 5.36. They mirror the outside RH readings, except on two occasions when there were large services and this implies a building which is porous and has a large egress of air which means that the internal and external RH readings are similar. Again, there is an obvious anomaly in Logger 3 which was, as previously explained, placed too close to a radiator. The higher readings for Logger 4 may be explained by the fact that it was near to a constantly used door, but does not explain why it was higher than the TinyTag. The obvious divergence of the readings from this logger around the 21 to 23 November 2015 and 28 to 29 November 2015 are not easily explained and the actual difference is around 15% which is quite high.

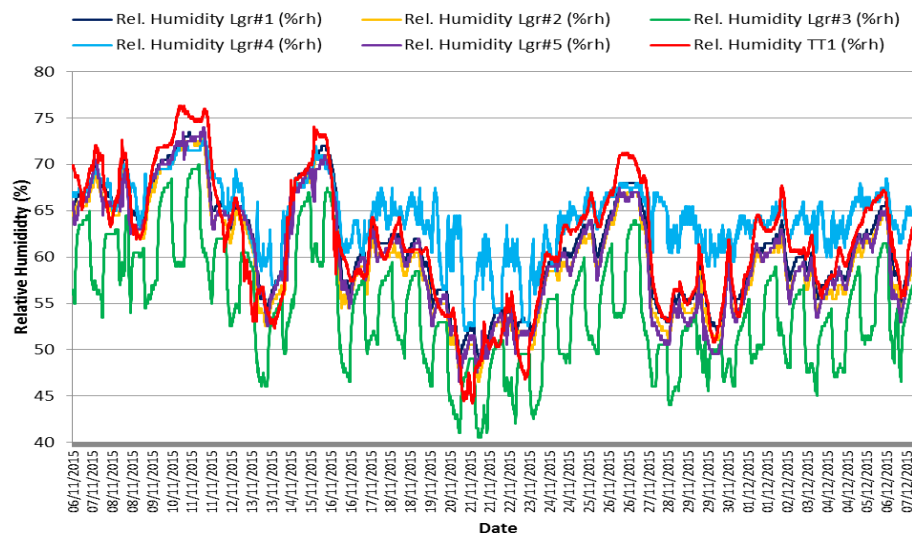

Figure 5.36 - Loggers in St. Mary's Pro Cathedral, Dublin showing RH inside the building

A search on the cathedral web site does show a large service on 22th November 2015 (Feast of Christ the King Mass) and 28th November (First Sunday of Advent Mass) where the Archbishop of Dublin was the celebrant which would indicate large numbers of people would be in the cathedral and this may have been a contributing factor in the larger RH values. The figures stayed high for two days which cannot be explained by one service, but it does appear that the higher RH readings around 22 November were the result of large numbers of people being inside the cathedral.

The cathedral can seat 1,100 people and Met Éireann, the national weather forecast service, reported that Sunday 22 November 2015 was relatively dry but with a sharp frost at night and the

weather on Saturday 28th November was very wet which may explain the high RH readings for Logger 4 but not the divergence. The TinyTag was not in an ideal position being inside an unheated area of the cathedral and this must be having a bearing on some of the readings for this instrument.

The RH readings show a mean range of around 55% which would not be detrimental to either the building or its contents. The internal RH readings closely reflect the outside RH readings as illustrated in the figure.

Ideally more loggers would have been available to monitor this large cathedral. Also, the loggers would ideally have been placed nearer to the center of the cathedral where most people sit, but this proved impossible for practical reasons. This cathedral managers, in spite of its unusual usage pattern to maintain an almost acceptable level of thermal comfort and the RH readings suggest that they are within acceptable ranges for conservation and preservation.

St. Mary's Cathedral, Limerick

This CI cathedral is one of the oldest in Ireland and hence it has been substantially changed and renovated over the centuries. Various internal chapels and walls have been added and removed which gives the cathedral, from the outside, the appearance of a collection of buildings rather than one building. It is situated in the fourth largest city in Ireland, namely Limerick, on the banks of the River Shannon, Ireland's largest river. It was originally built between 1168 and 1207 by the King of Thomond (Galloway, 1992). Due to its age it is difficult, without an architectural survey, to determine its various methods of construction but it has stone walls, some of which are almost certainly rubble filled and single glazed windows, many of which are stained glass. A flagged stone floor houses an underfloor heating system which was installed in a major renovation in the early 1990s. It is very unusual for such an old building to have an underfloor heating system because it is usually not possible to disturb the floors in such buildings as a result of the many burials which would have taken place inside the buildings.

Two new gas boilers were installed approximately five years ago. The cathedral has a wooden ceiling and a traditional tiled roof. Whilst not known, it is almost certain the building has no insulation of any type. Similar to many cathedrals, this one has a pipe organ which is in regular use and so the internal environment is important for the proper functioning of this instrument.

The locations for the various loggers installed in St. Mary's Cathedral can be seen in Figure 5.37 and Appendix 7. All the loggers were at a height of approximately 2.5 meters and the TinyTag was situated outside the belfry at a height of some 15 meters.

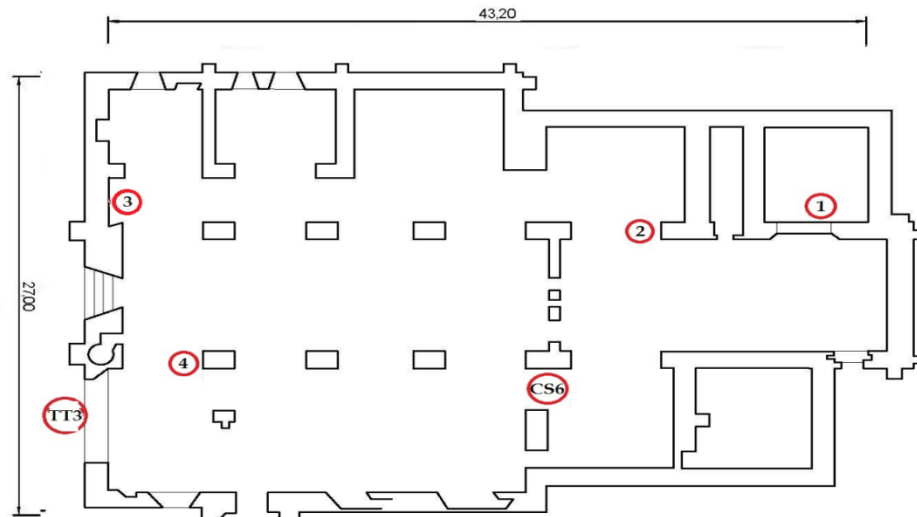

Figure 5.37 - Floor plan with loggers location St. Mary's Cathedral, Limerick

Temperature

There is good uniformity when the T readings from the loggers are compared (Figure 5.38) which is to be expected with an underfloor heating system which is constantly on.

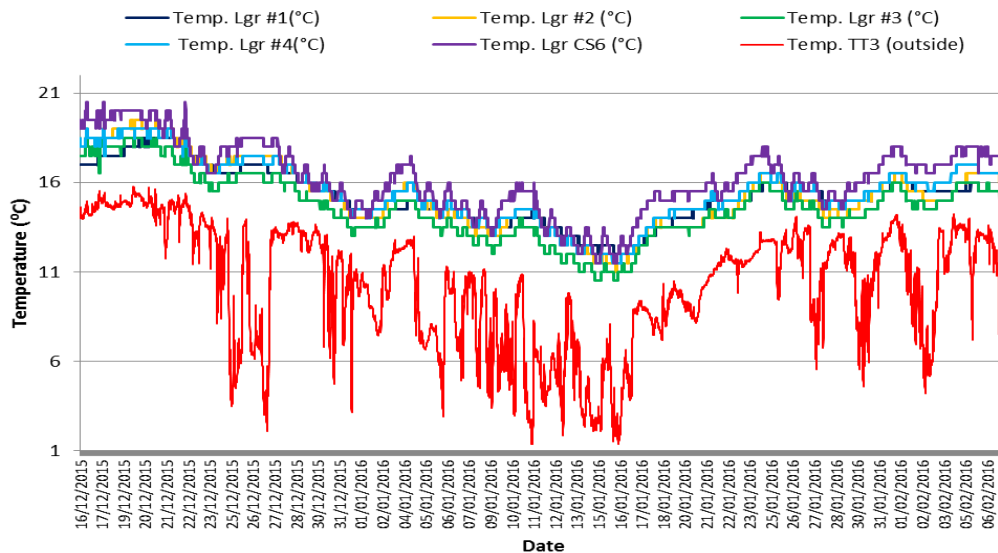

Figure 5.38 - Temperature readings for St. Mary's Cathedral, Limerick

What is noticeable is the way in which the internal T readings gradually follow the outside T readings which occurs because the boilers are set to come on and off for a set period of time rather than to maintain a particular T. So, when the outside T starts to reduce, for instance around 4 January 2016, so does the inside T, resulting in an uncomfortably low internal ambient T reading of just over 11°C on 15/16 January. Figure 5.39 illustrates the readings for logger 4 over a one week period from 12 to 19 January 2016. It shows initially a small but gradual decline as the outside T reduces, and then a small but noticeable increase as the outside T increases.



Figure 5.39 - Logger 4 for St. Mary's CI cathedral, Limerick from 13 to 19 January 2017

The rate of increase per hour is shown in Figure 5.40 and is around 0.25°C/hr. They show a very even spread throughout the building which again is what would be expected with underfloor heating which is constantly on during the day. This cathedral has a floor made up of large flag stones and these may also have had an effect in reducing and evening out the rate/h increase although stone flags do not have a lot of thermal mass when compared with, say, solid stone walls. Some cathedrals with underfloor heating have tiled floors and further research could be undertaken to establish what bearing the size of the components of the floor has on the readings. There are a few high isolated readings which can be ignored as they are anomalous for no discernible reason.

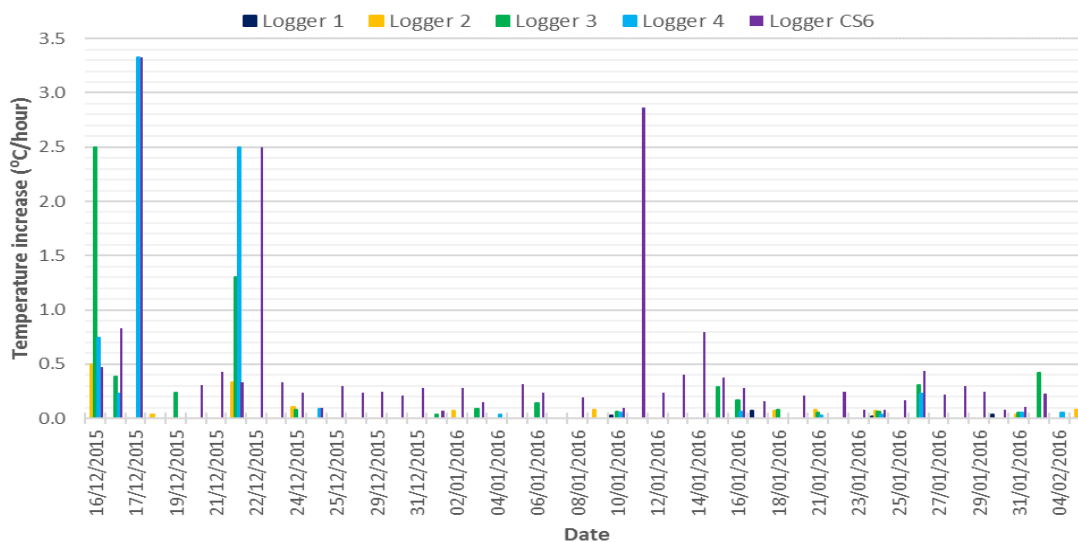

Figure 5.40 - Rate of temperature increase per hour in St. Mary's Cathedral, Limerick

Moisture

The RH readings (Figure 5.41) are not as clear in terms of patterns as the T readings though they are largely between 50 and 70%RH, due principally to stable T values induced by the underfloor heating system. The outside RH readings show a period of high RH during periods of rain and high moisture content in the air. The internal RH readings tend to follow each other with slightly higher readings for

logger 3 in the middle of the recording period. The average ambient RH readings are circa 65% which is a safe level in terms of the building and its contents, in particular the organ

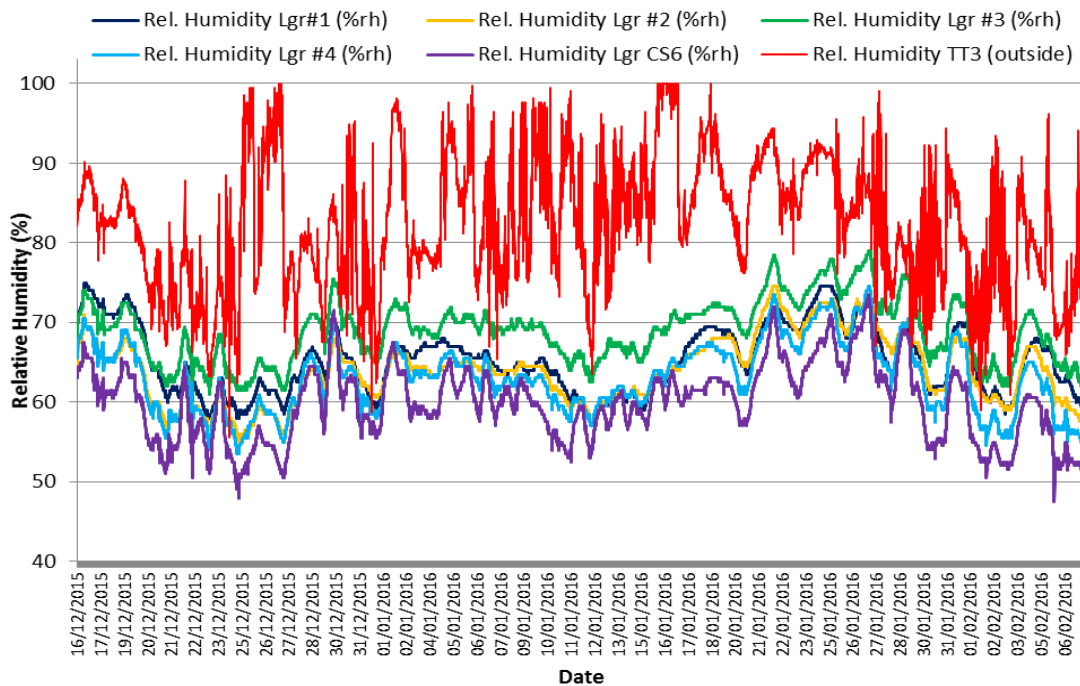

Figure 5.41 - Relative Humidity readings in St. Mary's Cathedral, Limerick

Assumption of the Blessed Virgin Mary Cathedral (RC), Killarney

The reasons for highlighting this cathedral are because it uses an underfloor and LPHW system which is used in other cathedrals but the researcher noticed that the floor temperature above the underfloor heating seemed very high at 39.5°. On two separate occasions the floor T readings were 39.5°C on the underfloor heating while 20m away, where there was no underfloor heating, the T was 20 °C. The researcher wanted to investigate if this cathedral displayed the traditional characteristics of such heating systems, and to observe if these exceptionally high T readings had distorted them in any way. The logger readings suggest that they did not, but further research could be carried out to establish firstly if the floor readings were frequently attained and furthermore if they were, what other effects such high readings might have on the building and its contents.

The monitoring of the T and RH figures was executed by installing 5 loggers inside the cathedral and one in the tower at a height around 30 meters. A more detailed position of the loggers and TinyTag is shown in the floor plan for St. Mary's Cathedral in Figure 5.42 and in Appendix 8.

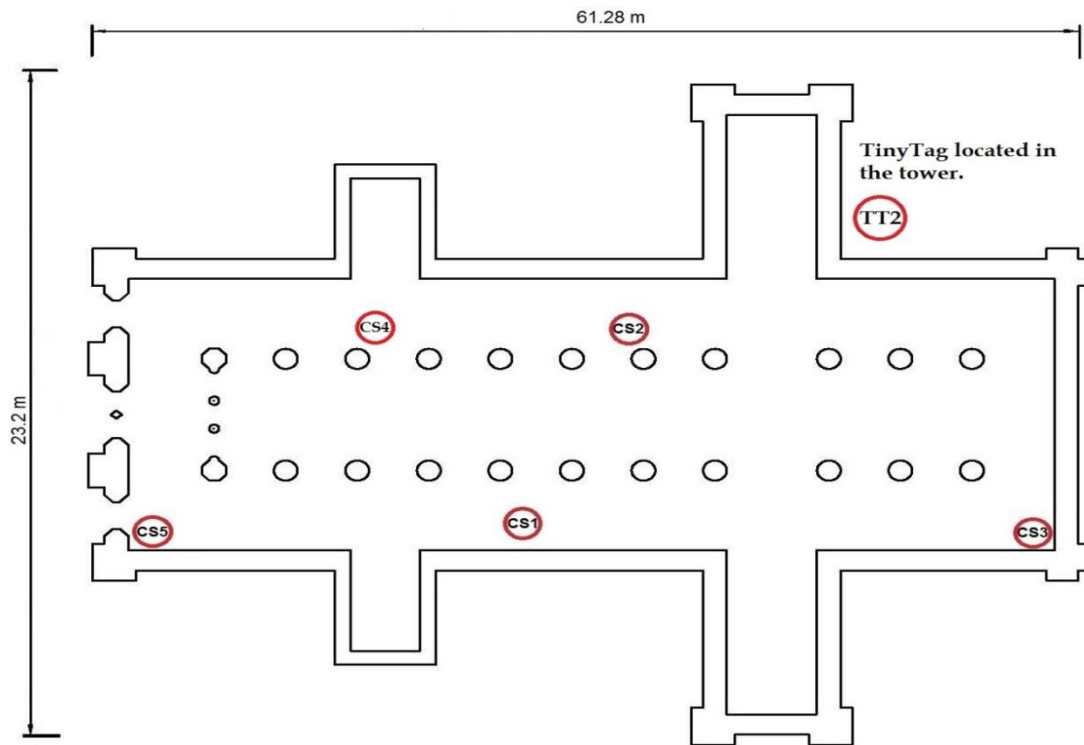

Figure 5.42 - Floor plan St. Mary's Cathedral, Killarney

Temperature

The T readings, including the external TinyTag readings, are shown in Figure 5.43.

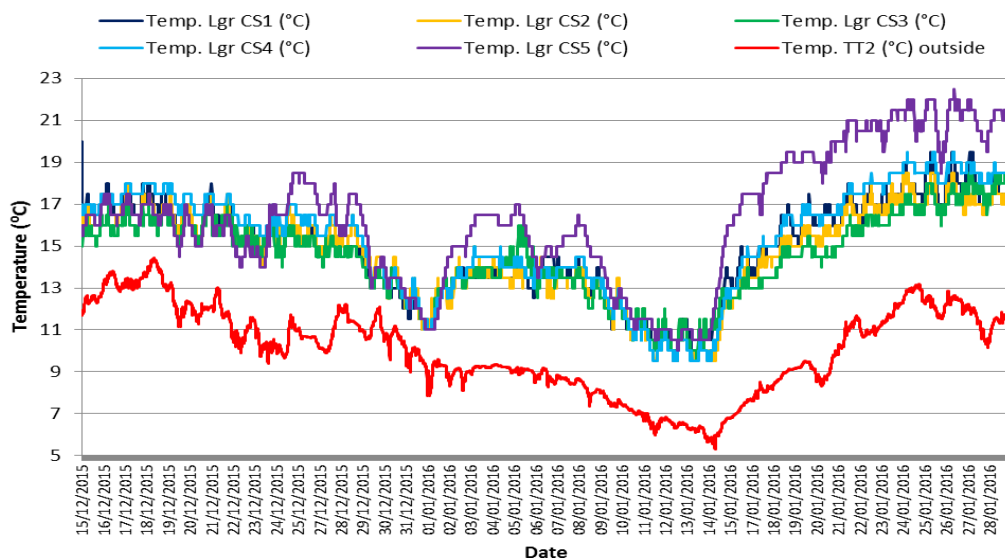

Figure 5.43 - Temperature readings (indoors and outdoors) in Assumption of the Blessed Virgin Mary cathedral, Killarney

Apart from logger CS5, the loggers follow each other closely with only a small variation and the general movement is quite similar to that in Figure 5.41 which is not unsurprising since the readings were for cathedrals with active underfloor heating systems. Logger CS5 was situated near to the door and it would be expected that this would reduce the readings from that logger instead of which the readings are slightly higher. Further research is needed to discover why this particular logger has the

profile which it does. What is clear is that the inside T readings have low daily ranges and follow the outside T readings which is, again, because the heating is on for a given period each day rather than being set to reach and maintain a particular T setting. The average ambient T is around 16 to 17°C which is relatively high for an Irish cathedral (c.f. 11°C to 18° in Figure 5.41) and especially for one which does not charge for entry. Comparing the amalgamated T readings from St. Mary’s in Limerick (Figure 5.38), and there are obvious similarities because both involve underfloor heating. Moreover, if they are compared with the Pro cathedral in Dublin (Figure 5.32), which has a LPHW system, the T profile is quite different with much sharper and greater T rises and falls.

In Figure 5.43 a sharp increase in T can be observed on 15th January 2016. Figure 5.44 shows this particular week in detail for logger CS2, as being representative of the other loggers. It is noted that there is quite a sharp increase in outside T and that, combined with the fact that the cathedral would not have been used as much in the New Year period and hence the heating may have been turned off, as it had been at Christmas and this may have resulted in this sharp increase. The managers may have noticed that the ambient T had fallen to 9.5°C and may have altered the heating regime to account for this. The sharp increase in T on 1 January and 14th January must be because the manager of the cathedral realized that the T had dropped to an unacceptable level and switched on the LPHW system which also exists in this cathedral. Ideally an underfloor system keeps a low but stable ambient T and the LPHW system can then raise T for a short period for a service for instance.

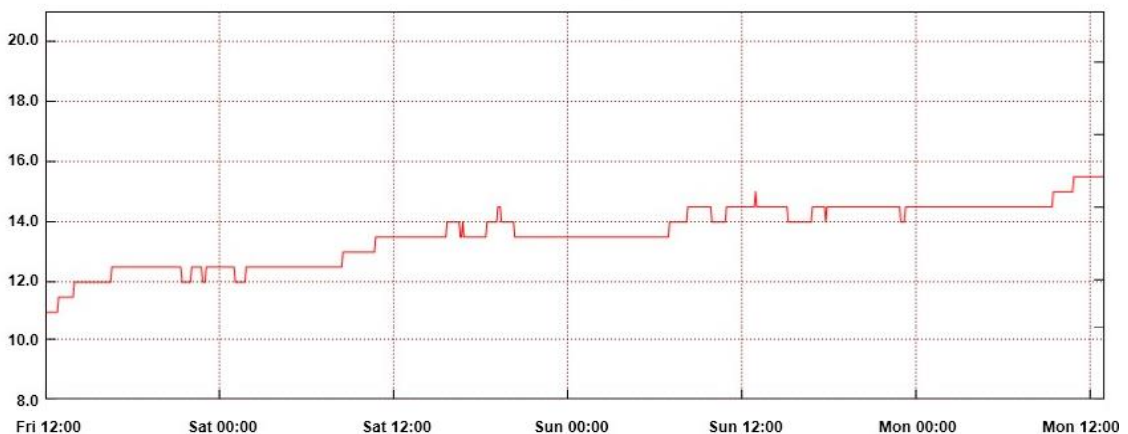

Figure 5.44 - Killarney cathedral logger CS2 from January Friday 15th to Monday the 18th

It is possible to observe from these readings that the external environment is having greater influence on the internal environment than the heating system, probably because the underfloor heating is not on for long enough to be effective.

The rates of increase per hour are shown in Figure 5.45 and whilst there are some anomalies in the readings from Loggers CS3 and CS2, the average increase is less than 0.5°C per hour, which is slow but faster than St. Mary’s in Limerick. The graph is overlaid with the outside Tinytag readings to identify if any correlation exists between the two sets of readings and there does not appear to be

any such connection. Logger CS3 which produced some very high rates must have been affected by an external heat source, such as sunlight coming through the windows from the opposite side of the church, to produce such large and unusual fluctuations.

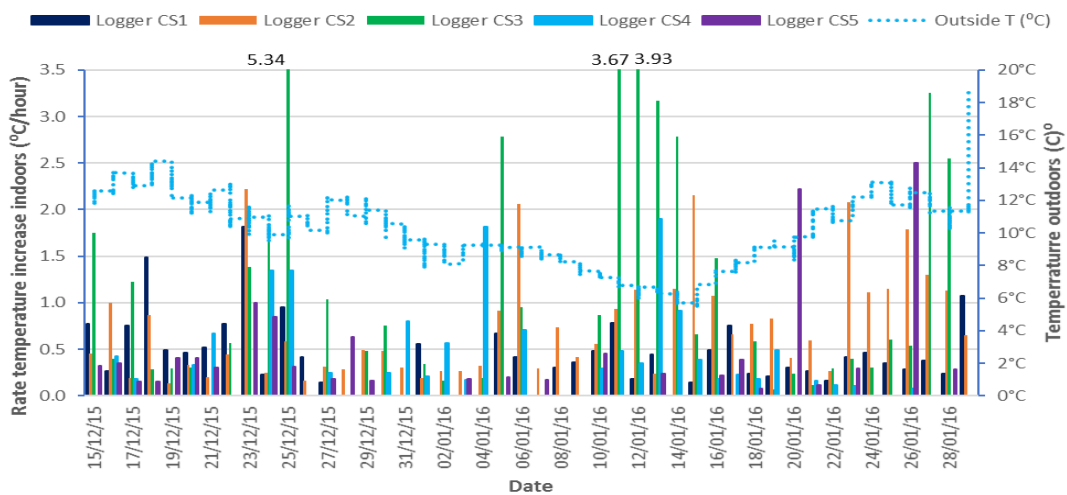

Figure 5.45 - Rate of temperature increase per hour in Killarney Cathedral

Moisture

This cathedral is situated on a river flood plain in a very prominent position on the outskirts of Killarney, which is a major tourist town in South West Ireland. The RH figures are shown in Figure 5.46 and once again, except for Logger CS5, they are uniform and tend to follow the outside TinyTag readings implying that due to slow changes in T, RH changes are more influenced by external RH than T which in turn implies a high rate of infiltration.

This uniformity would be expected from an underfloor heating system, even one which is supplemented with an LPHW system as is the case here. Whilst there is a maximum figure of over 80% and a minimum of less than 40%, the ambient of circa 60% is acceptable from the point of view of the conservation and preservation of the building and its contents, in particular the pipe organ though a range of 40% may not be desirable.

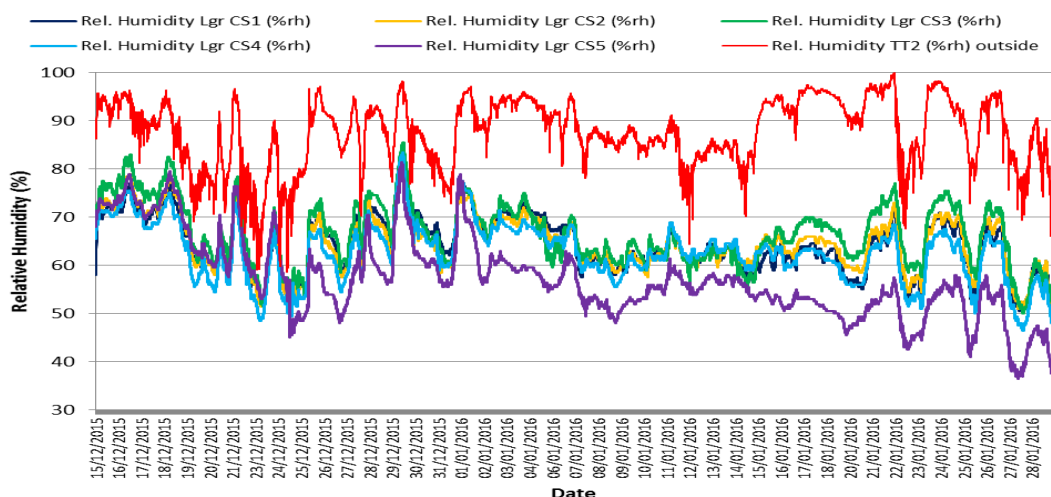

Figure 5.46 - Relative Humidity readings in Killarney Cathedral

What can be deduced for underfloor heating systems is the following:

- They produce stable internal T and RH readings.
- They generally produce low rate per hour increases in T and RH if left on during the day.
- They generally produce an even spread of heat throughout the building.
- They are less efficient when used intermittently.
- A high rate of infiltration means that internal T and RH will follow external T and RH due to slow changes in T internally.

This type of system is not suitable for intermittent use since it takes a long time to heat up and cool down and with most cathedrals only used intermittently it may not be a suitable system unless the cathedral can afford to leave it on all the time at a low level and then bring the heat up for events.

The intermittent use of the underfloor heating system in this cathedral means that the internal environment tends to follow that of the outside with the result that, at times the internal T readings fall below what would be acceptable for thermal comfort. The RH readings are reasonable and within the recommended levels for conservation and preservation.

St. Mel's Cathedral (RC), Longford

The reason for highlighting this RC cathedral was because it is the newest cathedral in Ireland with the most up-to-date heating system and, although an underfloor system supplemented with trench heating, is installed in other cathedrals, it was believed to be important to examine how well an entirely new, properly designed, heating system performed inside what is, a typical large cathedral in terms of size, location and usage.

St. Mel's cathedral in the town of Longford in the centre of Ireland is unique in that it was burnt down on Christmas Eve 2009 and rebuilt and reopened for Christmas services in 2014 at a total cost of some €30M. The fire was caused by soot in the boiler chimney catching fire after the boiler was switched off, having been running for a considerable length of time. An open vent allowed oxygen to enter the chimney and ignite the cinders and ash which had built up there. The weather was so cold that night that the water in the local pipes froze and the fire brigade was unable to put out the fire. The only parts of the cathedral left standing after the fire were the walls and belfry, as shown in Figure 5.47. St. Mel's cannot, strictly, be considered as a new or indeed modern cathedral since the walls were left standing and hence have no insulation in them, as a modern built cathedral would have.

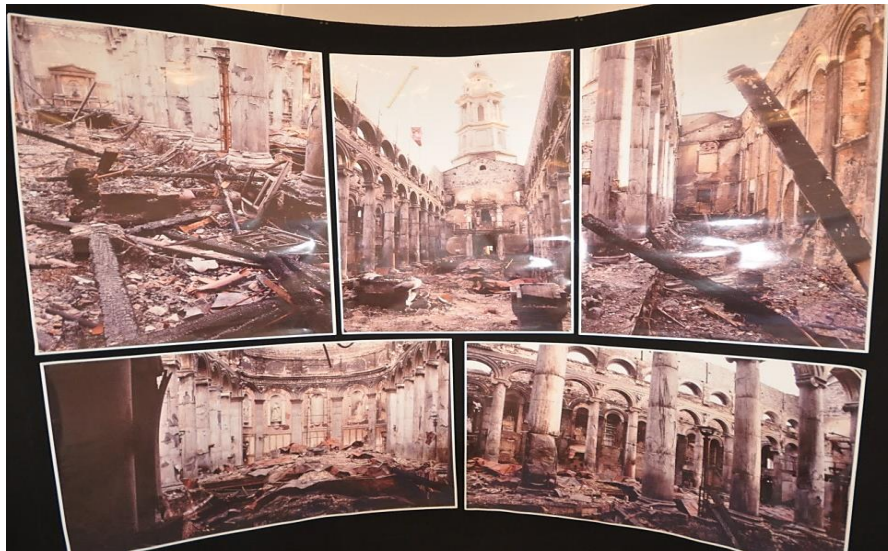

Figure 5.47 - St. Mel's cathedral after the fire in 2009

Figure 5.48 shows the cathedral when it reopened in 2014. An interview was held with an engineer from ARUP consulting engineers, who were the main designers of the mechanical and electrical installation, who stated that after a full consultation about the use to which the cathedral would be put, and taking into account all of the other parameters (such as construction, size, location and cost), it was decided to install underfloor heating backed up with an LPHW system powered by two condensing gas boilers. It was also decided to install large amounts of insulation in the floor and ceiling, but not the walls. The insulation comprises 135mm insulation under the floor together with 65mm of self-levelling screed. There was a maximum of 200 mm available for the screed and insulation above the naturally ventilated crypt which limited the depth of insulation which could be used. St. Mel's, being a protected structure, is exempt from Part L of the building regulations (DOEHLG, 2011) but the owners decided that where possible they would comply voluntarily with the regulations. Part L specifies an elemental U-value for floors of $0.15 \text{ W/m}^2\text{K}$ and the described insulation will achieve this. In the roof of the cathedral there is 200mm of insulation. The regulations specify 145mm to achieve a U-value of $0.16 \text{ W/m}^2\text{K}$ for pitched roofs insulated at ceiling level. Calculations were carried out by the consulting engineers, to ensure that condensation would not occur in the roof void and these included variances from -5°C to $+25^\circ\text{C}$ and RH up to 75%. This over-specification of insulation in the ceiling was to compensate for the lack of insulation in the walls. The new heating system combined with the insulation accounts for the higher rate of temperature increase per hour achieved.



Figure 5.48 - St. Mel's cathedral, Longford after being rebuilt in December 2014

Provision was made in the installation for future connection to a district heating system and for solar collectors.

The T and RH measurements were carried out in March and April 2015 shortly after the building was reopened and tests on various parts of the building were still being carried out by the contractors. The building had almost certainly not completely dried out at the time of the measuring and this may have affected some of the RH readings.

Temperature

The floor plan with the position of the loggers in the cathedral is shown in Appendix 9. The outside monitor (TinyTag) was placed in position on a building just beside the cathedral.

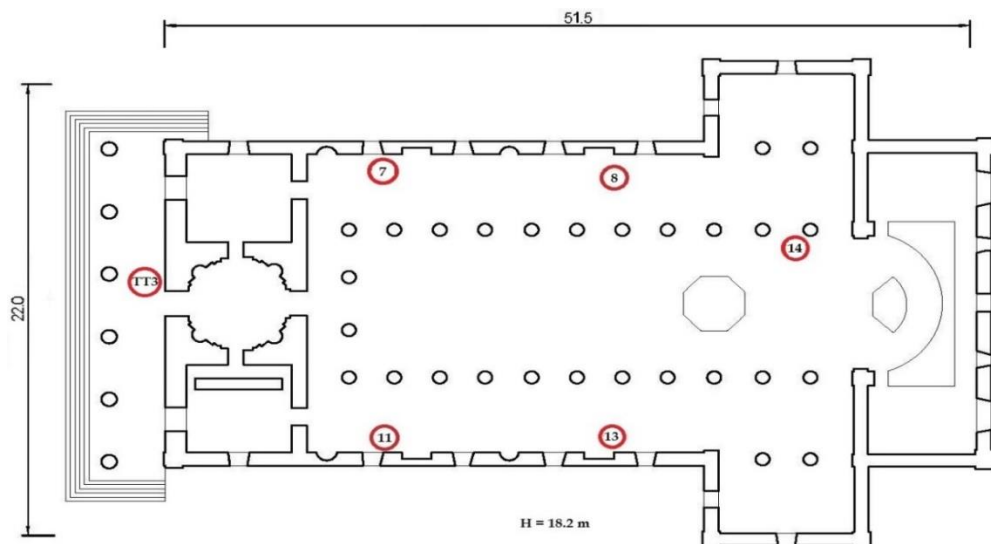

Figure 5.49 - Floor plan St. Mel's Cathedral, Longford

All the loggers and the TinyTag were placed at a height of circa 2 meters. The cathedral has solid stone walls, a tiled and wooden floor, single glazed (but with storm glazing) windows, a plaster ceiling and a traditional tiled roof. These materials are new as are the timber pews and wooden internal fittings. The cathedral had a new and very large pipe organ installed as part of the rebuild.

The loggers readings for T are shown in Figure 5.50 but the Tiny tag readings are shown separately in Figure 5.51 because the TinyTag was inadvertently set to take readings every 15 minutes rather than 5 minutes. This does not invalidate the TinyTag readings.

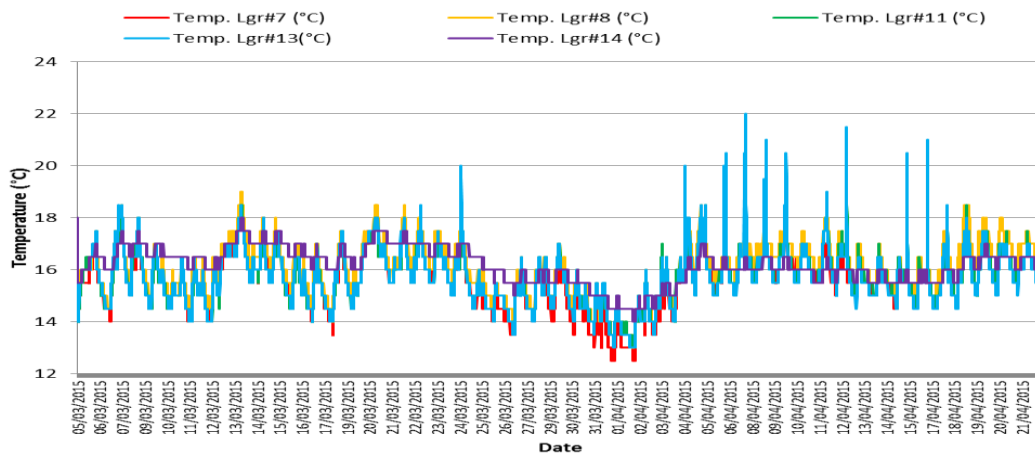

Figure 5.50 - Temperature readings indoors of St. Mel's Cathedral, Longford

Except for logger 13, the readings are very stable with an average ambient T of circa 16°C. This graph is not dissimilar to Figure 5.38 - Temperature readings for St. Mary's Cathedral, Limerick) and Figure 5.43 - Temperature readings (indoors and outdoors) in Assumption of the Blessed Virgin Mary cathedral, Killarney which are for the other two cathedrals in this group with underfloor heating. The ambient T in St. Mel's is comparatively low but comfortable and no doubt the system was still under test and can be adjusted later. The cathedral was also monitored slightly later in the year namely around April whilst the other two were measured in January and the heating in St. Mel's may have been turned down because of this, despite the low external temperatures (as low as 4°C in Figure 5.51).

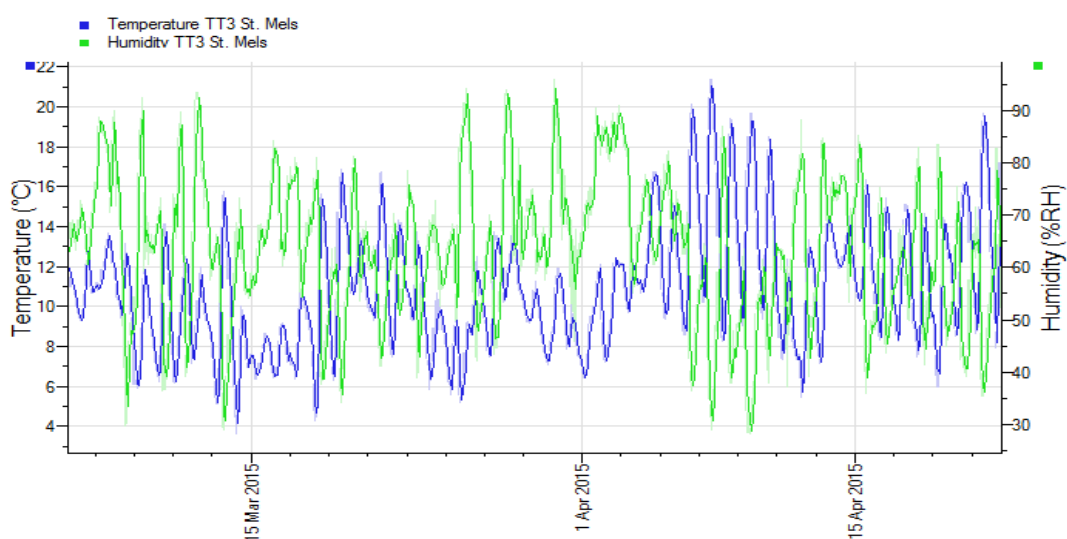

Figure 5.51 - TinyTag readings for temperature and relative humidity outside St. Mel's Cathedral, Longford

The rate of increase per hour is shown in Figure 5.52 and it is possible to discern a pattern from the readings. Unusually there are periodic fluctuations where it appears that low outside T readings are

reflected by higher internal T readings which suggests that the boilers are working harder when the outside T is lower. The inverse is also true in that high outside T readings seems to be reflected by lower internal T readings as seen towards the latter end of the monitoring period in the figure below. This would suggest reactive BMS is at play in controlling the heating system. Unfortunately, the cost of running this system was not available.

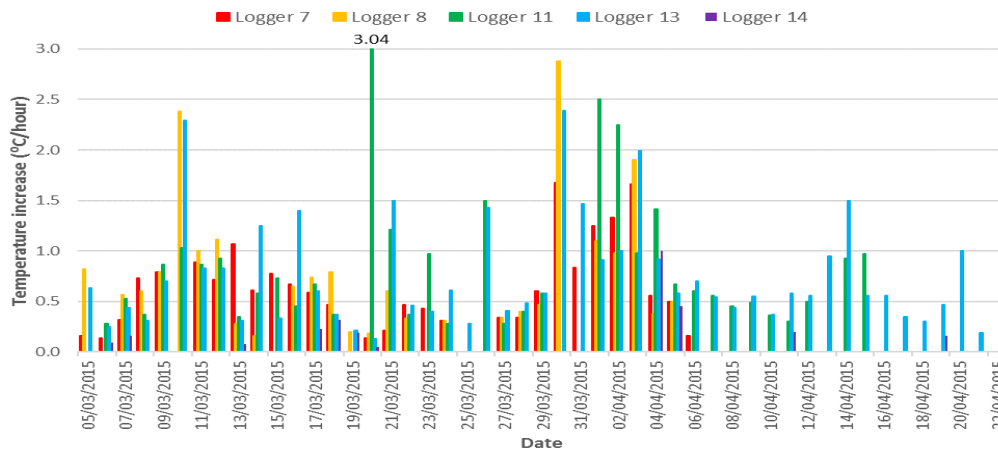

Figure 5.52 - Rate of temperature increase per hour in St. Mel's Cathedral, Longford

Moisture

The composite graphs for the internal RH readings are shown in Figure 5.53 and the range is between 50% and 70% with an average of circa 60%. There is good uniformity between the loggers except for the troughs for logger 13 which match the peaks for T for the same logger. The outside RH fluctuates between 30% and 95% so once again it is noted that the internal environment is not being unduly influenced by the outside environment. The fact that the loggers follow each other so closely is not surprising with an underfloor heating system delivering uniform T but it is perhaps not surprising that they should do so in such a new building. This is also perhaps indicative of low rates of infiltration due to good sealing of this new building which is also well insulated which will assist with stabilising the internal environment.

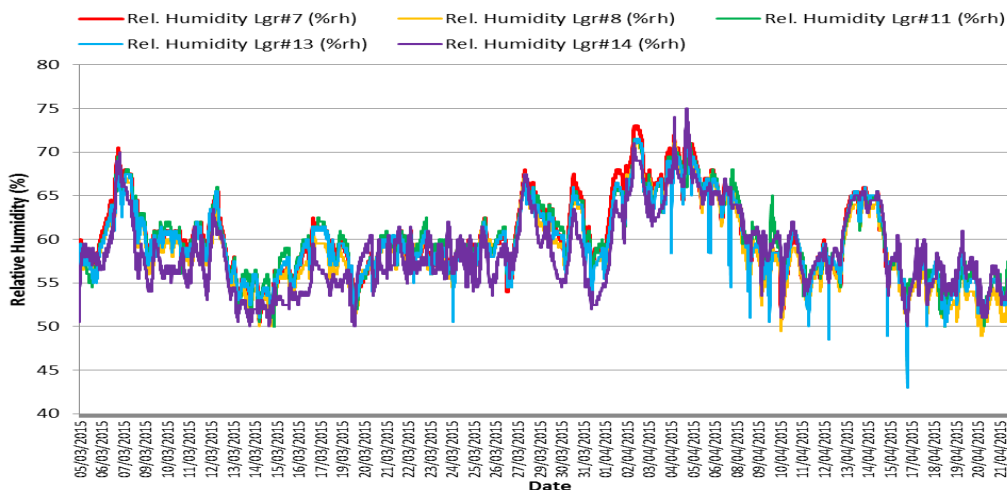

Figure 5.53 - Relative Humidity readings indoors of St. Mel's Cathedral, Longford

This cathedral would require more loggers to monitor it adequately and these loggers should be located, if possible in the nave rather than against the outside walls. However even with these limitations it is obvious that this well insulated building does provide adequate levels of thermal comfort and is within acceptable levels for conservation and preservation.

5.2.2 Large Cathedrals not monitored

The two cathedrals which were not monitored in this group, namely Mullingar and Derry RC, both have LPHW systems with Mullingar using oil, and Derry, gas. The two cathedrals are very similar in their usage as they are both city centre cathedrals owned by the Roman Catholic Church and so are open every day and are used extensively. Mullingar is the younger of the two cathedrals by some 70 years and the two cathedrals look very different from the outside, with Derry being Gothic in style and Mullingar being more like a Basilica with its two towers over the West end. Because of its exposed hill side location, Derry cathedral had to undergo extensive refurbishment in the 1980 and 1990s. Internally Mullingar had covered the radiators with marble which was pleasing aesthetically but further research could be carried out to see what effect this had on the reduced thermal performance of the radiators. It was noticed that the marble surrounding the radiators remained warm for some time after the heat was turned off.

5.2.3 Key findings for large cathedrals

A definite trend is discernible both with these cathedrals and the very large category whereby the many cathedrals who set their heating for a particular period of time (rather than setting a particular internal temperature) find that the internal environment is more influenced by the external environment. Extended periods of cold or warm weather during the heating season will result in uncomfortably cold or warm internal temperatures and with corresponding and inadvisably large variations in RH.

From the readings available, it appears that St. Mel's cathedral, with its new underfloor heating system and unusually good levels of insulation, has achieved a very stable internal environment, independent of the external one, but presumably at a cost. Even with its, what might be considered, traditional system of underfloor and LPHW heating systems, it seems to be operating within all the advisable T and RH parameters regarding providing reasonable levels of thermal comfort and adequate conservation and preservation levels. Permission should be sought to monitor this cathedral for a full year and the performance might then become the standard against which all other similar cathedrals could be measured.

Other observations are:

- Rates of infiltration and exfiltration are important in determining how closely internal and external T and RH follow each other.

- LPHW systems can lead to wasted heat if the heating is left on long enough to heat the fabric of the building.
- LPHW heating systems can lead to much greater variances in T and RH than underfloor systems.
- Underfloor heating systems, if not operated intermittently can lead to stable internal T and RH figures and low rates of increase per hour.
- Size is not the dominant factor in determining internal T and RH rates since large and very large cathedral within similar parameters perform similarly. Usage is one of the most important parameters in determining the internal environment.
- Insulation was confirmed as displaying a major role in stabilising the internal environment.
- Where underfloor systems are augmented with other types of heating such as trench/LPHW, further research is need to establish the contribution of each system to the overall internal environment.

5.3.1 Medium Cathedrals

Using the premise that a cathedral which is between 10,000m³ and 20,000m³ is considered a medium sized cathedral, it can be observed that 18 Irish cathedrals fall into this size category. Of these 18, which is 32% of the total of 57, 12 are owned by the Roman Catholic church and 6 by the Church of Ireland. Of these 6, 4 are the smallest in the group. Of the 18 cathedrals, 7 (or 39%) were monitored for at least a month. These medium sized cathedrals are spread throughout the island of Ireland and have a wide variety of heating systems and heating regimes employed. Table 5.3 shows the details of the cathedrals and the heating types employed within them. Due to the variety of the monitored cathedrals within this group it is difficult and often inappropriate to try to group them together. They also represent a wide spectrum of ages and include some of the oldest cathedrals in Ireland such as Christ Church cathedral in Dublin, St. Patrick's cathedral in Armagh and St. Columb's cathedral in Derry/Londonderry.

Table 5.3 - Medium cathedrals (between 10,000 m³ and 20,000 m³), with age, heating type and fuel used

City	Name	Size (m ³) approx.	Age	Heating type	Fuel
Cork*	St. Fin Barre's (CI)	19,400	1870	Trench & Underfloor	Gas
Waterford	Most Holy Trinity (RC)	17,700	1893	LPHW	Oil
Cavan	St. Patrick & St. Phelim (RC)	17,500	1942	LPHW	Oil
Dublin*	Christ Church Cathedral (CI)	17,000	1172	Trench & LPHW	Gas
Sligo	Immaculate Conception (RC)	17,000	1874	LPHW	Oil
Letterkenny	St. Eunan & St. Columba Cath.	16,000	1901	LPHW	Oil
Thurles	Cath. of The Assumption (RC)	15,500	1879	LPHW	Oil

City	Name	Size (m ³) approx.	Age	Heating type	Fuel
Belfast*	St. Peter's Cathedral (RC)	15,000	1866	Underfloor	Gas
Enniscorthy	St. Aidan's Cathedral (RC)	15,000	1945	LPHW	Oil
Tuam	Cath. of The Assumption (RC)	14,500	1837	LPHW	Oil
Kilkenny*	St. Mary's Cathedral(RC)	13,500	1857	Underfloor & LPHW	Oil
Ballina	St. Muredach's Cathedral (RC)	13,500	1892	LPHW	Gas
Cork*	St. Mary & St. Anne Cathedral (RC)	13,000	1808	Hot Air & Elect. Radiant	Gas
Ballaghadereen	Anunciation of Blessed Virgin Mary & St. Nathy	12,250	1860	LPHW	Oil
Armagh*	St. Patrick's (CI)	12,000	1837	LPHW	Oil
Cloyne	St. Coleman's (CI)	12,000	1172	Storage	Elec.
Waterford	Christ Church Cathedral (CI)	11,000	1792	Underfloor & LPHW	Gas
Derry*	St. Columb's Cathedral(CI)	10,000	1633	LPHW under pew blower	Gas

*Note: monitored

The monitored cathedrals have a number of unique features, which is one of the reasons why they were chosen to be monitored, as follows:

Cork (CI)	Heating system organ, usage.
Dublin (CI) (Christ Church)	Age, heating system, usage.
Belfast (RC)	Heating system, location, usage.
Kilkenny (RC)	Location, usage, heating system.
Cork (RC)	Heating system.
Armagh (CI)	Importance, heating system, usage.
Derry (CI)	Location, heating system.

Rather than comparing these monitored cathedrals, as they are all quite different, they will be looked at individually.

St. Mary and St. Anne's cathedral, Cork.

This Roman Catholic cathedral is different in that it employs a gas fired hot air blower system of heating backed up with small electric radiant heaters, sited in the nave. It is not known if there was any insulation in the building. What is unusual about this cathedral is the fact that the hot air is delivered from one source, which is a grill on the North wall of the sanctuary, as is shown in Figure 5.54, supplemented by the electric radiant heaters also located in the nave.



Figure 5.54 - Hot air blower outlet (left) and Electric radiant heaters (right) in St. Mary's Cathedral, Cork

Temperature

This cathedral differs from other cathedrals in Ireland because its rate of T increase is consistently greater than 5°C/hr with an average of 9.6°C/hour, reaching peaks of around 20°C/hour, which can be observed from Figure 5.55. St. Mary's Cork was the only monitored cathedral to achieve such fast warm up times which is why it has been chosen for particular examination.

It has not been possible, with the methods adopted, to discover if this very high rate of warming up of the interior of the building is a result of the hot air blower system, the radiant heaters or a combination of the two. It is not likely that the positioning of the loggers has anything to do with the high rates because care was taken to ensure that they were not in line with the radiant heaters and empirical evidence (namely interviews with the sacristan) indicates that the radiant heaters are not used every time that the hot air system is employed.

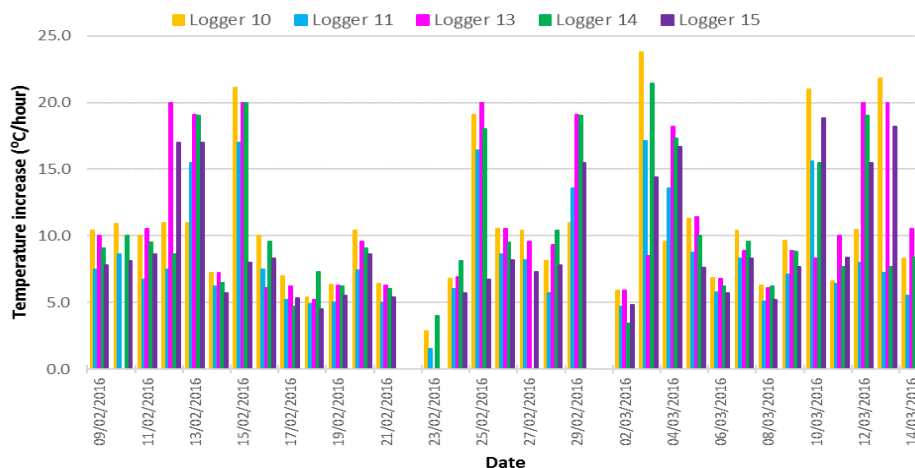

Figure 5.55 - Rate of temperature increase per hour in St. Mary's cathedral, Cork

The usage pattern for this cathedral is very similar to all other RC cathedrals in that it is in constant daily use. There are two doors which give access to the outside and a further door which leads onto internal offices.

The locations of the loggers in St. Mary's (Cork) Cathedral can be seen in the floor plan in Appendix 10 and they are reasonably evenly spread throughout the building, at a height of circa 2 meters. It

was not possible to find locations on the inside of the external walls to fix the loggers and so they were fixed to audio speakers which in turn were fixed to the pillars dividing the aisles from the nave.

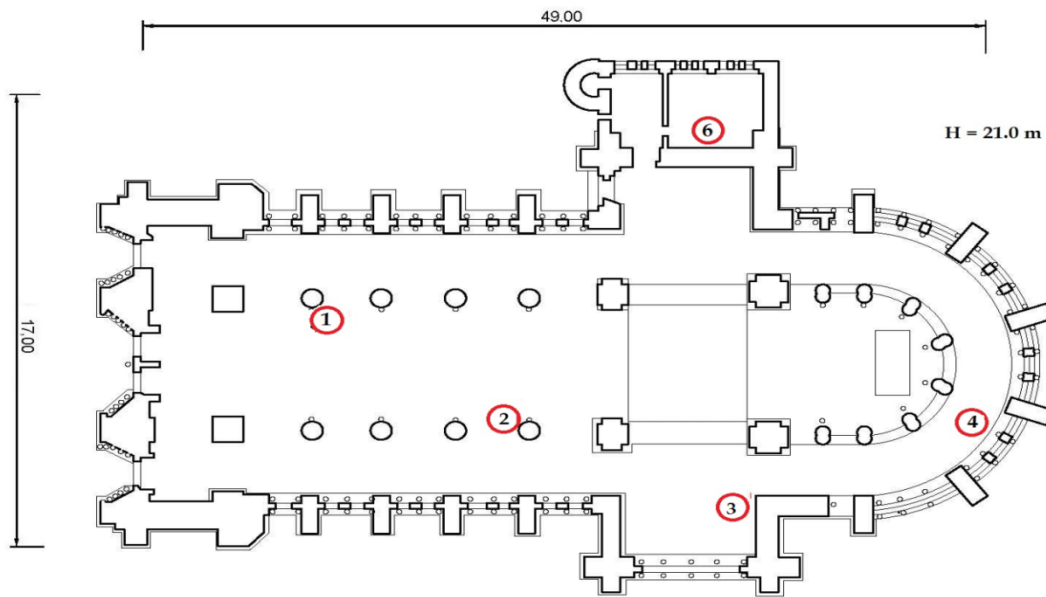

Figure 5.56 - Floor Plan St. mary's and St. Anne's Cathedral, Cork

The internal and external T readings for this cathedral are shown in Figure 5.57.

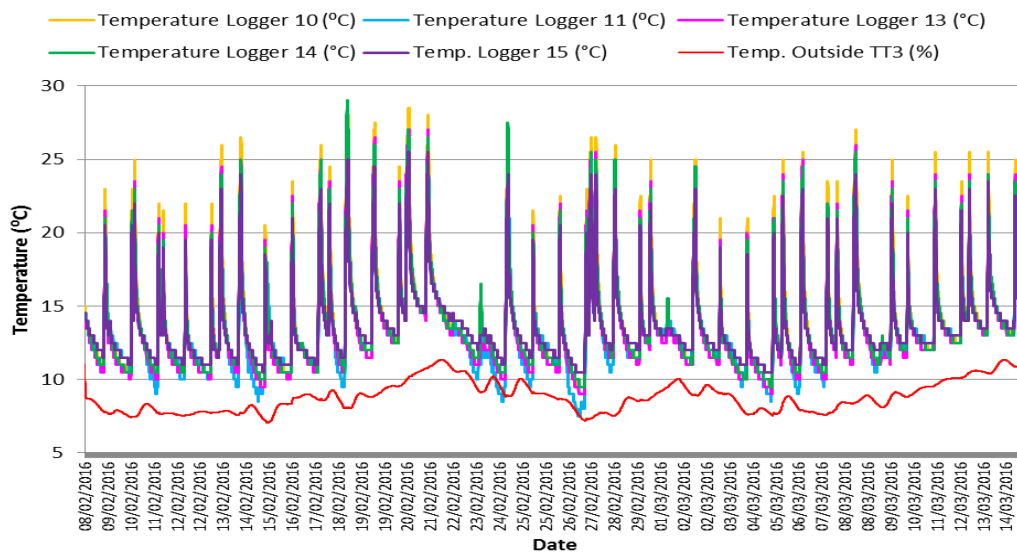

Figure 5.57 - Temperature readings (indoors and outdoors) in St. Mary's Cathedral, Cork

Unfortunately, access to the roof of the cathedral was not possible and the TinyTag was placed in the unheated stairwell going up the belfry which, being technically inside, was not an ideal location. The results from the TinyTag for T are reasonably representative of the outside values when checked with Met Éireann but they do not explain the very rapid rise achieved in the internal T values.

The generally rapid rise is also followed by a rapid fall, apart from the period between 20th to the 23rd February, which coincided with a period of rising outside T. The high peaks in the T readings are consistent for all loggers and so is unlikely to be because the radiant electric heaters affected some of the loggers although they may have further heated the warm air which moved past them. The

diurnal and nocturnal changes can be observed and although the cooling down period is longer than the warming up period, it does not appear that the warm air blower is heating the walls of the building to any significant event and so the effects of thermal mass would appear to be minimal.

The internal T readings do follow the external T readings although the internal readings do not fall below circa 10°C even when the outside T is as low as 7°C this being because of the ambient thermal mass of the building. The fact that the background T is about constant at between 10 to 14°C while peaks of over 20°C are not uncommon, albeit for short periods, would suggest that if this system is cost effective to run, it is a model that others might be advised to use. Little energy appears to be wasted in heating the building fabric. This cathedral shows the traditional characteristics of radiant heating namely relatively low ambient heat, in this case circa 11°C early morning, and the rapid rise and fall of T readings.

The system was not in operation during any of the visits to the cathedral and so the issue of noise could not be assessed. If the system is noisy then it may not be able to be employed during services and, as the rate of egress of the warm air appears slow enough, the ambient T should remain high enough for thermal comfort during a service.

A typical profile for 4 days is shown in Figure 5.58 from Logger 11 and the readings are from 28th February 2016. Mass would have taken place every day at 10.30am. It can be observed that at about 10am there is a sharp rise in T from circa 10°C to just under 24°C by midday for this logger. The heat then drops quite quickly until 5pm and then more slowly until 6am the following day when it is back down to about 10°C. RH reacts as expected by falling rapidly with T increase and then rising slowly as a mirror image of the heating. The other loggers follow a similar pattern which confirms that the behaviour is not anomalous or local to the blower outlet. No other cathedral has this remarkable heating and cooling profile suggesting it is the hot air blower which dominates the temperature response, not the radiant heaters.

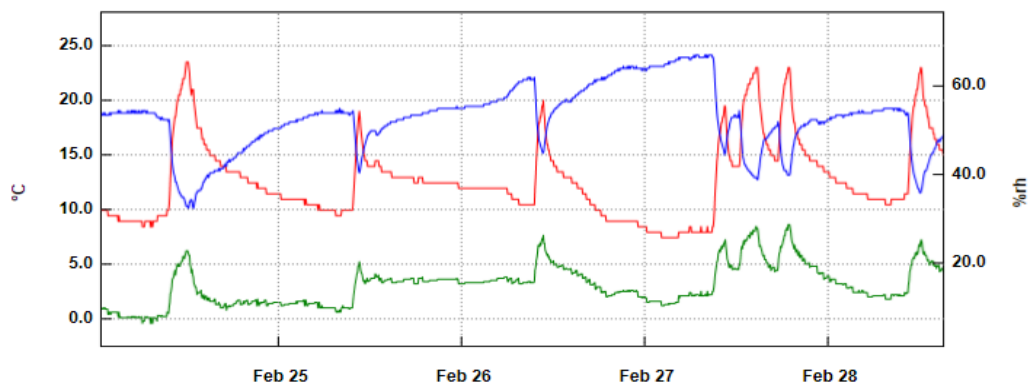

Figure 5.58 - St. Mary's cathedral, Cork, Logger 11, from 24 to 29 February 2016

The 28 February 2016 was a Sunday but the service on Saturday evening is also very important in most Catholic cathedrals and so the heating would have been turned on for that and then turned on

again on the Sunday. It appears from the graph that there may have been three services on the Saturday because the heating was turned on for three separate and quite short time periods on that evening.

Moisture

The consolidated RH readings are shown in Figure 5.59 and again show great consistency. The internal moisture readings mirror the T readings with similar sharp rises and falls. In addition, the external RH readings are not believed to be reliable enough to comment upon them, as the TinyTag, as previously stated, was not in an ideal position and the RH are unusually high for a prolonged period.

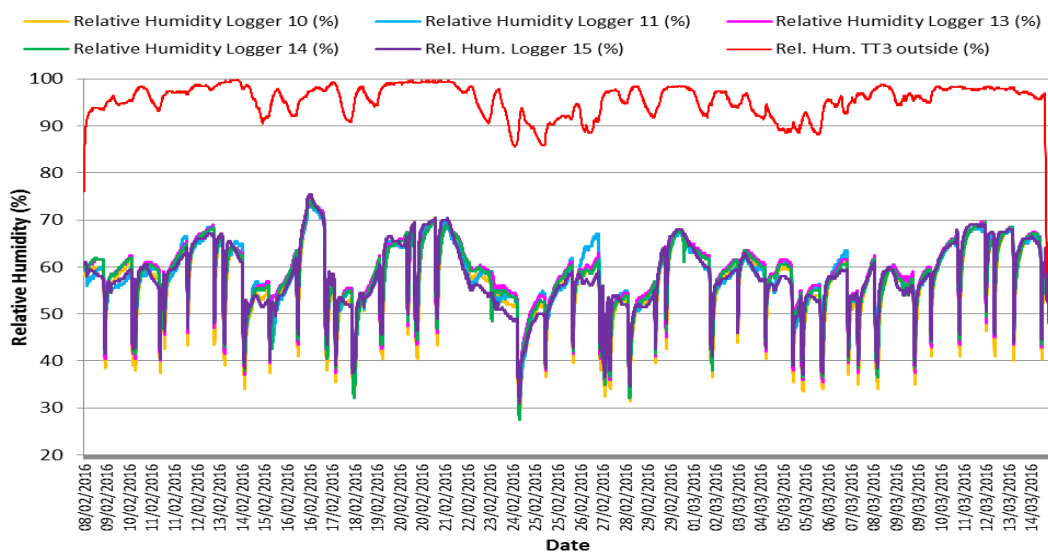

Figure 5.59 - RH readings inside and outside St. Mary's Cathedral, Cork

The internal RH readings do not exceed 70% and rarely fall below 40% which is an ideal regime for the protection of the building and its contents. The warm air blower must be on for short periods and when switched off the warm, low RH, air disperses quickly and so the interior of the building is not being dried out by these large volumes of warm air which are being pumped in over a relatively short period. In spite of the outside RH being apparently very high, the inside RH is not, which also implies that the building is well sealed and that ingress and egress of air is slight.

The loggers in this cathedral were ideally placed in the nave and the hot sir blower system clearly provides adequate levels of thermal comfort although the RH readings are very low at times but they are only low for a short period and therefore may not adversely affect the preservation and conservation of the building and its contents.

St. Columb's Cathedral, Derry and St. Patrick's (CI) Cathedral, Armagh

These two (CI) cathedrals are very different in age with St. Columb's being over 300 years older than St. Patrick's. In both cases previous churches had been built and destroyed many times on these

sites. They both have similar construction with solid stone walls, wooden ceilings, tiled roofs and single glazed windows. The floors are a mixture of wood, tiles and stone flags. Since both cathedrals are owned by the Church of Ireland their usage patterns for services are similar but they are both tourist attractions as well as cathedrals and so are open daily to visitors. Minor said services are held during the week but the main services, for both cathedrals, are held on Sundays. Both cathedrals have shops contained within them but the shop in Armagh is contained within a separate wood and glass area at the West end of the nave. Both cathedrals are in exposed situations with the one in Armagh being on top of a hill near to the centre of the city and that in Derry being on top of the city walls.

The positions of the loggers and TinyTag are illustrated in Figure 5.60 below.

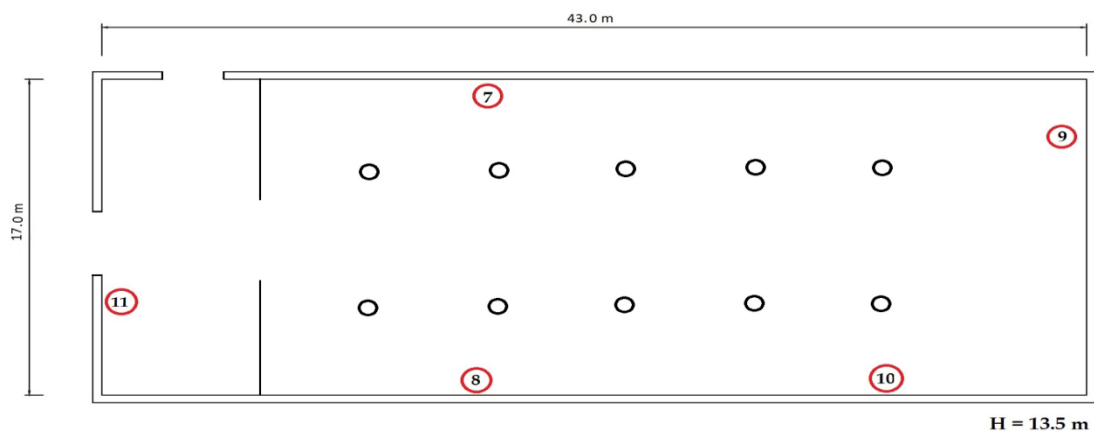

Figure 5.60 - Floor plan St. Columb's cathedral, Derry

Temperature

The reason why these two cathedrals can be considered together is explained when considering Figure 5.62 and Figure 5.63 which show the combination T readings from the loggers in Derry and in Armagh, respectively. In both cases it can be observed that the heat is turned on intermitently with fast warm up time and much slower cooling down which indicates that the heating is on for sufficient time and at a sufficient T to heat the building and hence to activate the thermal mass of the buildings. However much of the heat generated in both cathedrals is wasted because there are no services while the cathedral is still warm. In the case of Armagh cathedral and during the period from 15th November until 21st November what is particularly noticeable is that the building slowly cools down until the heat is turned on again on 22nd November.

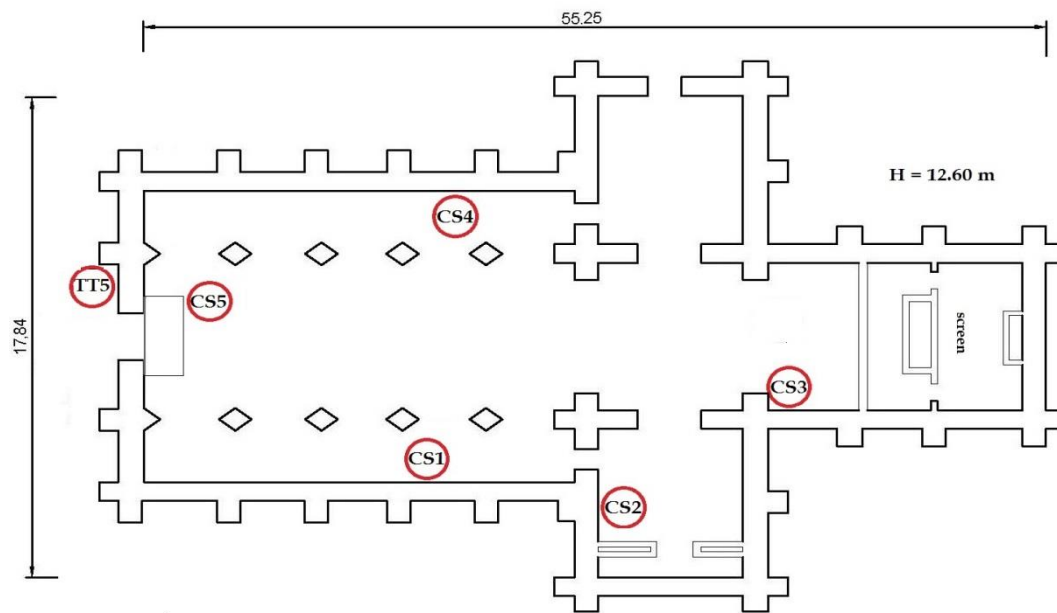

Figure 5.61 - Floor plan Armagh

The same thing happens in Derry, for example from 10th to 14th November where there is a sharp increase in T followed by a slow cooling off with the resultant waste of energy. In addition it should be noted that both cathedrals are raising the internal T by between 7 and 8°C in a short period of time which indicates that the boilers in both cathedrals are powerful enough to achieve this. Both cathedrals have LPHW systems but Derry is supplemented with an under pew hot air blower system in one part of the cathedral. The Tiny Tag in Armagh was not in an ideal position being just inside the unheated West door but there is a trend whereby the inside T follows the outside T and the boiler is powerful enough to bring the T back up to 16°C or so when required (or 19°C in the case of Derry). There was no extended period of very cold weather to be able to judge if the boiler was set to come on for a particular time or was set to achieve a particular T reading. In the case of Derry, sharp and large T rises from about 11°C up to over 19°C are rapidly achieved and the heating system seems quite capable of achieving high internal T readings and does not usually follow the outside T readings. The question posed for both cathedrals is whether it is better to apply large amounts of energy on an intermittent basis to raise the T by some 8°C (with subsequent inefficiently long cooling periods) or is it more cost effective to keep low level heating on constantly to achieve conservation levels of heat at around 11 to 12°C and then boost the heat to bring it up to around 18°C for the short period required for the service. Without the necessary financial data it is not possible to adequately answer this question.

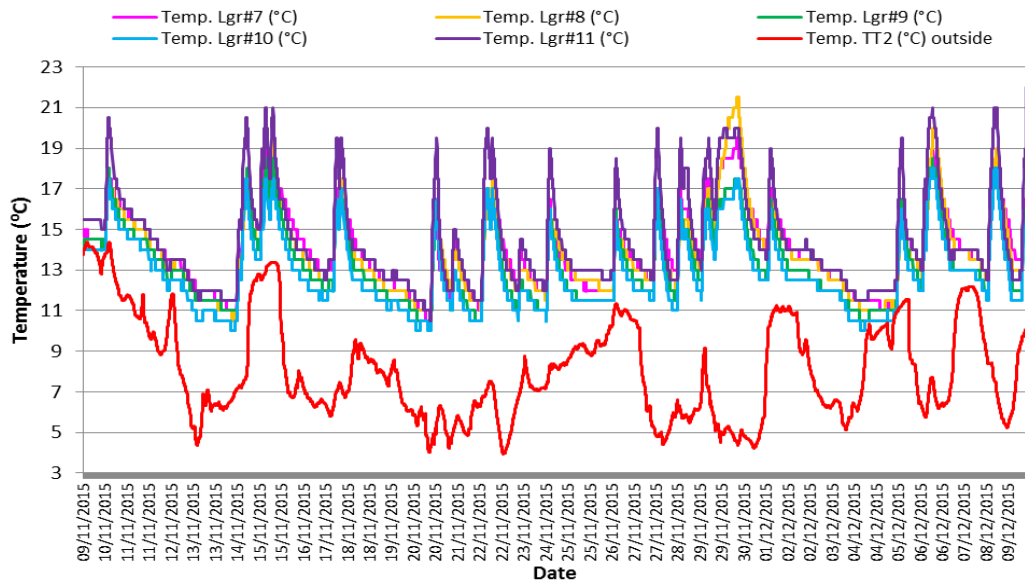

Figure 5.62 - Consolidated T readings (inside and outside) for St. Columba's Cathedral, Derry

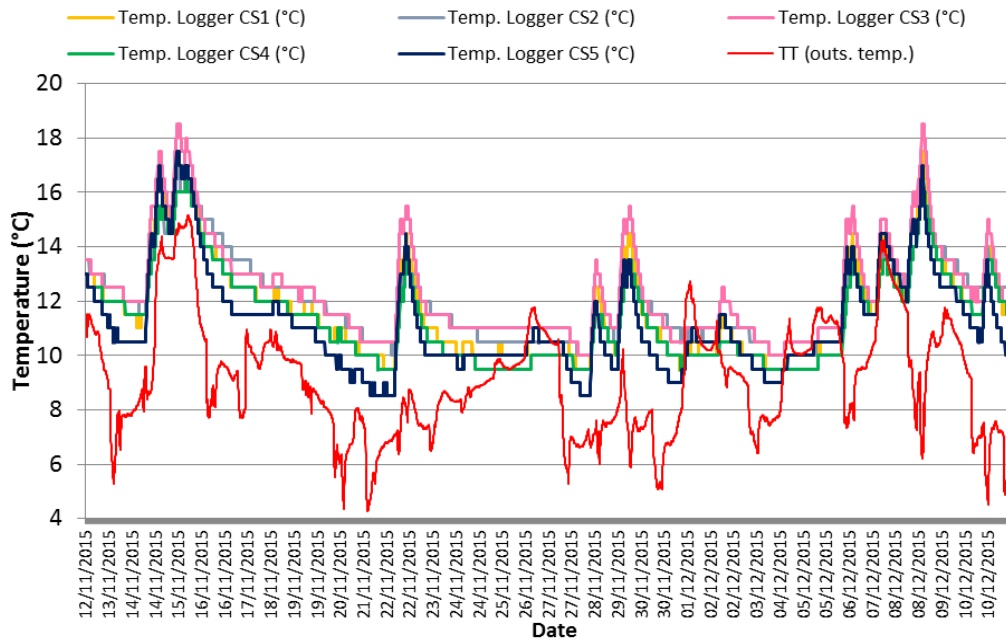

Figure 5.63 - Consolidated T readings for St. Patrick's Cathedral (CI) in Armagh

Moisture

The outside RH readings from Armagh, where the TinyTag was inside the West door, are not considered to be reliable enough to use. In the case of Derry whilst the figures were volatile they do have a correlation with the outside T readings. The particularly high readings on 5th December as shown in Figure 5.64, were unusual since both T and RH rose as a result of their being a large service that day and the weather was very wet

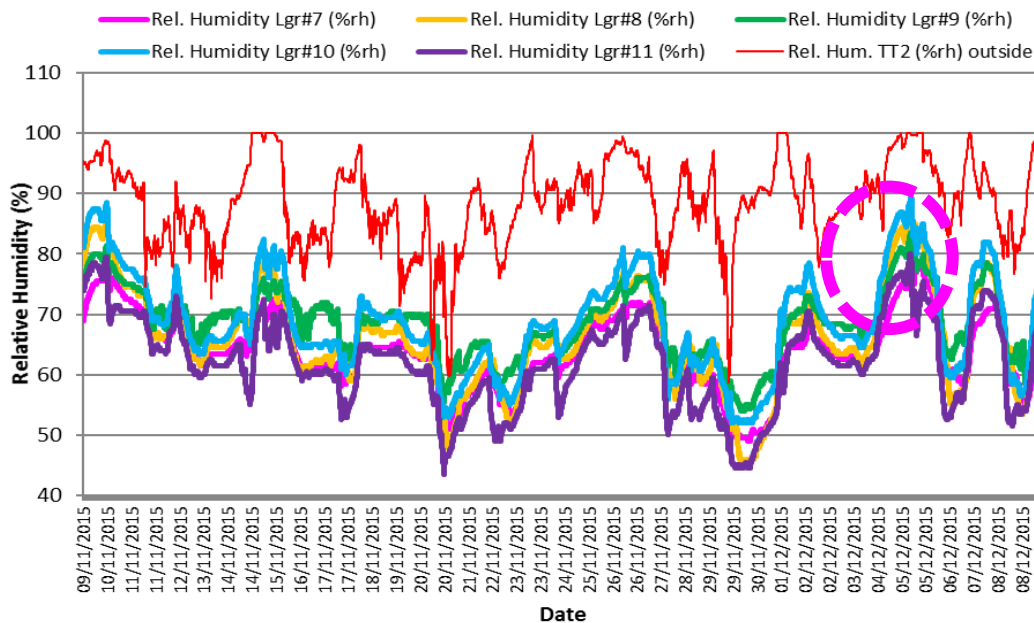

Figure 5.64 The effect of a large number of people entering the cathedral for a service on 5 December in St. Columb's cathedral, Derry (CI), when the weather was very wet.

Derry cathedral provides an adequate level of thermal comfort on Sundays but much of this heat is wasted during the week. Armagh cathedral does not provide adequate levels of thermal comfort, even on most Sundays. The locations of loggers in both cathedrals would ideally have been in the nave but this was not possible for practical reasons.

St. Peter's Cathedral, Belfast and St. Fin Barre's cathedral, Cork.

These two cathedrals, although situated at almost opposite ends of the island have a number of similarities. They are both approximately the same size being 15,000m³ and 19,400m³ respectively and they are similar in age with St. Peter's (RC) being consecrated in 1866 and St. Fin Barre's (CI) in 1870. Both have similar construction with solid stone walls, wood and tiled floors, single glazed stained-glass windows and traditional tiles roofs. Both have LPHW heating systems with St. Fin Barre's being supplemented with trench heating. St. Fin Barre's receives considerable numbers of tourists each year and has a small shop area adjacent to the welcome desk inside the West door. St. Peter's is a traditional city centre RC cathedral which receives few visitors but is in regular use by worshipers. Both cathedrals are open every day. St. Fin Barre's is unusual in having the organ situated on and below floor level as shown in Figure 5.65.



Figure 5.65 - Organ in St. Fin Barre's (CI) cathedral, Cork

Also in Cork a picture taken with the FLIR camera, as shown in Figure 5.66, appeared to show that when the heating was on, no heat could be seen coming from the underfloor heating but the trench heating was clearly active.

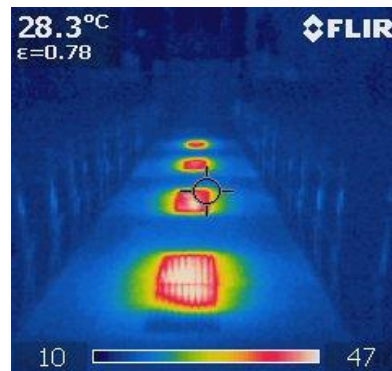

Figure 5.66 - St. Fin Barre's cathedral, Cork. Trench heating

The cathedral manager did not think that the heating could be zoned to switch off the underfloor heating when the trench heating (LPHW) system was on, but the evidence is that this was not the case. The area under the pews, where the underfloor heating is situated, was covered in wood which may have limited the effect of this heating, but further research is required to clarify this situation. If in fact the underfloor heating has been insulated in some way then this might signify that a considerable amount of energy is being wasted but it is surprising that no heat appears to emanate from under the pews.

Temperature

St. Peter's and St. Fin Barre's cathedral both have underfloor heating systems and for comparison the relevant consolidated T readings are shown in Figure 5.67 and Figure 5.68.

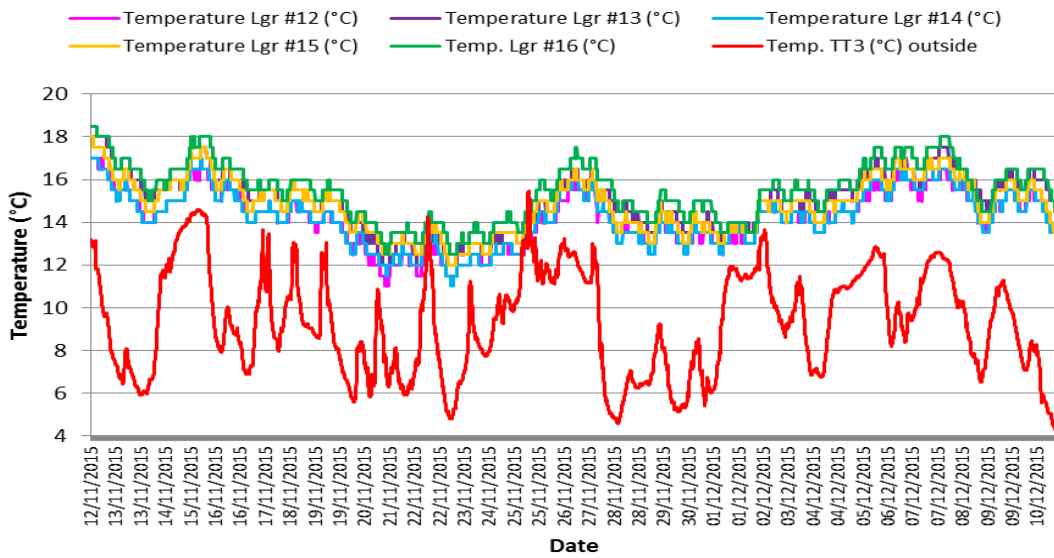

Figure 5.67 - Consolidated T readings for St. Peter's cathedral, Belfast

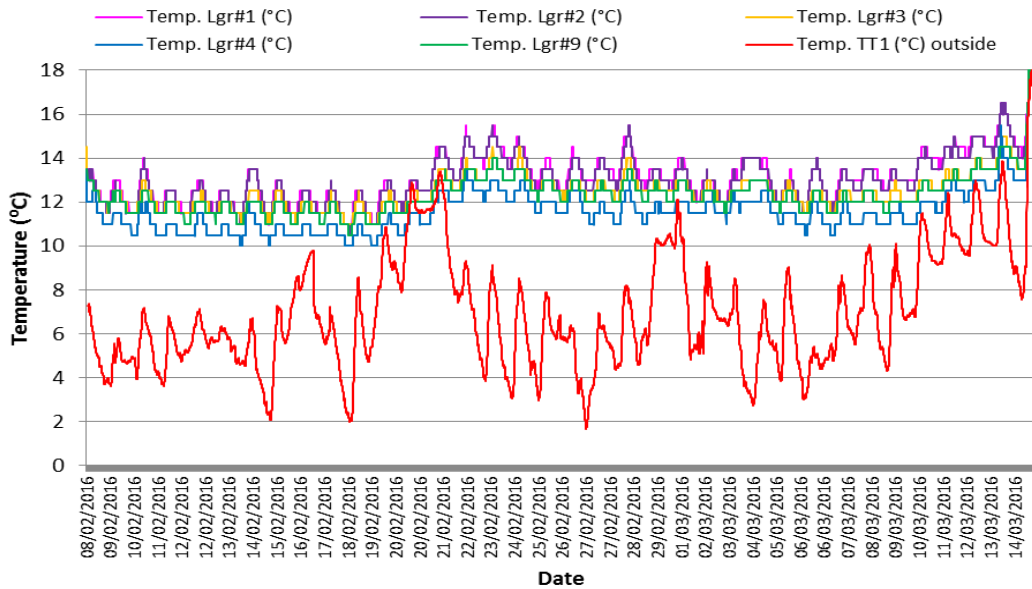

Figure 5.68 - Consolidated T readings for St. Fin Barre's cathedral in Cork

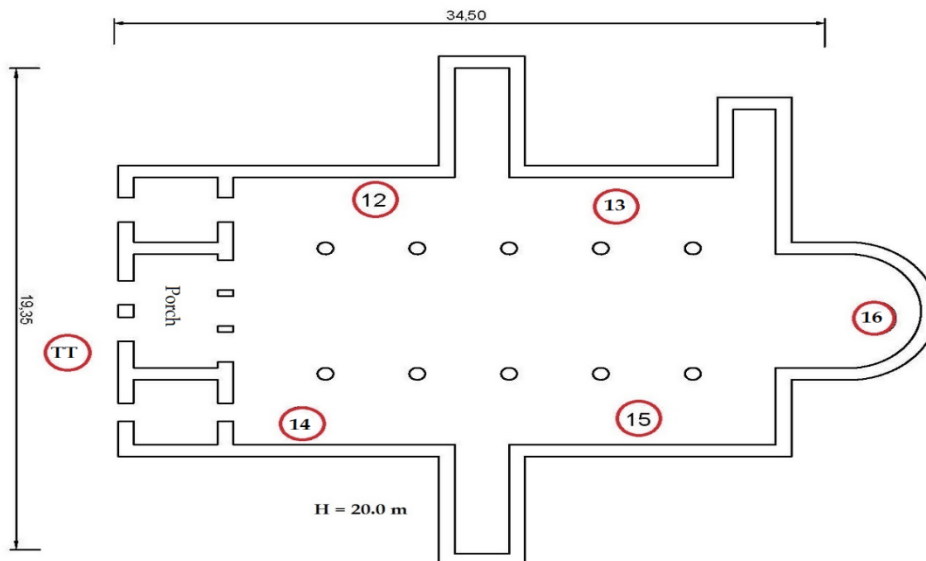

Figure 5.69 - Floor plan St. Peter's cathedral, Belfast

The profiles shown in Figure 5.67 and Figure 5.68 are typical of an underfloor heating system with small changes in T and uniformity throughout the building. Comparing the T readings from St. Fin Barre's (Figure 5.68) and St. Peter's in Belfast (Figure 5.67), Figure 5.16 (Galway), Figure 5.38 (Limerick CI), Figure 5.43 (Killarney) and Figure 5.50 (Longford), there is an unmistakable signature profile for this type of heating system. If Armagh (RC) cathedral used its underfloor system then it would also display this profile.

Both cathedrals have fairly stable internal T readings with Cork ranging from 10°C up to circa 16°C and Belfast (RC) ranging from circa 12°C to 18°C. Both systems are influenced by the outside T and yet manage to maintain reasonable ambient background T readings of circa 12°C in Cork and circa 15°C in Belfast against outside temperatures of circa 3-12°C in both cases. Any difference may be because Belfast has decided to maintain, by choice, a higher ambient T which means that the boilers are on for longer or are more powerful. Both cathedrals have the characteristics of underfloor systems which are an even spread of warm air throughout the buildings, stable ambient T readings and small changes.

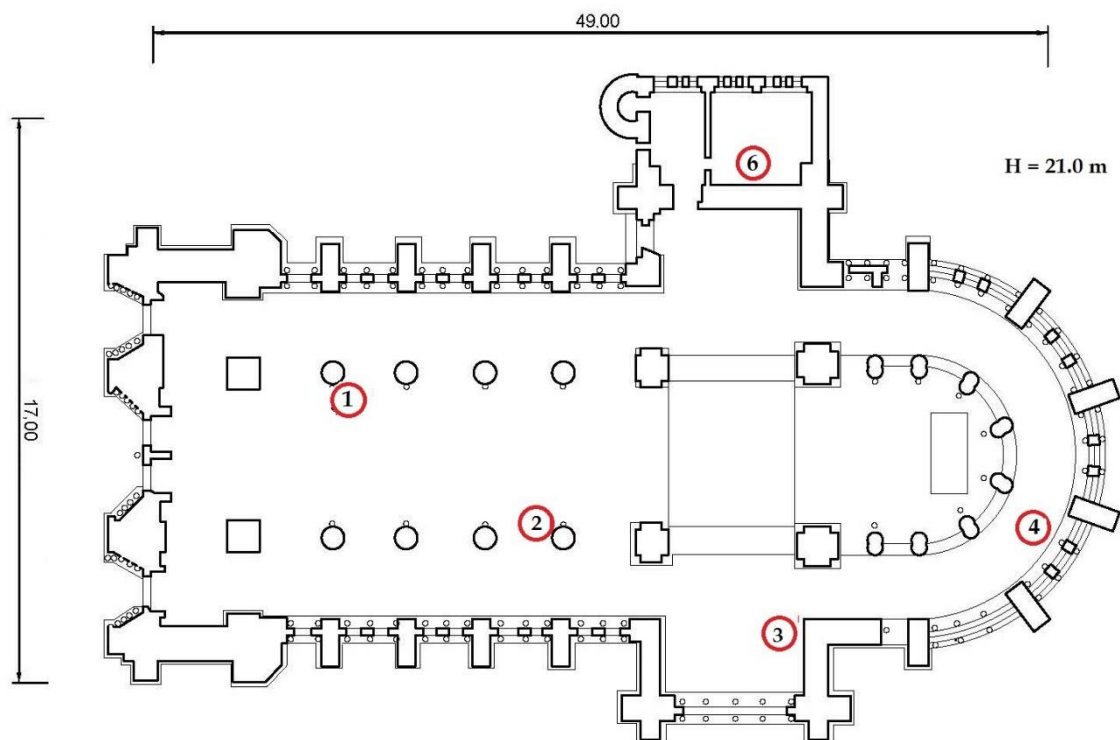

Figure 5.70 - Floor plan St. Fin Barre's cathedral, Cork

The rate per hour increases are shown in Figure 5.71 for Cork and in Figure 5.72 for Belfast (RC).

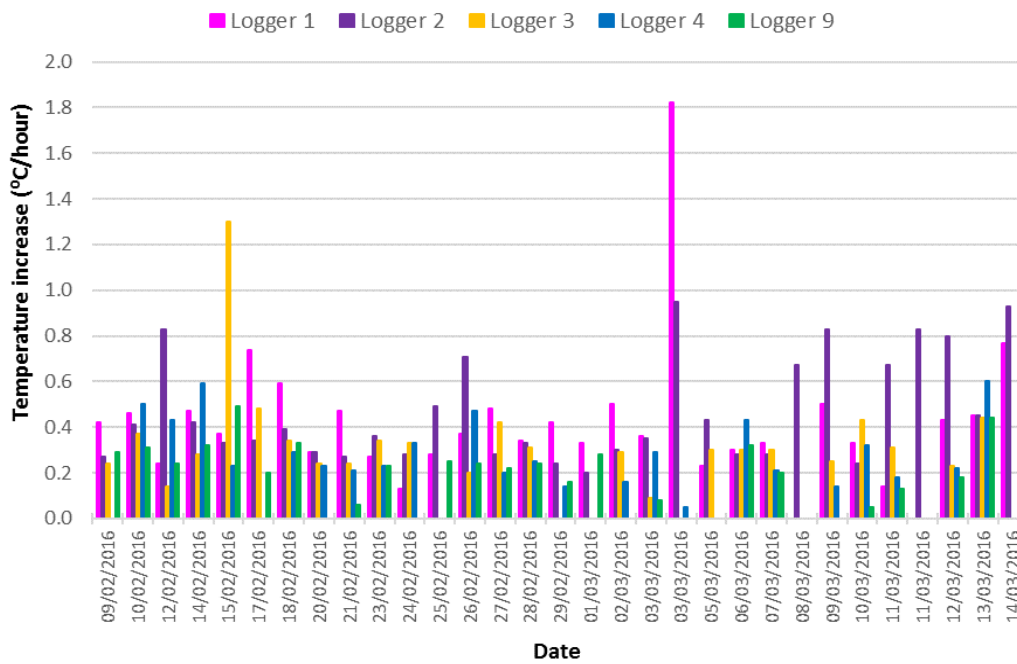

Figure 5.71 - Rate of temperature increase per hour in St. Fin Barre's Cathedral, Cork

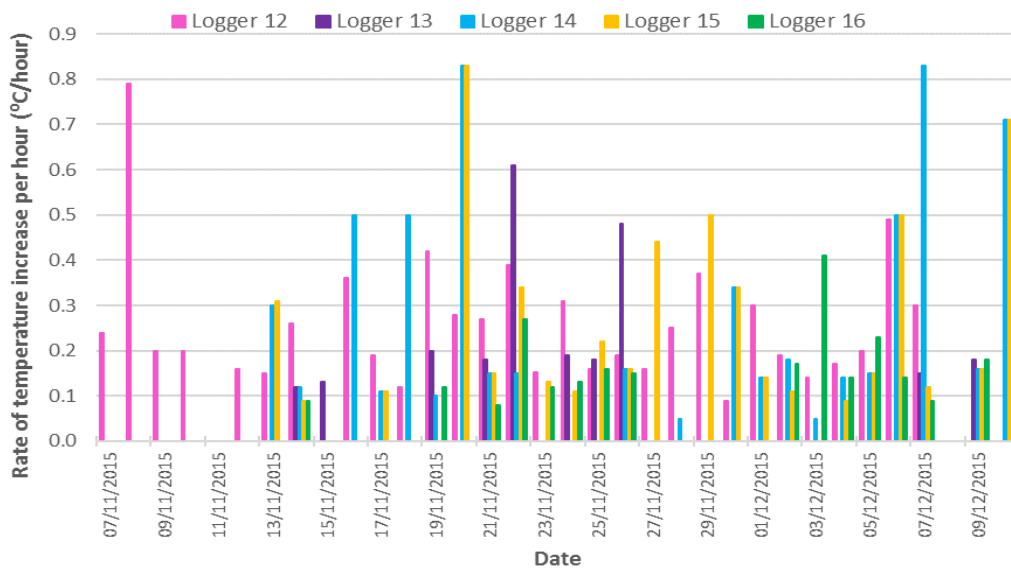

Figure 5.72 - Rate of T increase per hour in Belfast St. Peter's cathedral

Both cathedrals show low rates of increase of between 0.10 and 0.25°C per hour which again is typical of underfloor heated cathedrals. Therefore, these two buildings were highlighted because they display typical characteristics for this type of heating. Small changes in T are generally good for the building and its contents.

Moisture

The RH consolidated graphs for Cork are shown in Figure 5.73 and for Belfast in Figure 5.74.

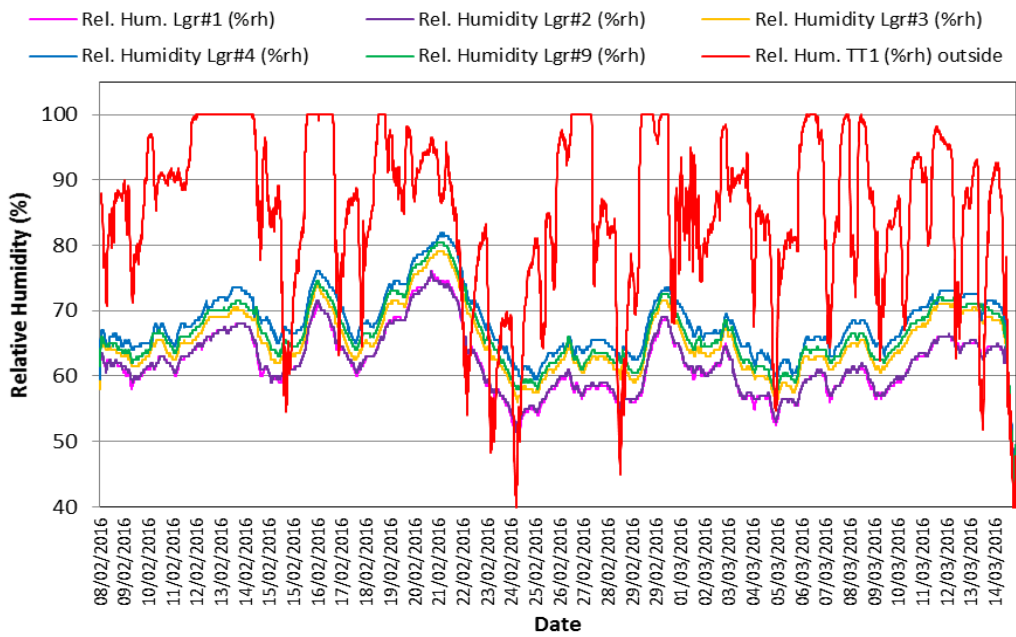

Figure 5.73 - Consolidated RH readings (inside and outside) for St. Fin Barre's Cathedral, Cork

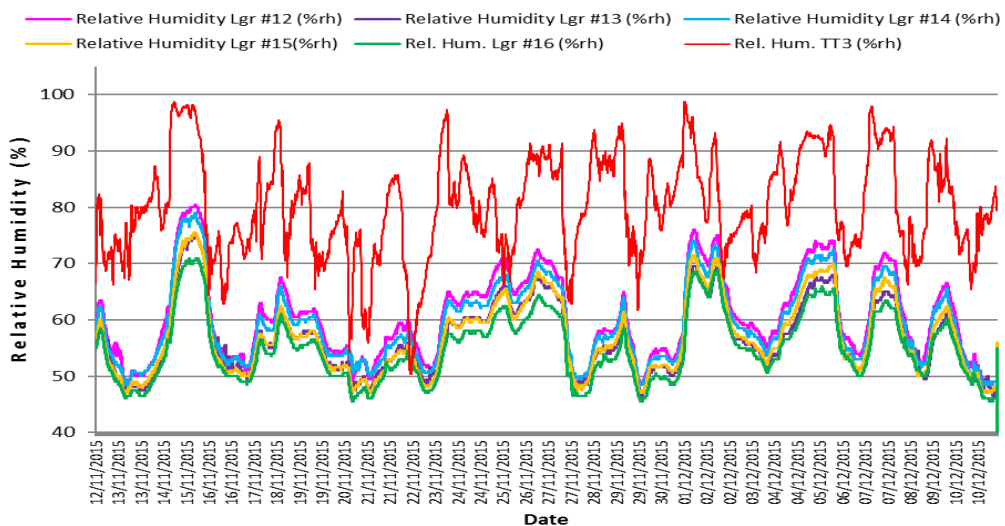

Figure 5.74 - Consolidated RH readings for St. Peter's Cathedral, Belfast

It can be observed that both cathedrals are influenced by and follow the outside RH figures, implying infiltration but that both are reasonably stable over time (because T values vary slowly) with a range of between around 50% and 80% RH in both cases. The 80% was a peak in both cathedrals and would be at a level likely to encourage mould but the ambient RH in Belfast is around 60% and in Cork 65% which are within the boundaries which would not adversely affect the buildings or their contents (Bordass and Bemrose, 1998). Reasonably stable T readings produce reasonably stable RH for well-sealed buildings readings and these RH trends are again fairly typical for these heating systems, which is why these two cathedrals were examined together.

Christ Church Cathedral, Dublin

Christ Church is one of Dublin's oldest buildings and it is probably the oldest cathedral in Dublin although it was extensively rebuilt in the late 1880s. The oldest surviving part of the cathedral still

standing is the North transept which dates to the 1300s. The cathedral is built traditionally of solid stone walls, with a stone ceiling, tiled floor and single glazed stained-glass windows. There is no insulation in the building. The cathedral contains a large pipe organ which is used regularly. The cathedral also, uniquely, contains a valuable treasury which is situated in the crypt, the crypt itself being large considering the size of the cathedral and is certainly large by Irish standards. The treasury contains many intrinsically and monetarily priceless artefacts but they are mostly contained in environmentally controlled show cases. What makes this cathedral unique from a heating and energy use perspective, and the reason it was chosen to be monitored, is that it is the only cathedral in Ireland which is part of a district heating system.

In the 1970s when Dublin City Council built new civic offices, they installed a joint heat and power unit in the basement of the offices. This gas-powered unit produced excess heat which the Council sold, at minimal cost, to a number of surrounding buildings, including the cathedral. The offices are situated approximately 100 m from the cathedral. Subsequently the Council installed two gas boilers, as shown in Figure 5.75, for their own use but continued to supply the cathedral with heat. The offices have, in the last few months, installed a separate boiler just to supply heat to the cathedral but it is not known if they still supply heat to other buildings in the area.



Figure 5.75 - Civic offices boilers which supplied heat to Christ Church cathedral, Dublin

The disadvantage for the cathedral in this system is that the cathedral has no control over either the level of heat coming into the cathedral, except by turning radiators on and off, or the times when it is on or off, as this is decided by the utilities manager in the civic offices. Also the amount of heat loss from the boiler to the cathedral is not known and since the original pipe work was installed in the 1970s, this could be substantial. The cathedral uses an LPHW system with pipes and radiators as well as heating pipes in trenches as shown in Figure 5.76.

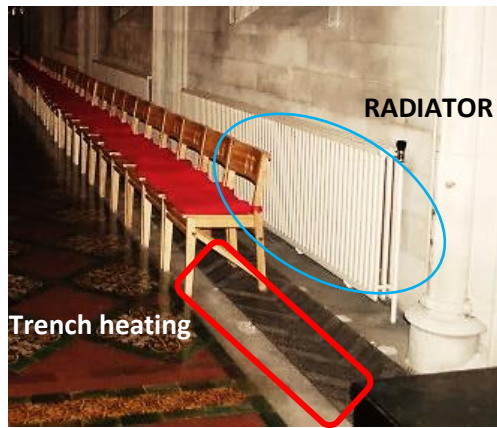

Figure 5.76 Christchurch cathedral, LPHW heating system with radiators and heating pipes in trenches

The position of the loggers in winter in the Christ Church are shown in Figure 5.77 below.

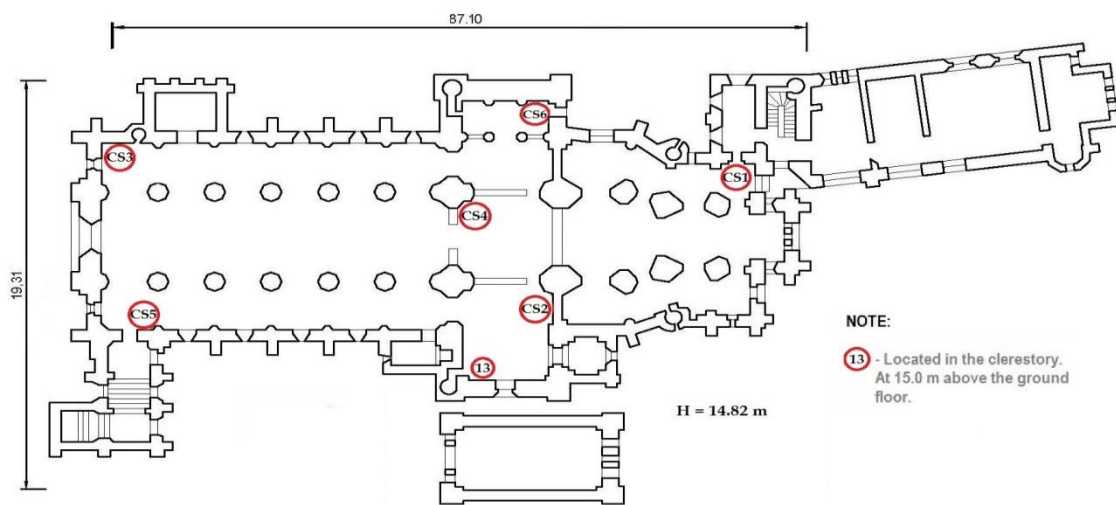

Figure 5.77 CCC floor plan, Dublin

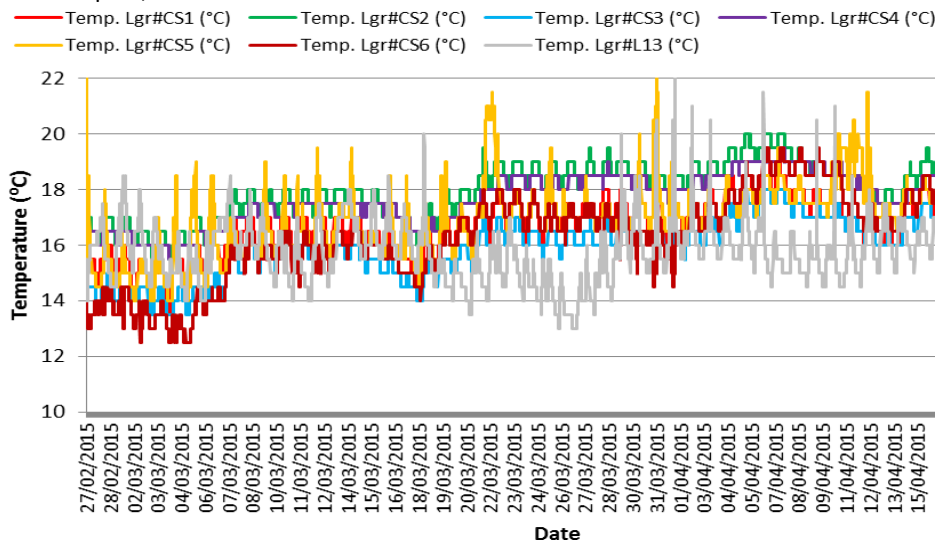

Figure 5.78 - Consolidated internal T readings in Christ Church cathedral, Dublin in winter

The reason why there is such a range and difference is probably because of inefficiencies in the pipe work and radiators but may also have something to do with the locations of the loggers. This LPHW profile is completely different to the profile of an underfloor system observed previously. Daily

variations are higher and faster, though the range is controlled, at 13°C - 19°C approximately despite low external temperatures (Figure 5.79).

The TinyTag readings are shown separately in Figure 5.79 because this unit was inadvertently set to record every 15 minutes rather than every 5 minutes like the loggers. This did not invalidate the data and the TinyTag was in an ideal location in the belfry of the cathedral.

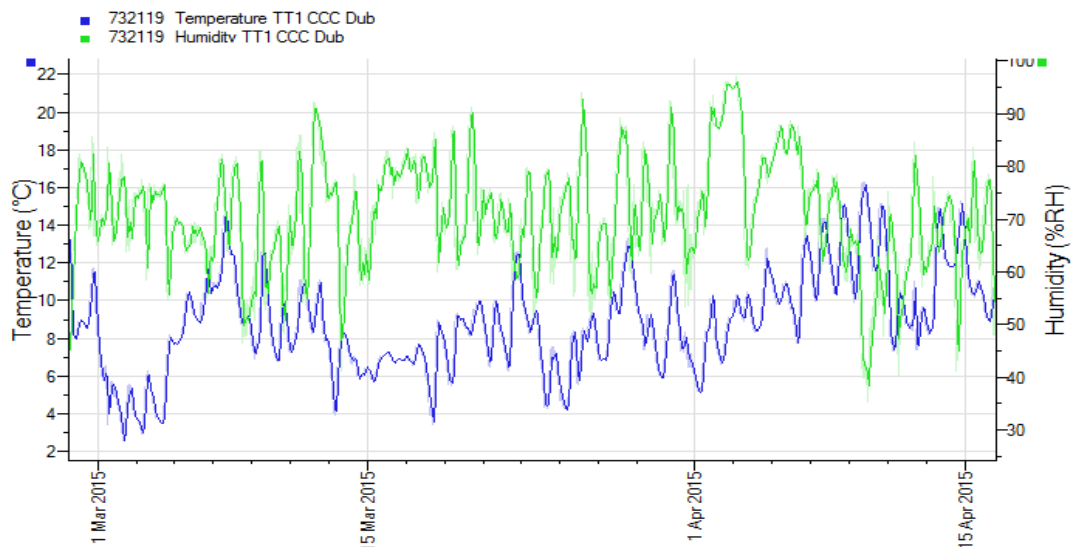

Figure 5.79 - TinyTag readings for Christ Church cathedral Dublin in the winter

In spite of having no control over the heating, a number of things can be observed. Firstly the fact that the internal T readings generally follow the outside T readings suggests a building envelope which allows easy ingress and egress of air. Secondly with perhaps the exception of Logger CS5 which was located near to artificial heat provided for the comfort of the welcome desk staff, the loggers show a reasonable level of equality throughout the building. Logger 13 was set at the level of the clerestory to establish if stratification was present in this cathedral and it appears that it is not, or else the level of infiltration at this level is very high. Also the ambient T is quite high at circa 17°C compared to circa 8°C outside. The heating is on every day, similar to the nearby St. Patrick's cathedral, and so the T rises required each day are small. The T readings shown for St. Patrick's cathedral in Figure 5.4 also show a level of dispersion which again suggests a high level of infiltration. The larger size of St. Patrick's does not appear to be an influence. Both cathedrals have the heating on every day for the heating season which is why the ambient readings are high. This cathedral was monitored between March and April and so the outside T would be expected to be generally higher than earlier in the year. However, the outside T fluctuated from as low as 2.5°C to a high of 16°C with some days when the T did not get above 8°C. Thus the time of year is less likely to be a factor in the higher average internal temperatures.

Moisture

The consolidated graph for the RH readings in the winter, are shown in Figure 5.80 and a degree of uniformity can be observed. Logger 13 in grey shows a higher level of RH than the other loggers because the infiltration rate at the clerestory level is higher than at the level of the other loggers which was around 2m. The location of the loggers is obviously of importance in this case.

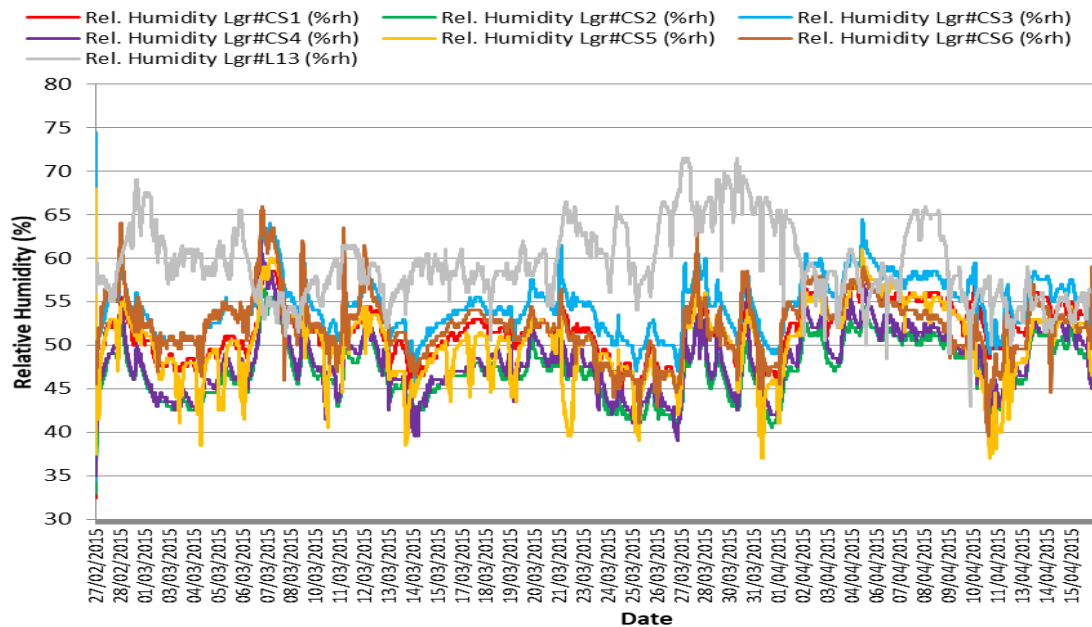

Figure 5.80 - RH readings for Christ Church cathedral, Dublin during Winter 2015

The range of between 40% and circa 60% would not damage the building or its contents. These readings are quite low and are most likely a result of the relatively high internal ambient T readings of circa 17°C.

5.3.2 Medium Cathedrals not monitored

Some details of these cathedrals can be found in Table 5.3 and in Chapter 4. Nine of the remaining cathedrals are owned by the Roman Catholic Church and two by the Church of Ireland. The CI cathedral in Cloyne only has one service per week for approximately 10 to 20 people and relies on electric night storage heaters to provide heating. There is evidence of an older LPHW system in the cathedral. Regrettably this cathedral is too far from a tourist trail to benefit from tourist income and the future of the cathedral must be uncertain. The other CI cathedral in this group, namely the one in Waterford, is in the heart of this thriving city and is open every day having one service per day and two on Sundays. The cathedral installed four condensing gas boilers in 2014 which reduced their fuel consumption by a third. The heat is on every day and, unlike most cathedrals, it is thermostatically controlled to keep the ambient T at between 12 to 14° by means of an LPHW trench system of heating. It should not be considered somehow dismissive to categorise these unmonitored cathedrals together since they are each unique with many interesting architectural features. They do have a number of similarities however. They are largely situated in rural Irish towns. They are

different architecturally except that both the cathedrals in Waterford had the same architect, namely John Roberts (1714-96) (Galloway, 1992). The RC cathedral in Waterford is surrounded on three sides by other buildings, the protection from which may give rise to more equilibrium in the internal environment than, for instance, the other (CI) cathedral in the city, which is more exposed as shown in Figure 5.81.



Figure 5.81 - The two Waterford cathedrals, with one exposed (CI) on the right and the other (RC) on the left surrounded on three sides by other buildings

It was not possible from the data collected to establish the extent to which surrounding buildings influence the internal environment in a cathedral and further research would be needed to establish what effect, if any, the degree of exposure has on the relevant cathedrals.

All of these medium sized cathedrals are open every day although, except for Waterford, they would not experience much tourist traffic. They all employ LPHW heating systems. Letterkenny cathedral was in the process of replacing its one large oil boiler with two smaller oil boilers at the time of the visit. Figure 5.82 shows the old oil boiler at the rear with the two new oil boilers being connected, in the foreground.

The cathedral is also installing a Building Management System (BMS) to control the environment within the building but regrettably the sacristan did not have details of this installation.



Figure 5.82 - New oil boilers being installed in Letterkenny cathedral

BMS are not common at all in Irish cathedrals and Letterkenny is one of the few which is known to have or are about to install one. In future research it may be informative to visit the cathedral to evaluate how this BMS has affected the T regime.

5.3.3 Key findings for medium cathedrals

The distinctive features of the medium cathedrals are:

- Another diverse collection of buildings and heating systems.
- 11 of 18 cathedrals have LPHW systems with a further 4 having LPHW augmented with another system.
- The hot air blower system in Cork (RC) produced the highest rate of heating of any cathedral.
- None of these cathedrals is known to have any insulation.
- The older cathedrals tend to have a higher level of infiltration.

Many of these findings apply to both very large and large cathedrals but the figures produced by the hot air blower system definitely require further research.

5.4.1 Small Cathedrals

Small cathedrals have been classified as those which are smaller than 10,000m³ and there are 24 cathedrals in this group, which represents 42% of the total of 57. Many of the small cathedrals are situated in small rural towns with the smallest, namely Kilfenora in Co. Clare, being 1,060 m³ in size and situated in the village of Kilfenora, which has a population of 700 people. (www.kilfenoraclare.com, 2017). Of these 24 small cathedrals, it was decided to monitor 9 or 38% as this was thought to be a representative sample of the whole. The monitored cathedrals were chosen by considering their locations, usage, heating system and availability for monitoring. They had all been previously visited and the questionnaire completed so that an opinion could be formed as to their suitability. Details of the small cathedrals are presented in Table 5.4.

Table 5.4 Small cathedrals (smaller than 10,000 m³), showing age, heating type and fuel used

City	Name	Size (m ³) approx.	Age	Heating type	Fuel
Downpatrick	Down Cath. Holy & Undiv. Trinity	9,700	1818	LPHW	Oil
Carlow*	Cathedral of The Assumption (RC)	9,000	1833	LPHW	Gas
Tuam	St. Mary's (RC)	8,000	1837	LPHW	Oil
Loughrea*	St. Brendan's (RC)	7,700	1902	LPHW	Oil
Kildare*	St. Briget's (CI)	7,500	1686	LPHW	Gas
Ennis	St. Peter & St. Paul (RC)	7,300	1843	LPHW	Oil
Skibereen*	St. Patrick's (RC)	5,400	1826	LPHW	Oil
Lisburn	Christ Church (CI)	5,300	1804	LPHW + radiant	Oil
Dromore	Christ The Redeemer (CI)	4,500	1899	LPHW	Oil

City	Name	Size (m ³) approx.	Age	Heating type	Fuel
Lismore*	St. Carthage's (CI)	4,300	1687	Radiant	Elect.
Killaloe*	St. Flannan's (CI)	4,140	1225	LPHW	Oil
Cavan/Kilmore	St. Fethlimidh's (CI)	4,000	1860	LPHW	Oil
Sligo	St. Mary & St. John (CI)	4,000	1961	LPHW	Oil
Enniskillen*	St. Macartin's (CI)	3,800	1842	Hot air	Oil
Cashel	St. John & St. Patrick (CI)	3,500	1788	LPHW	Oil
Rosscarberry	St. Fachtna's (CI)	3,200	1612	LPHW	Oil
Clonfert	St. Brendan's(CI)	2,700	1167	Radiant	Elect.
Trim	St. Patrick's (CI)	2,400	1955	LPHW	Oil
Clogher	St. Macartan's (CI)	2,350	1744	Under pew	Elect.
Raphoe*	St. Eunan's (CI)	2,200	1738	LPHW	Oil
Killala	St. Patrick's (CI)	2,025	1680	LPHW under pew	Gas
Ferns	St. Edan's (CI)	1,660	1577	Hot water pipes	Oil
Old Leighlin*	St. Laserian's (CI)	1,600	1290	LPHW / facade / ASHP	Oil/ASHP
Kilfenora	St. Fachtna's (CI)	1,060	1189	Underfloor	Elect.

*Note: monitored

A number of the monitored cathedrals have unique features which affect the internal environment of the buildings and which it is felt justify individual comment as follows:

Carlow (RC)	Town centre cathedral with high usage
Loughrea (RC)	As for Carlow but with tourism as well.
Kildare (CI)	Age of cathedral and of heating system
Skibbereen (RC)	As for Loughrea with tourism and high usage for a small cathedral
Lismore (CI)	Age and heating type, namely radiant
Killaloe (CI)	Age of building and heating system and tourism
Enniskillen (CI)	Prominent city centre cathedral with hot air blower system
Raphoe (CI)	Urban CI cathedral, low usage, intermittent heating
Old Leighlin (CI)	Very old cathedral with solar and air source heat pump

Five of the cathedrals which were monitored namely Carlow, Skibbereen, Killaloe, Raphoe and Loughrea were monitored in the spring but the heating in the cathedrals was still operating and Spring in Ireland can be as cold and damp as March.

Small cathedrals, as can be seen in Table 5.4 are mostly CI, which means that they are generally only open for one service a week on Sundays. Some which are in tourist locations, such as Killaloe, are open every day to visitors. Killaloe does not charge for entry and so visitor numbers are not known. The heating therefore in CI cathedrals, and this applies to many regardless of their size, will be

intermittent. Congregations for the Sunday service can be in single figures. Small RC cathedrals (although this applies to RC cathedrals irrespective of sizes), are open every day and usually have a service each day with perhaps two on Sundays. Again, the heating, regardless of the type, is often used intermittently. Numbers who use RC cathedrals are not known since people tend to come in and out during the day for private devotions and RC cathedrals, regardless of size, do not charge for entry, as already stated.

5.4.2 Monitored small CI cathedrals

The Church of Ireland monitored cathedrals namely, Lismore, Kildare Killaloe, Enniskillen, Raphoe and Old Leighlin tend to only have one service per week, have a variety of heating systems and some struggle to achieve a reasonable level of thermal comfort. Old Leighlin, and Kildare are open for visitors every day in the summer and offer guided tours. Lismore, Killaloe, and Raphoe are open every day throughout the year but the cathedrals are generally not attended by a member of staff. Congregations are small and the buildings are usually only heated for the weekly Sunday service.

St. Flannan’s Cathedral (CI) Killaloe and St. Eunan’s Cathedral (CI) Raphoe

The CI cathedrals of Killaloe and Raphoe behaved as expected as both are open daily with services on Sundays only) although Killaloe would receive more visitors since it is located in a tourist area. Neither cathedral charges for entry so visitor numbers are not known. The monitoring dates for all cathedrals can be seen in Table 3.3. Both of the cathedrals were still operating their heating systems during the monitoring period and showed the expected intermittent LPHW trends of quite a fast heating up time with slower cooling periods although Raphoe did cool down faster than Killaloe which suggests higher infiltration rates. Both cathedrals are open every day for visitors but only hold one service on Sundays.

The locations of the loggers in this cathedral are shown in Figure 5.83 below.

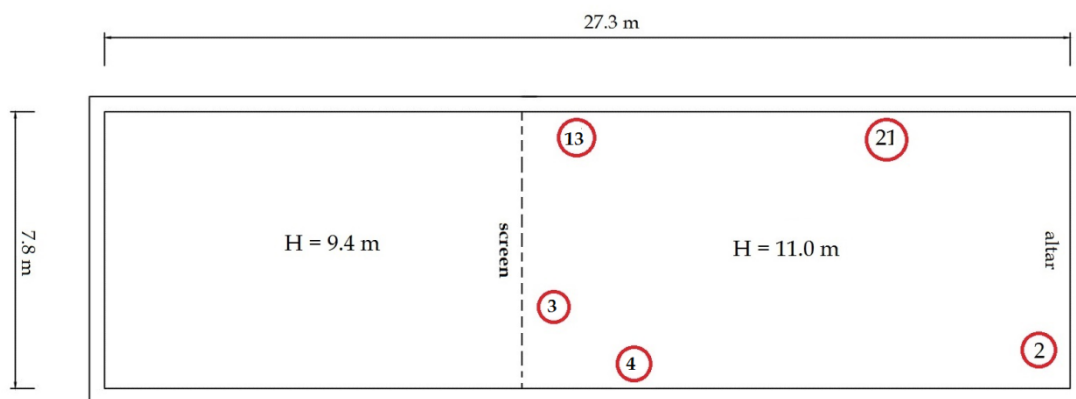

Figure 5.83 - Floor plan St. Flannan’s Cathedral Killaloe.

Figure 5.84 illustrates the consolidated T readings for Killaloe showing a typical intermittent LPHW heating profile. The heating manages a Sunday ambient T of between 15 and 17°C even with T as low

as 9°C outside, which is reasonable for thermal comfort. The hot water pipes run in front of the pews in this cathedral and this also helps to provide local heating to the occupants. Where the loss is slow, such as between 18th and 22nd March, there is some wasted energy.

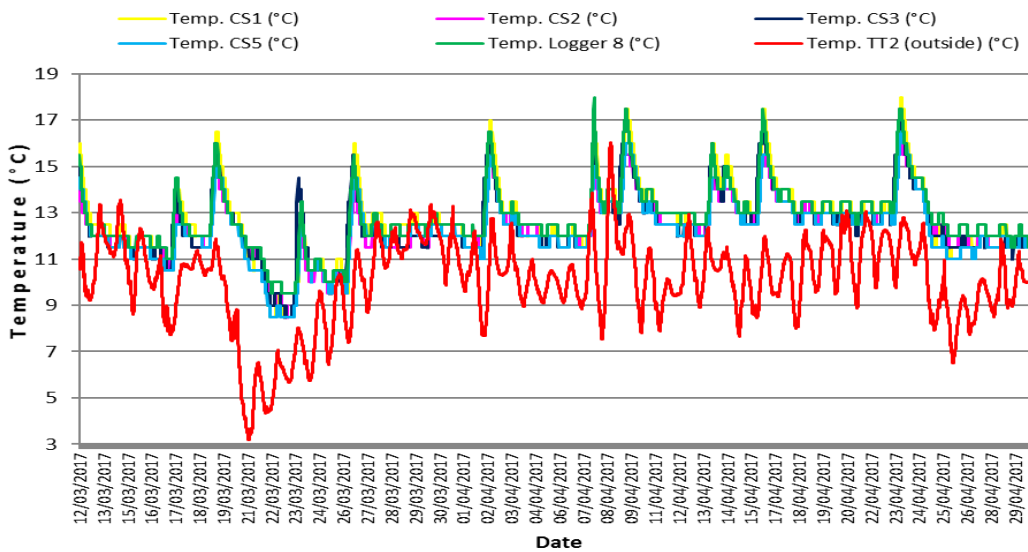

Figure 5.84 - Consolidated T readings for St. Flannan's CI cathedral (Killaloe)

The close way in which the background internal and external T readings reflect each other is clearly seen and implies that the building envelope is porous to exchanges of air. The heating is only turned on for Sunday services, which is evident from the peaks in T.

The rate increase per hour for the loggers for Killaloe is shown in Figure 5.85. The average of the rate of T increase in the church is consistently around 0.3°C per hour, which implies that the boiler may be undersized and that infiltration is an issue. This implies lengthy heat up periods to go from circa 12°C to 16°C Half of this cathedral is not used and is screened off and unheated and there may be substantial movement of warm air from the heated part to the unheated part since the screen, which reaches to the roof, is wood framed and single glazed.

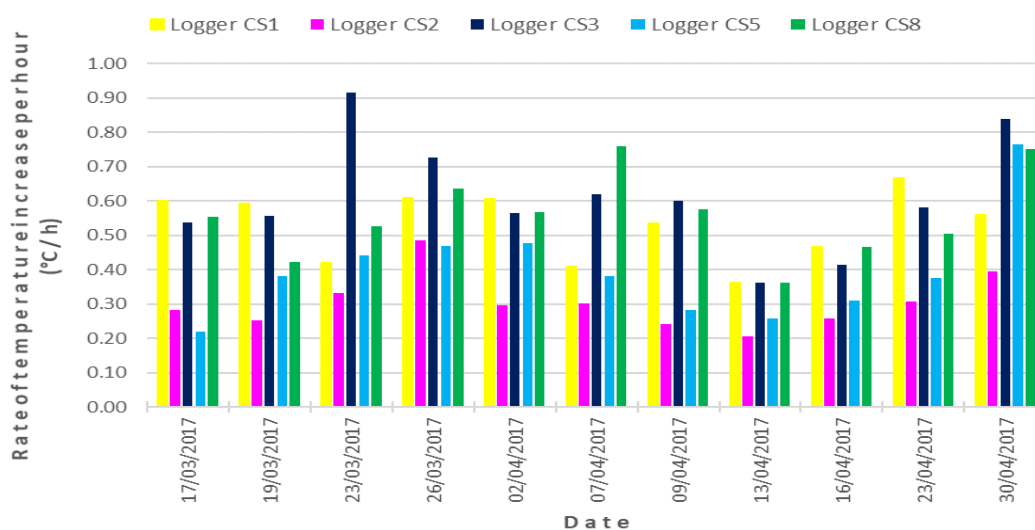

Figure 5.85 Killaloe cathedral rate per hour increase

The consolidated RH readings for Killaloe are shown in Figure 5.86 and the internal readings closely follow the external ones as a result of the heating only being on for one service on Sundays but the building being open every day.

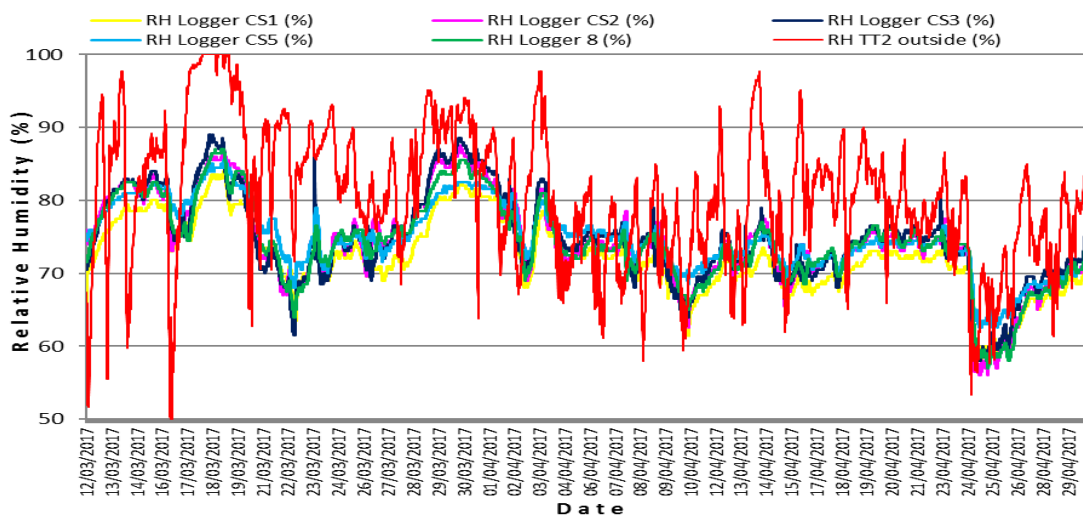

Figure 5.86 - Consolidated RH readings for Killaloe CI cathedral

The T readings for Raphoe are shown in Figure 5.87 and the boiler is capable of raising the ambient T to over 20°C on Sundays which is more than adequate for thermal comfort. Some heat is wasted in the cool down period, but it is not substantial. During the week the building is cold with an ambient T of around 12°C.

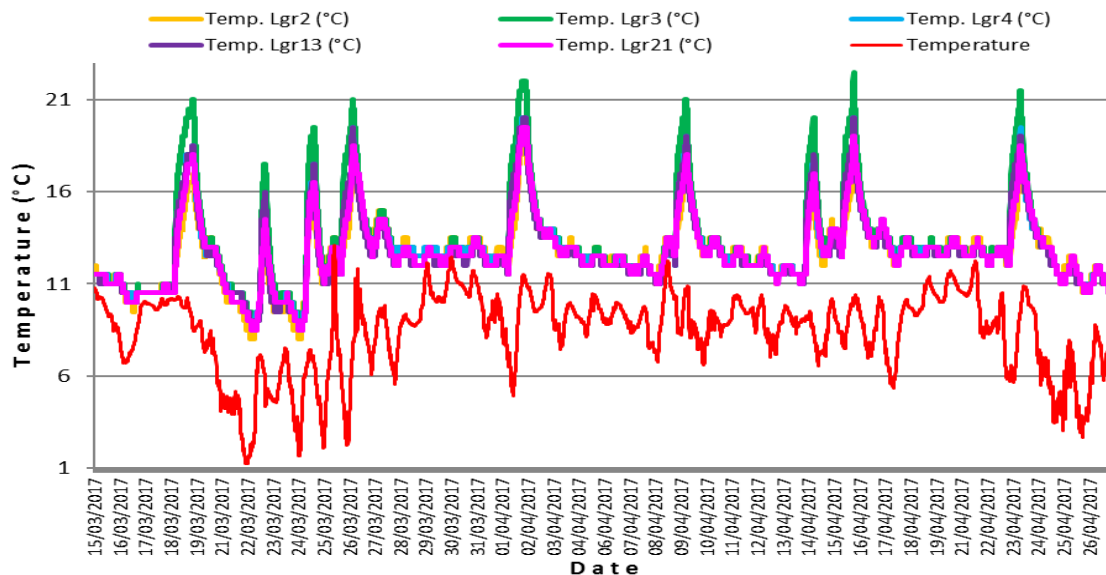

Figure 5.87 - T readings in St. Lasarian's Cathedral, Raphoe

It is clear when the heating is switched on for services, that it is on for long enough to heat the fabric of the building which results in some wasted heat evidenced by slow cooling rates for residual heat. The consolidated RH readings for Raphoe are given in Figure 5.88. If compared to Figure 5.86 (Killaloe), it is possible to observe that both interior and exterior trends follow each other quite closely as a result of both buildings having permeable building envelopes.

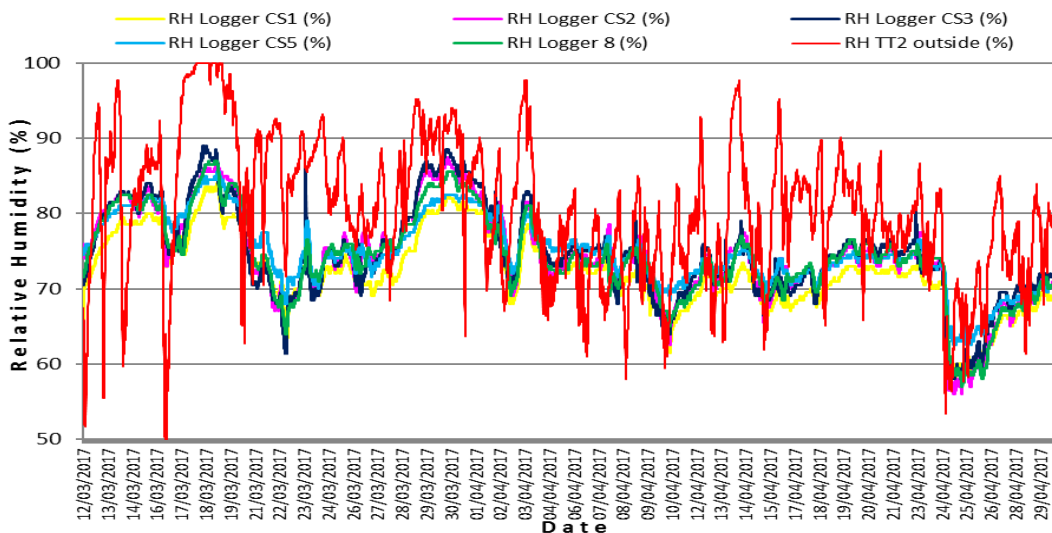

Figure 5.88 - Consolidated RH readings for Raphoe CI cathedral

The rate per hour increase for Raphoe is shown in Figure 5.89 and the floor plan with the detailed location of the loggers and TinyTag for this cathedral can be found in Appendix 18.

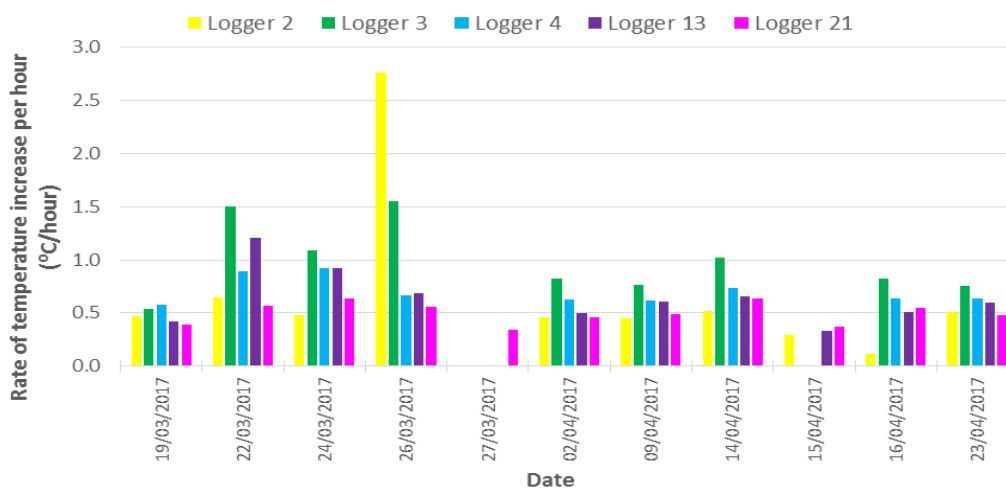

Figure 5.89 - Rate of temperature increase per hour in Raphoe's Cathedral

There is an even spread of heat increase throughout the building with an average rate/hr increase of about 0.5°C somewhat higher than Killaloe, presumably due to the better efficiency of the system and possibly lower losses. Overall ambient T readings were around 12°C in both cathedrals which is higher than normal, but the outside T had started to warm up by March (typically 8 - 10°C) and so the figures are not unusual. RH figures in both cathedrals were fairly similar at between 70 and 80% in each case which is quite high and is partly as a result of the low T figures as a result of the buildings having no artificial heat during the week. The high internal RH readings reflect the high external RH readings and internal condensation may not be unusual.

St. Lasarian's cathedral, Old Leighlin

This cathedral recently underwent a €500K refurbishment and as part of that the Lady Chapel was reroofed and reopened as a space where liturgical and civic events can take place. In order to heat

this new space, the cathedral installed an air source heat pump in the belfry, which dates from the 1520s, and installed pipes to carry warm water into the wall between the Lady Chapel and the nave. The heat pump is partly supplied with electricity from photovoltaic panels installed on the roof of the newly built toilets. They will shortly be installing radiant electric heaters built into the lights in the Lady Chapel in order to augment this novel heating system. The nave is heated with a domestic oil boiler feeding into an LPHW system. All of this work was done with the approval of the conservation and archaeology departments in the local council and all of the funds required were raised from grants. The cathedral has a potential congregation of some 100 people and raising such funds internally was not possible.

Temperature

The consolidated readings for temperature from the loggers are shown in Figure 5.90.

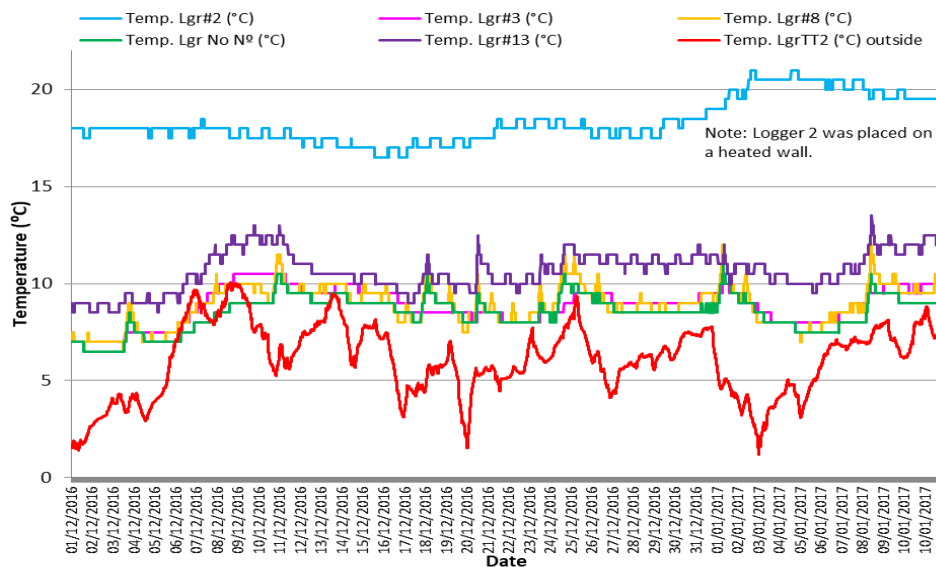

Figure 5.90 - Consolidated T readings from the loggers in Old Leighlin cathedral

The floor plan scheme with the location of the loggers can be observed in Figure 5.91.

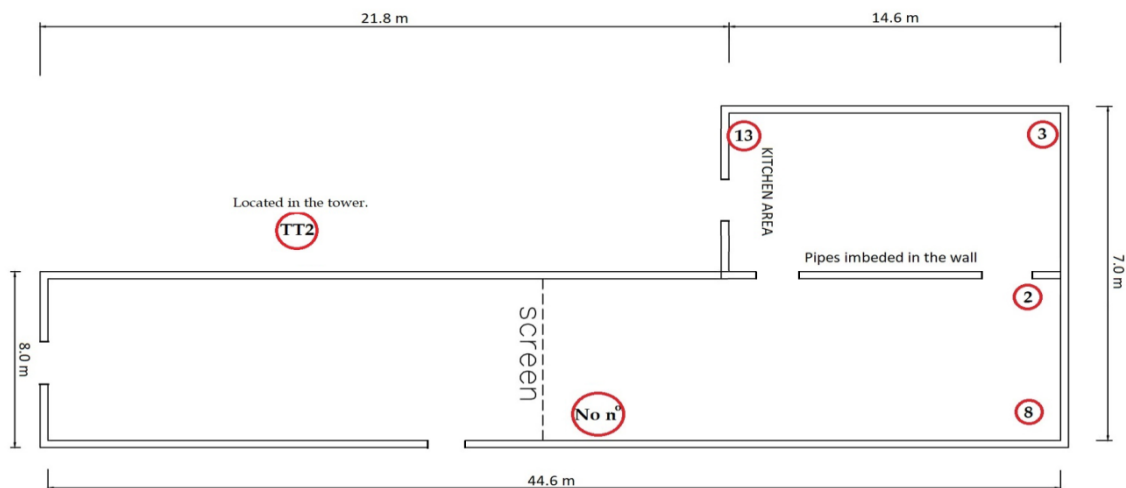

Figure 5.91 - Floor Plan Old Leighlin Cathedral

Logger 2 was placed on the nave side of the internal wall between the nave and the Lady Chapel, which is the wall containing the warm water pipes and this explains its high readings and suggests that it is always on. Logger 13 was placed near the kitchen area in the Lady chapel which may explain the slightly higher readings from that logger although it is unclear why any heat should radiate from the cathedral when the kitchen is not in use unless it was receiving heat from the heated wall. Apart from Logger 2 this cathedral displays many of the elements of an intermittently used LPHW system although the domestic sized boiler is perhaps not able to raise the T within the nave to comfortable levels in December, or it may be because it is not on for long enough to allow it to reach a higher T. If this internal ambient T of circa 10°C is common throughout the winter, then it is questionable if they should not in fact have upgraded the boiler during the major renovations. The thermal mass of the building enables the building to maintain an ambient T of circa 7°C even when the outside T is approaching zero. The inside wall of the Lady Chapel is plastered where the integrated pipes are situated but are solid stone on the nave side. Whilst the heat from this wall is helping to maintain a higher internal T than outside it is not possible, with the equipment available, to calculate the contribution which this novel heating system is having on the building. Further research could be justified to establish how significant the effect is. An ambient T of less than 10°C would be uncomfortable for the congregation and the LPHW system employed in the nave is not achieving a reasonable level of thermal comfort. This internal environment of low T and high RH will, over time, be damaging to both the building and its contents. This is the only active cathedral in Ireland with such a novel heating system. It has made the Lady Chapel usable although it will require extra heating, probably from the radiant electric heaters to be installed in the lights, to make it comfortable. The heating in the nave is not adequate but this problem might be solved by installing a larger boiler or by running the existing boiler for longer, should finances allow. It must be questionable as to why such a large sum of money was spent upgrading and renovating a building when the resulting heating system appears to be inadequate and is not providing an adequate level of thermal comfort even for the one service which is held each week. Further research is required to examine the issues here before such a novel heating system could be recommended for installation by other cathedrals.

Moisture

Consolidated RH readings for this cathedral are shown in Figure 5.92. It is notable that there is quite a disparity between the RH values in Old Loughlin cathedral. The RH readings are generally high (80-90%) and at a level which would promote mould (Bordass and Bemrose, 1998). There is a pipe organ in this cathedral and it would be adversely affected by these high RH readings. The TinyTag was situated in the belfry which was a suitable location and it shows that there was rain on quite a few days in December 2016. The internal RH figures follow the external figures and the various loggers

generally follow each other (but over a range of 10% RH throughout) as a result of the low ambient T readings and resultant high RH readings. Logger 13, which was situated at the kitchen end of the Lady Chapel, shows slightly lower RH readings than the other loggers because the T for this logger was higher. The high RH and low T readings suggest that the heating system as a whole is not providing either adequate levels of thermal comfort or adequate protection to the contents of the building. The heating system may be novel but it is not performing satisfactorily.

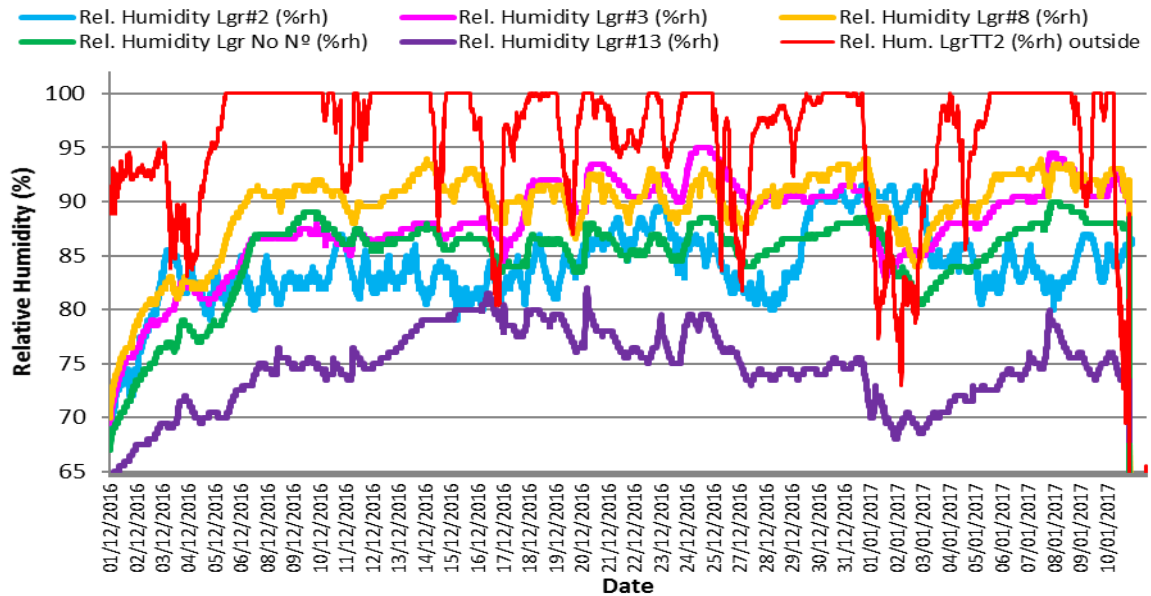

Figure 5.92 - Consolidated RH readings in St. Lasarian's Cathedral, Old Leighlin

St. Carthage's cathedral, Lismore

This is another small Church of Ireland cathedral which has an unusual heating system in that it relies entirely on electric radiant heaters to provide a level of thermal comfort, as shown in Figure 5.93, similar to St. Anne's in Belfast.



Figure 5.93 - The electric radiant heaters in Lismore Cathedral

Although the cathedral stays open on a daily basis for visitors, there is no monetary charge for entrance, so no record of visitor numbers is kept. It is another traditional cathedral, which has been altered many times over the centuries. One of the building features is its large flagged stone floor, which can be seen in Figure 5.76.

The locations of the loggers can be found in Appendix 20. St. Carthage's had 5 loggers installed inside and one logger (TinyTag) was placed outdoors, in order to also monitor the external T. One logger was placed in the library which is adjacent to the nave. This library contains many ancient books and is open to the public by appointment, as it can be seen on Figure 5.94 below.

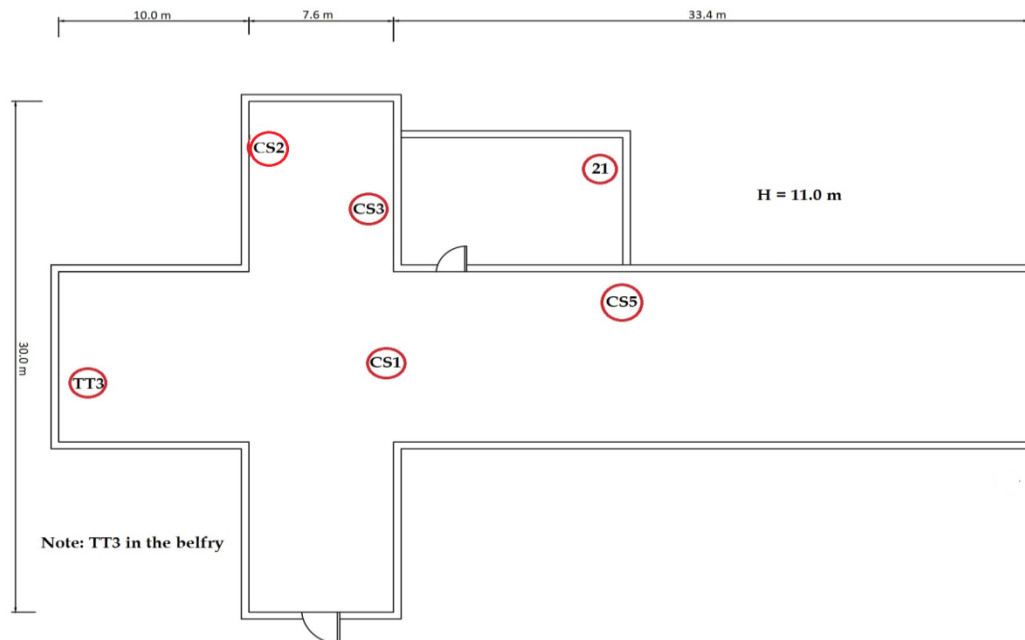

Figure 5.94 - St. Carthage's cathedral Lismore, floor plan.

According to the Dean of the cathedral, half of the building is not used for worship as a result of low attended services, and is therefore, not heated. Figure 5.95 shows the unused part of the cathedral.



Figure 5.95 – Lismore cathedral showing stone floor and area of the nave usually not used

The part of Lismore cathedral which is not used for regular services is separated from the area which is used by a glass and wooden screen which has been erected to contain some heat in both the choir area of the nave and in a side chapel and these are shown in Figure 5.96 with one half height screen being straight ahead and a screen to the nave to the right.



Figure 5.96 - The two screens in Lismore cathedral

These screens do not reach up to the roof and must be of limited value. The screen between the two parts of the nave (on the right-hand side in Figure 5.96) does have a curtain, which does cover the area between the screen and the roof but this was open at the time of the visits. Other cathedrals which have adopted this policy of not using part of the building, as a result of shrinking congregations, are Killaloe and Cloyne.

Temperature

The consolidated T readings are shown in Figure 5.97.

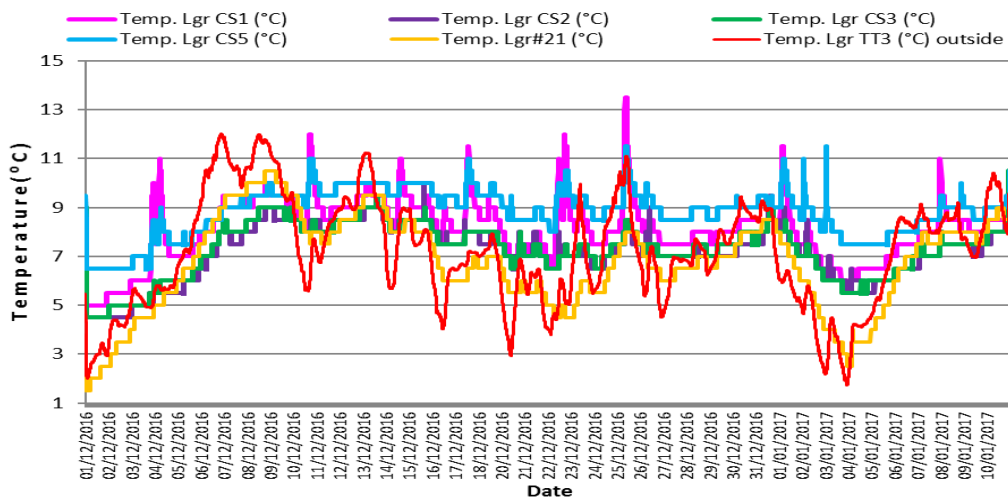

Figure 5.97 - Consolidated T readings in St. Cathage's cathedral, Lismore

It is possible to observe that the inside T closely follows the outside T. The TinyTag was in the belfry where it was exposed to the weather without being exposed to direct sunlight or rain. An internal ambient T of between 7 and 9°C is very low and, as in Old Leighlin, would not provide an adequate level of thermal comfort to those who are not in line with the radiant heaters. The times when the heaters are on can be identified but in general the average ambient T is 9°C as it is the people being heated not the air.

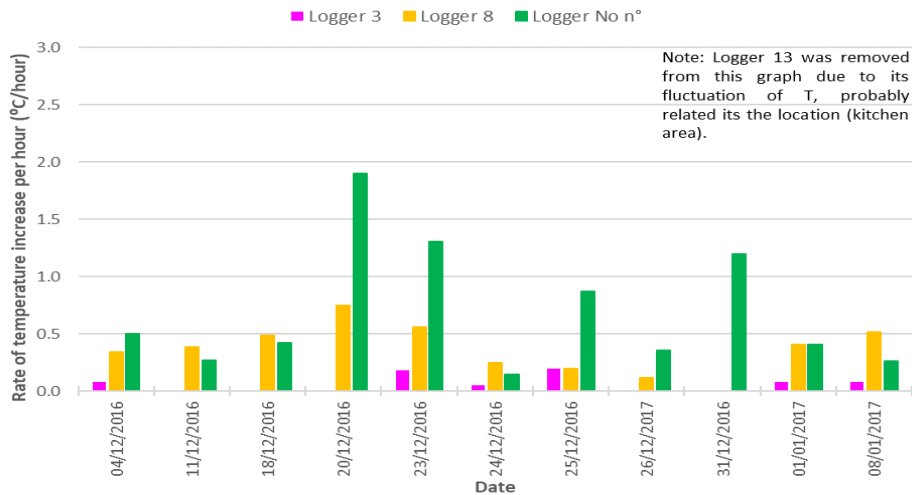

Figure 5.98 - Rate of T increase per hour for the loggers installed in Old Leighlin Cathedral

Figure 5.99 Illustrates the rate of T increase per hour in St. Carthage’s cathedral, Lismore.

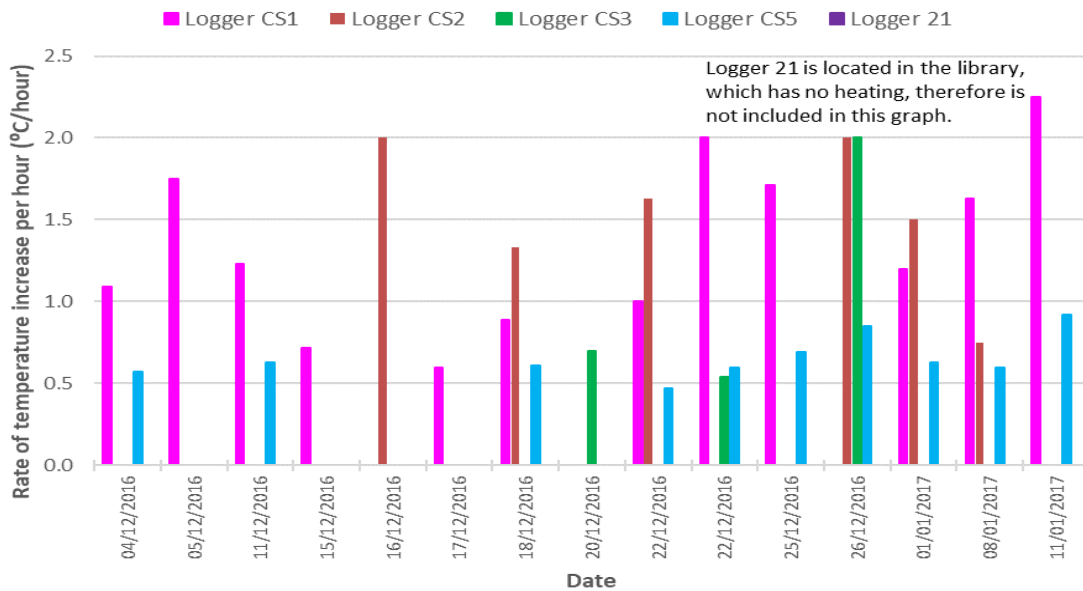

Figure 5.99 - Rate of T increase per hour in Lismore cathedral

Logger CS1 was placed on top of the screen which separates the nave and was at a height of 4 metres which may explain the higher rate of increase. The heating is not well spread throughout the building and there may be an element of solar gain as well as heat from the radiant heaters.

The T readings are not as stable as those in St. Anne’s in Belfast which was described earlier and which also relies solely on electric radiant heaters because the double doors in the North transept in Lismore are left open all day and every day throughout the year, in order to attract visitors to the cathedral, as can be seen in Figure 5.100.



Figure 5.100 - The North transept doors in Lismore cathedral which are open every day

Moisture

The consolidated moisture readings are shown in Figure 5.101. The figures show a situation which is both damaging to the building and its contents as a result of the high RH readings.

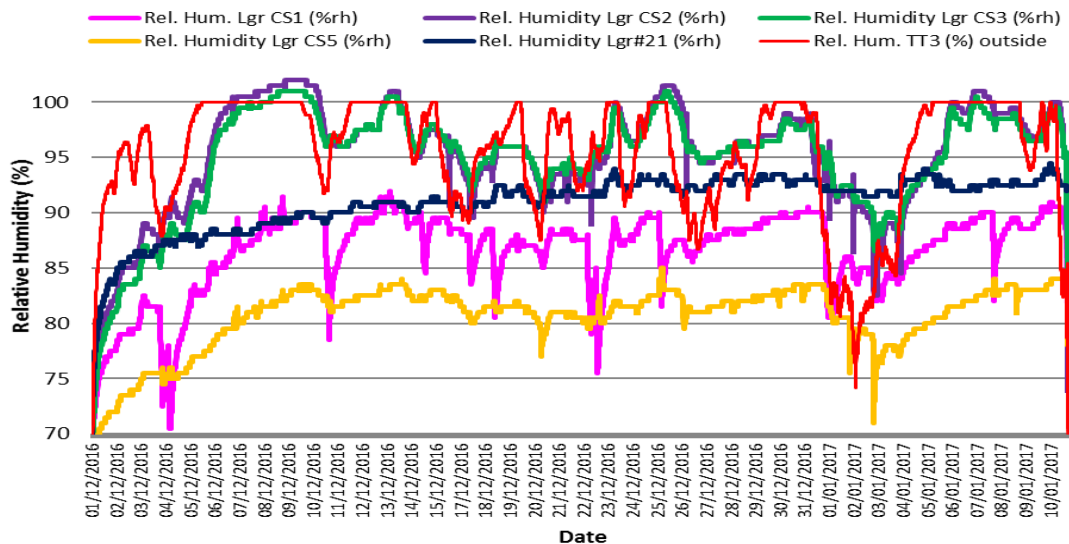

Figure 5.101 - Consolidated RH readings for St. Cathage's cathedral, Lismore

At times the internal RH readings exceed the external ones or at least equal them. On one site visit the internal floor temperature was measured as being -2°C which produced ice on the stone flags. It is the policy of the cathedral to keep the doors open all day and every day which in the summer should not be an issue, but the observations would suggest that this policy should be reviewed in the winter. The doors in St. Anne's cathedral in Belfast, where the building is open all and every day are not left open which allows a reasonable internal ambient T and RH to be maintained. RH levels which are constantly at or near 90%, cannot be conducive to the proper care of the books in the library, which in Lismore is situated off the nave. As Camuffo (2014) quotes in relation to books, 'if RH is halved, life expectancy is doubled' (Michalski, 2000; Canadian Council of Archives, 2003).

The radiant heaters may provide sufficient levels of comfort to those sitting in line with the heaters, but these very high RH readings and very low T readings are likely to make the internal environment

generally uncomfortable for even a short period of time. It may be that this issue could be solved by opening a smaller door leading into a new vestibule, like many RC cathedrals, and keeping the large North transept doors closed, at least during the winter.

St. Macartan's cathedral, Enniskillen

Another of the small cathedrals which will be examined individually will be the Church of Ireland cathedral in Enniskillen. This is included because it has a unique heating solution, that being an oil fired boiler supplying a hot air blower. Unlike St. Mary's cathedral in Cork, which is the only other cathedral in Ireland with a hot or warm air system of heating, (Derry CI cathedral has hot air and LPHW), the inlet and outlet grills in Enniskillen are set in the floor of the nave at the East end of the cathedral, as shown in Figure 5.102. St. Mary's cathedral in Cork also has small electric radiant heaters, the effects of which are not known.



Figure 5.102 - Inlet and outlet grills for the hot air heating system in Enniskillen cathedral

The layout of this cathedral is quite complex as there is a balcony running around half of the nave and this will create complex air movement patterns within the building. This balcony can be seen in Figure 5.103. It can also be noted that the cathedral contains a number of flags which will be susceptible to changes in both T and RH.



Figure 5.103 - Enniskillen cathedral showing the balcony and flags

The placing of the loggers in this building was difficult because of the balcony and the locations can be seen in Appendix 12. Loggers CS1, CS2 and CS5 were placed beneath the balcony and CS4 and CS3 were placed in areas not covered by the balcony. The TinyTag was placed in a suitable position in the cathedral belfry. There are extensive areas of wood within the building but these are relatively old and have most likely adapted to the current method of heating without further deformation.

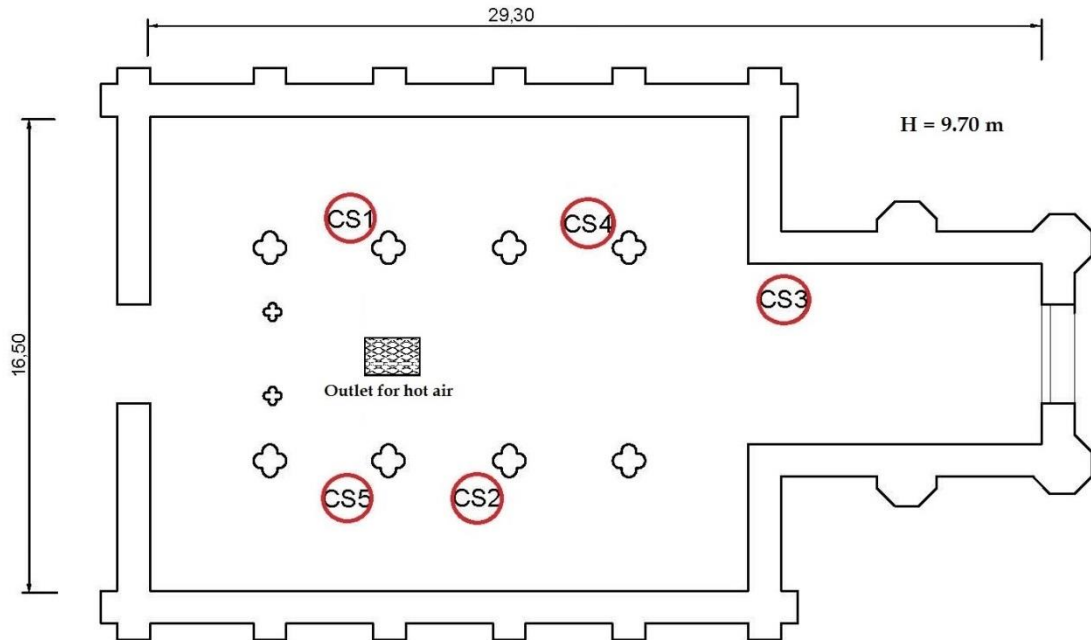

Figure 5.104 - Floor plan Enniskillen

Temperature

The consolidated readings for T for this cathedral are shown in Figure 5.105.

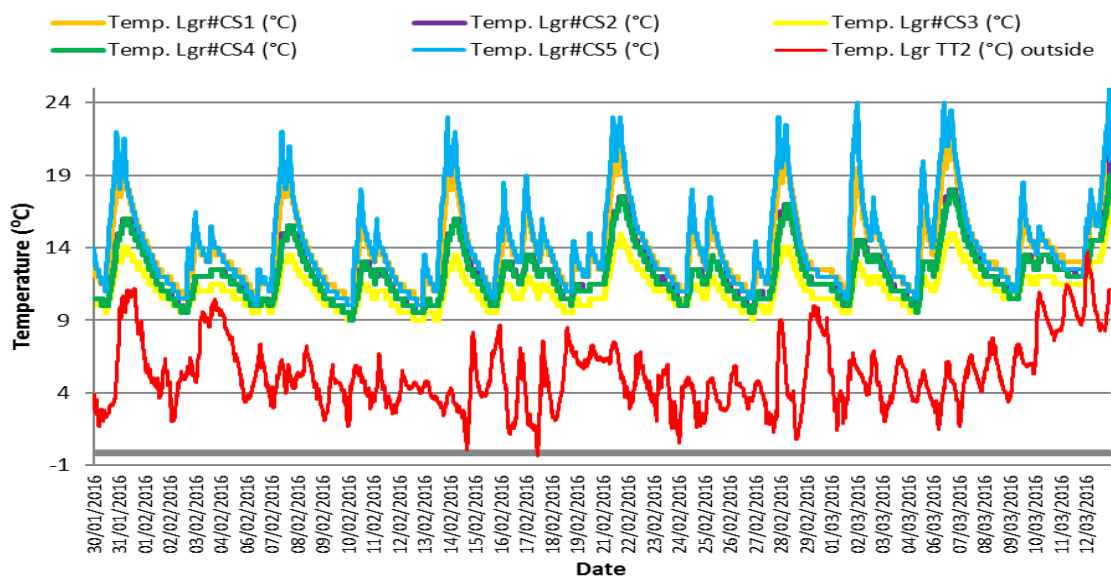

Figure 5.105 - T inside and outside for St. Macartan's Cathedral, Enniskillen

The rapid rise in T is typical of buildings employing hot air heating systems and should be compared with Figure 5.57 in reference to St. Mary's in Cork. The slightly slower rate of cooling is wasting heat

however, because the heating is on for long enough to heat up the fabric of the building and the fall from 14°C to circa 9°C can take over two days. An internal ambient of circa 19°C would provide more than adequate levels of thermal comfort for the Sunday service especially when external T hovers around 4°C. Figure 5.106 shows the effect of this slow cooling over a ten day period from 7 to 17 February 2016.

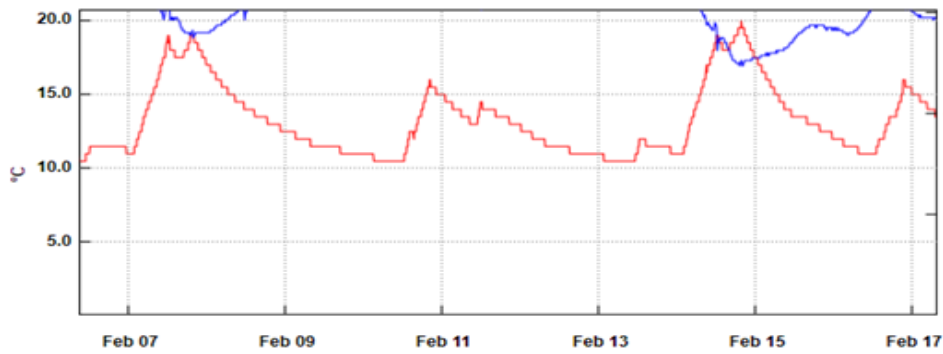

Figure 5.106 - Logger CS1 in Enniskillen. From Feb. 6th to 17th 2016

It can be observed that the internal readings do follow the external readings to some extent (there is no strong overall trend externally) but what is particularly noticeable is the fast warm up times followed by slower cooling down times and the very clear indication of the heat coming on and off. It can be observed by considering just Logger CS1 from 7 February 2016 until 17 February 2016 (Figure 5.106) that the rate of increase is fast and the rate of cooling much slower. This is because the building is heating up and the thermal mass is allowing the heat to be released over a long period. This slow rate of heat release is actually wasted heat because the cathedral is empty during this period. Calculations for different dates and different rates of increase and decrease can be found in Table 5.5. St. Mary's in Cork, which also has a hot air system although the air comes in at a different height and place in the cathedral, cools down much more quickly.

Table 5.5 - Enniskillen cathedral with details of the time taken for T to fall or rise

DATE	TIME	T °C	ΔT °C	TIME TO RISE	TIME TO FALL
7.2.16	00:46	11.0	-	-	-
7.2.16	19:48	19.0	8.0°C	19hrs	-
10.2.16	06:16	10.5	-8.5°C	-	59h 23min
10.2.16	11:42	10.5	0°C	-	-
10.2.16	20:19	16.0	6°.0C	8hrs 37mins	-
14.2.16	00:27	11.0	-5.0°C	-	76hrs 8mins
14.2.16	19:56	19.5	8.5°C	19hrs 20mins.	-
16.2.16	09:33	11°C	-8.5°C	-	37h 37min

The rates of increase of the T registered in the various loggers in Enniskillen are shown in Figure 5.107.

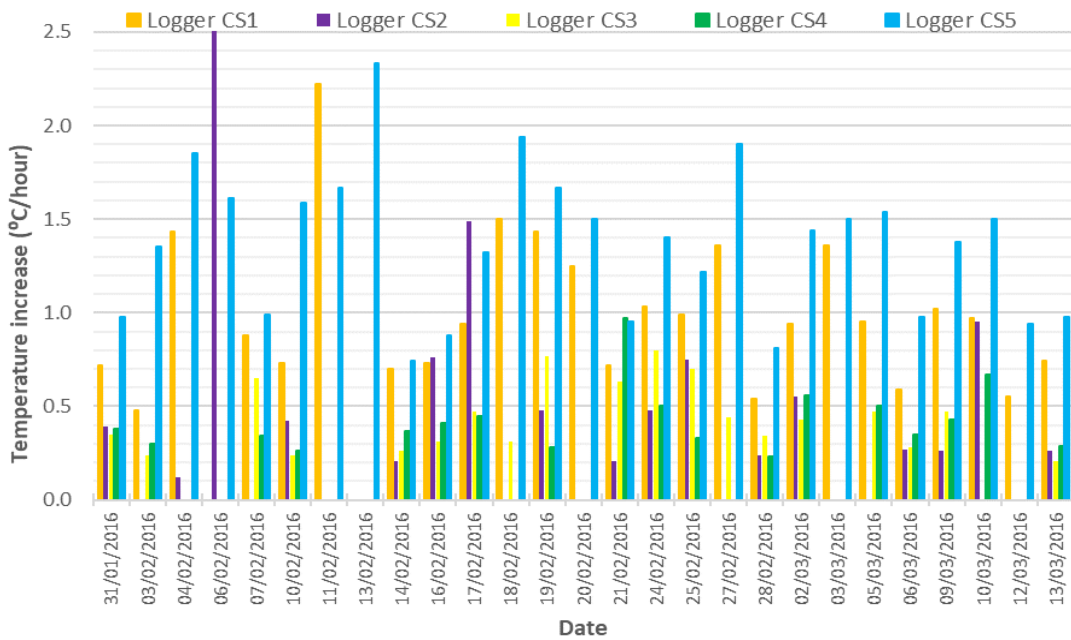

Figure 5.107 - Rate of increase in T per hour for the inside loggers in Enniskillen

It is possible to observe that the rate is small (typically between 0.5 and 1.0°C/hr) when compared with St. Mary's in Cork. The solution might be for Enniskillen cathedral to install a more modern boiler to produce more warm air over a shorter period so that the building does not heat up. The age of the existing boiler, which is shown in Figure 5.108 was not known.



Figure 5.108 - Oil fired boiler in Enniskillen cathedral

The widely differing rates of increase are explained by the fact that some of the loggers were placed near to the warm air outlet grill and beneath the balcony which is the area of the cathedral which would heat up first and most quickly as the warm air rises from the grill.

As has been mentioned this cathedral has some intrinsically valuable flags inside the building which are susceptible to changes in the internal environment and it also has a pipe organ which is also susceptible to such changes.

Moisture

The consolidated moisture readings for the various loggers are shown in Figure 5.109.

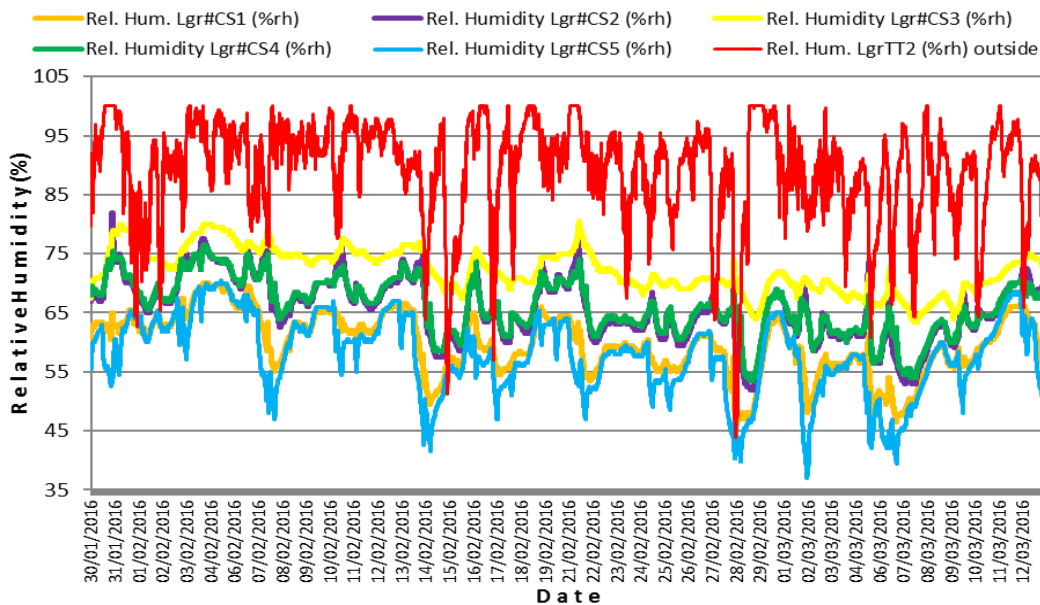

Figure 5.109 - Consolidated RH readings for St. Macartan's cathedral, Enniskillen

The internal RH readings follow quite closely the external readings but are considerably lower. These moisture readings are within a range which would not adversely affect the building or its contents and the largest changes are circa 20% which again is reasonable but the rises and falls are not as extreme as in St. Mary's in Cork perhaps because the boiler in Cork, for which details were not available, may be more modern. The location of the air outlet grill is substantially different in the two cathedrals. It has also to be determined what effect the small electric radiant heaters in St. Mary's have on the internal environment of that cathedral. Cork is a much larger cathedral and so for it to obtain the rate per hour increase which it does, implies a very powerful boiler is in place, which may have noise constraints. The heating system in Enniskillen was noticeable from a noise point of view but it was not obtrusive.

St. Brigid's CI cathedral, Kildare

This CI cathedral has had a long and troubled history but there are records of a church existing on the site in c. 630 (Galloway, 1992). The existing building, whilst it has elements from the 13th century, was largely rebuilt in the late 1800s by the architect George Edmund Street, who was also responsible for the major restoration work in Christ Church cathedral in Dublin. The locations of the loggers in the building are shown in Figure 5.110.

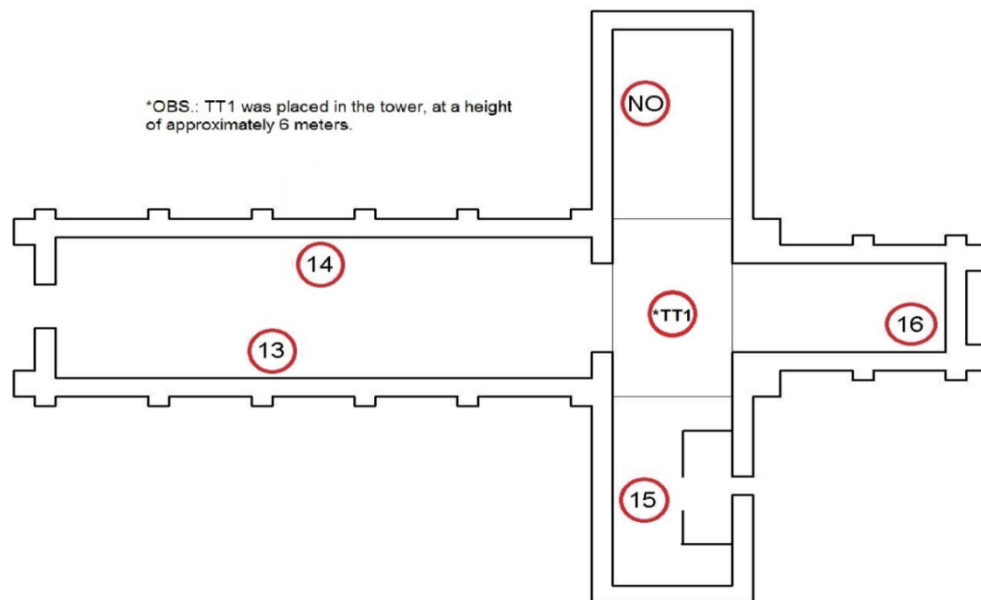

Figure 5.110 - Floor plan St Brigid's Cathedral, Kildare

The heating system is a gas fired LPHW system with a separate system for the organ which is kept in its own thermal environment separate from the rest of the cathedral. The gas boiler was replaced in 2006 but most of the pipe work was last replaced in 1914 and steps are in hand to raise the funds to replace the pipe work. Figure 5.111 gives an indication of the present state of the pipe work.



Figure 5.111 - Pipe work in St Brigid's cathedral, Kildare

The average congregation for the weekly Sunday service is between 15 and 20 people. The reason why this cathedral has been singled out for comment is because its heating profile is exactly what would be expected from an intermittently used LPHW system and where the heating is on for set period rather than to achieve a given T. However, with only one service a week for a small number of people the question must be asked if the present heating system and regime is suitable and whether it might not be better to consider a local heating system rather than upgrade the present system. It is the view of the researcher that a dual system whereby the main LPHW system is used when the cathedral is full but that either local heating such as electric panels on, under and in front of the pews, or electric radiant heaters be employed, for regular Sunday services.

Temperature

The consolidated T readings are shown in Figure 5.112.

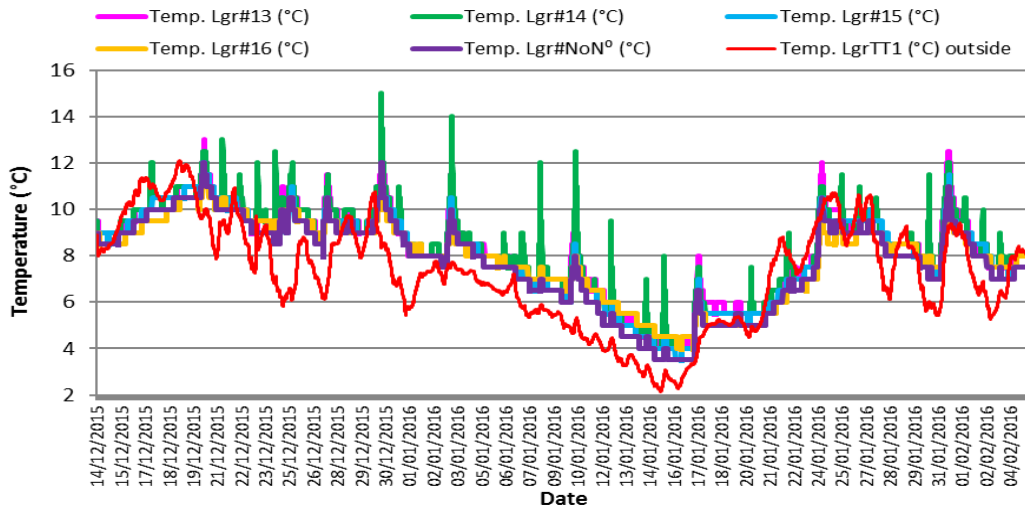

Figure 5.112 - St. Brigid's cathedral, Kildare, consolidated T readings from the loggers and TinyTag

The peaks on T shown in logger 14 were caused by sunlight striking the logger from the opposite side of the cathedral. The Tinytag was placed up in the belfry. It is notable to observe from the graph how closely the indoor T readings follow the outdoor T readings, especially between 3rd and 14th January, due to the heating being on for a short set period each Sunday and the fact that the building envelope is permeable. As the internal T follows the external T so closely, this results in a very low internal ambient temperature. For instance, on 17.1.2016 which was a Sunday, the ambient T did not rise above 5°C, which is unusual for an LPHW system that heats the whole of the indoor space. The rate of T increase per hour is shown in Figure 5.113 and with the exception of logger 14, which was explained in a previous paragraph, the rate is very slow. This might indicate that the boiler was not of sufficient output to heat the space required or that it needs to remain on for longer in order to arrive at a comfortable ambient T, which it clearly does not do at the moment. Irrespective of the low numbers attending, a temperature this low is not suitable for church services.

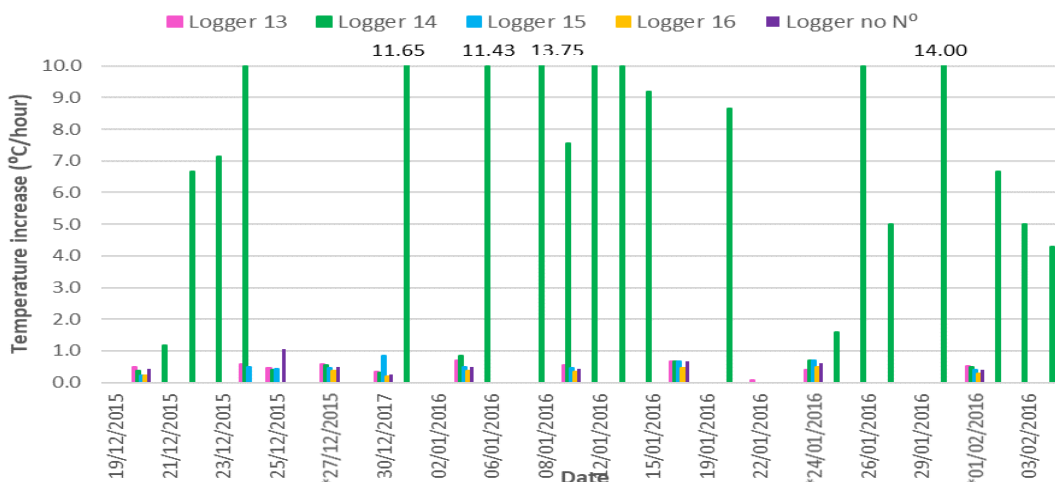

Figure 5.113 - Rate of temperature increase per hour for each logger in St. Brigid's cathedral, Kildare

It must be asked why this cathedral does not consider, if funds allow, installing a separate heating system such as radiant heaters, for some of the pews and keep the LPHW system for the few large annual services which are held each year, such as at Christmas and Easter. The present system is inadequate and, as the RH readings show (Figure 5.114), it is likely to be damaging the building and its contents.

Moisture

The consolidated RH readings are shown in Figure 5.114.

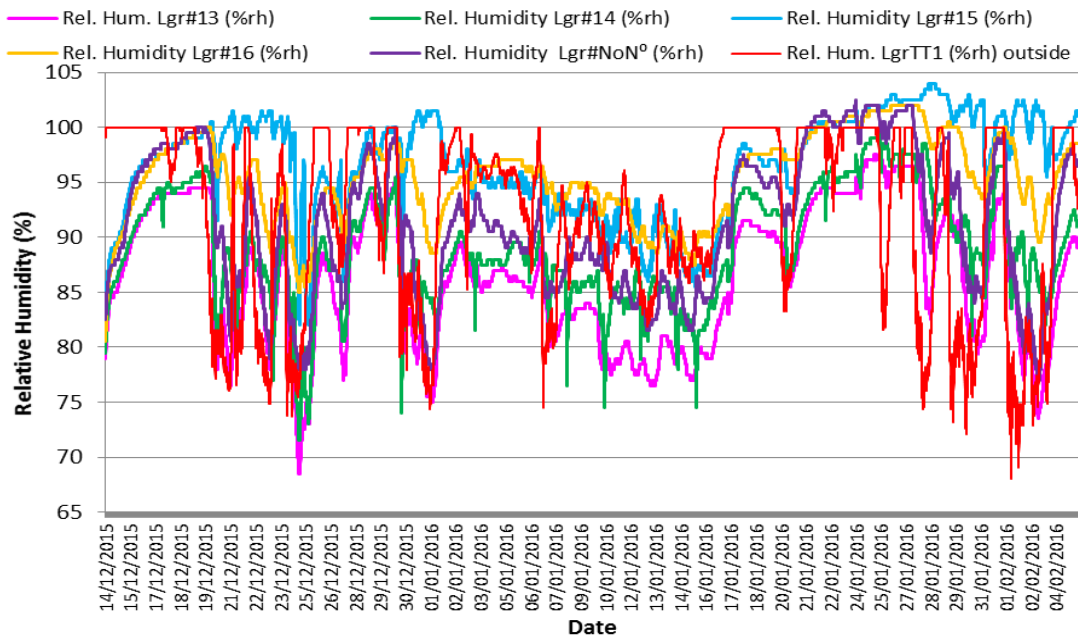

Figure 5.114 - Consolidated RH readings for St. Brigid's cathedral, Kildare

It can be observed that the ambient RH is high at around 90% which is a direct reflection of the low T readings and the fact that the building allows a large ingress and egress of air. The internal RH figures, like the T figures, follow closely the outside figures. These high RH figures will not only make the internal thermal environment uncomfortable but will damage the building and its contents. It is known that the heating system itself has leaks in the building which will only increase the internal RH figures.

5.4.3 Monitored small RC cathedrals

The RC cathedrals which were monitored, namely Carlow, Skibbereen and Loughrea, are all busy country town cathedrals which hold services every day and hence are open every day. Tourist visitors to these cathedrals would be small in number. These small RC cathedrals show many of the characteristics of all RC cathedrals which is not surprising since they all operate the same way. The size of the building is not the most important factor, except that the larger the size of the building the greater the volume to be heated, but it is the usage which makes the greatest difference to the internal environment.

Cathedral of the Assumption of the Blessed Virgin Mary, Carlow

The individual logger readings for these cathedrals are shown in Appendix 23 for Carlow, 25 for Skibbreen and 24 for Loughrea.

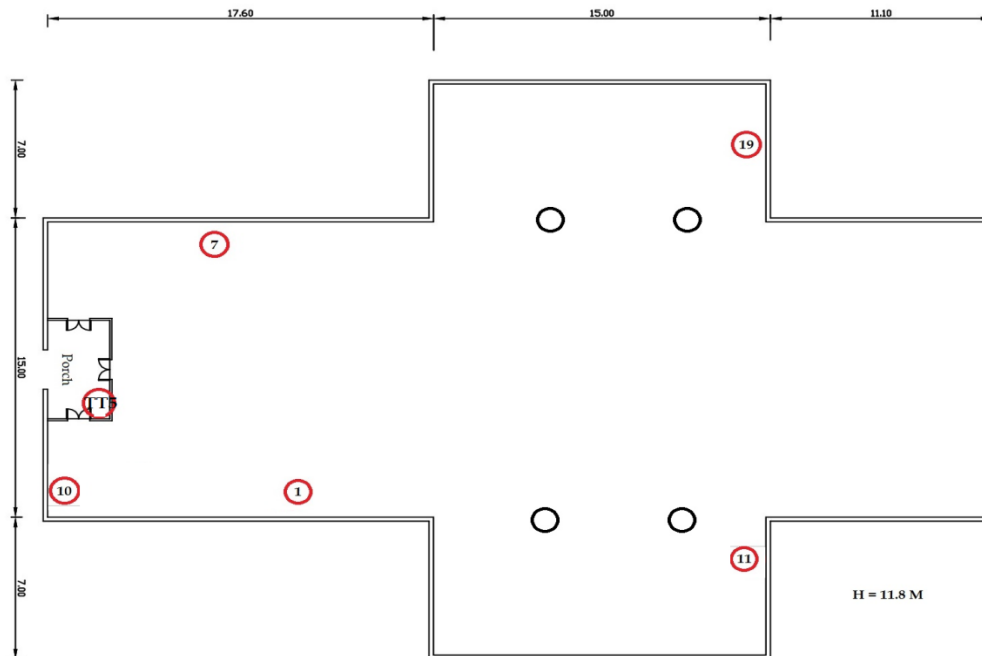

Figure 5.115 - Floor plan Cathedral of the Assumption of the Blessed Virgin Mary, Carlow

The internal T readings in Carlow are as seen in Figure 5.116 and the location of the loggers is shown in Appendix 23. In summary it is small, warm and frequently used.

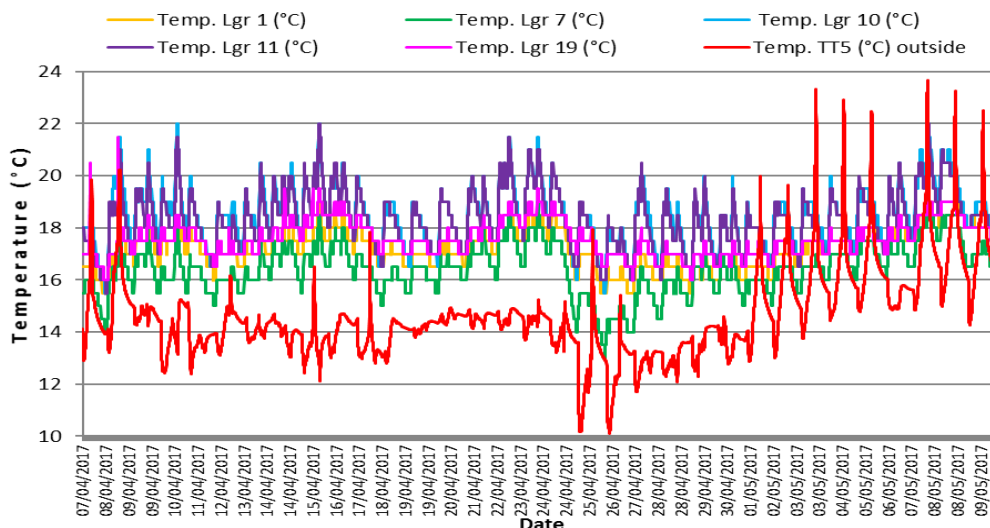

Figure 5.116 Carlow cathedral's consolidated T readings

These tended not to closely follow the external environment. The heat was still on during the period but because the ambient T had moved up because it was Spring (at circa 14°C), the heating only had to raise the T by circa 2 or 3° C each day to achieve an average ambient of circa 18°C. This tended to

distort the average rate of T per hour increase which for Calow was 1.0°C/hr and which varies as shown in Figure 5.117.

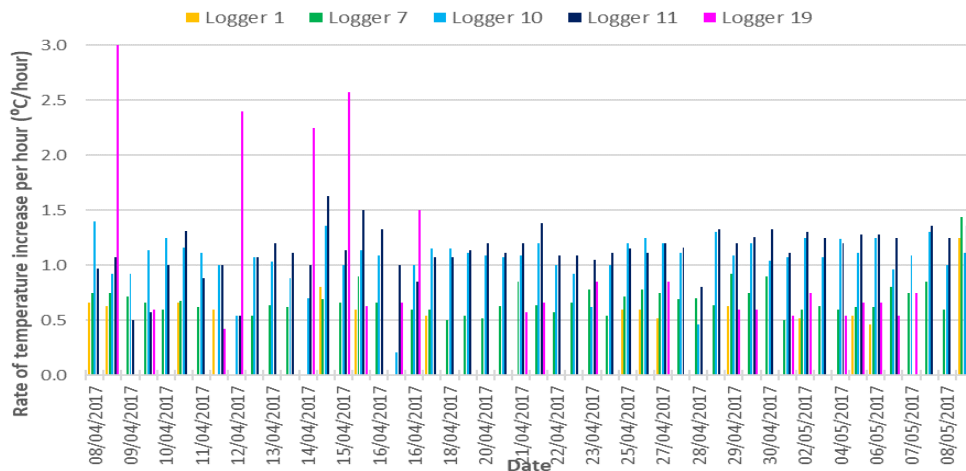

Figure 5.117 - Amalgamated T readings for Calow's cathedral

The individual loggers showed a very even spread of rate of increase (except for some outliers which can be ignored as being unrepresentative). This may imply a powerful boiler which can raise the internal T quickly and may also imply a low rate of exfiltration and infiltration, in a relatively small space.

St. Brendan's cathedral, Loughrea

In Loughrea the internal and external readings tended to follow each other and a gradual increase in the ambient T, as a result of the weather, can be noted and is shown in Figure 5.119. The daily heating cycle is clear and the boiler is obviously powerful enough to raise the ambient T quite fast. If the cathedral had a control to cut off the heat at 20°C energy could be saved since it is not necessary for thermal comfort reasons for T to be above this. The unusual saw tooth pattern shows that the building is quite slow to warm up and to slow down. The rate per hour increase is shown in Figure 5.119.

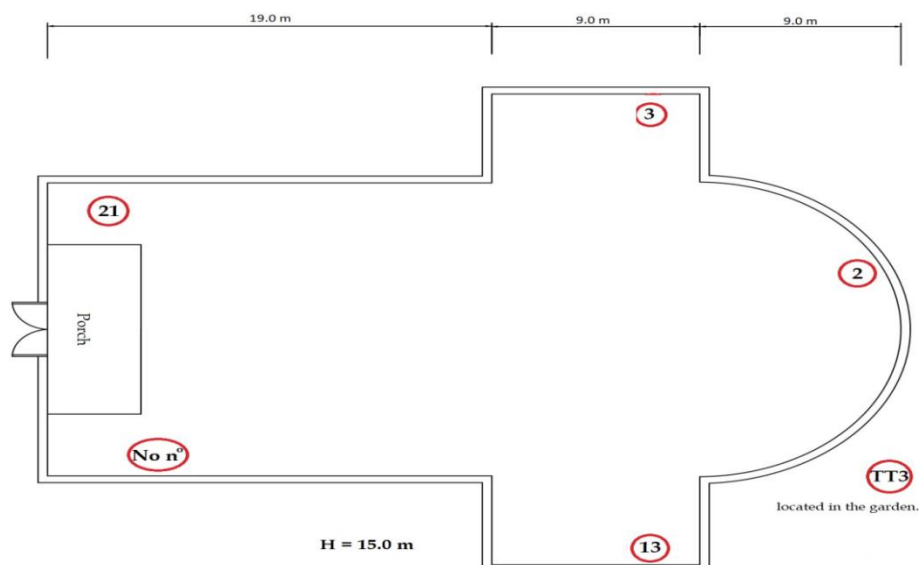

Figure 5.118 - Floor Plan St. Brendan's cathedral, Loughrea

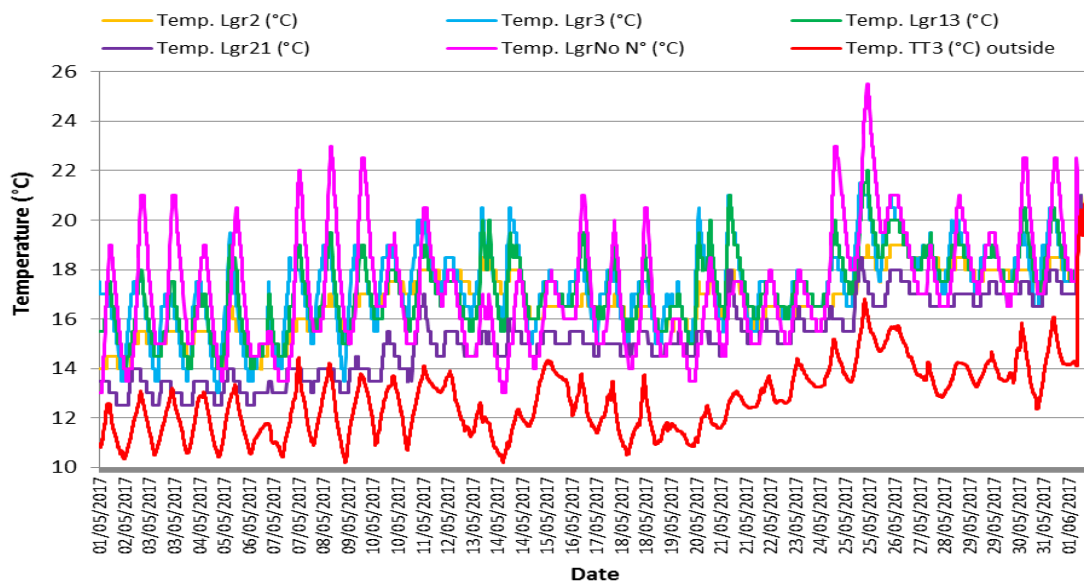

Figure 5.119 - Consolidated T readings for Loughrea cathedral

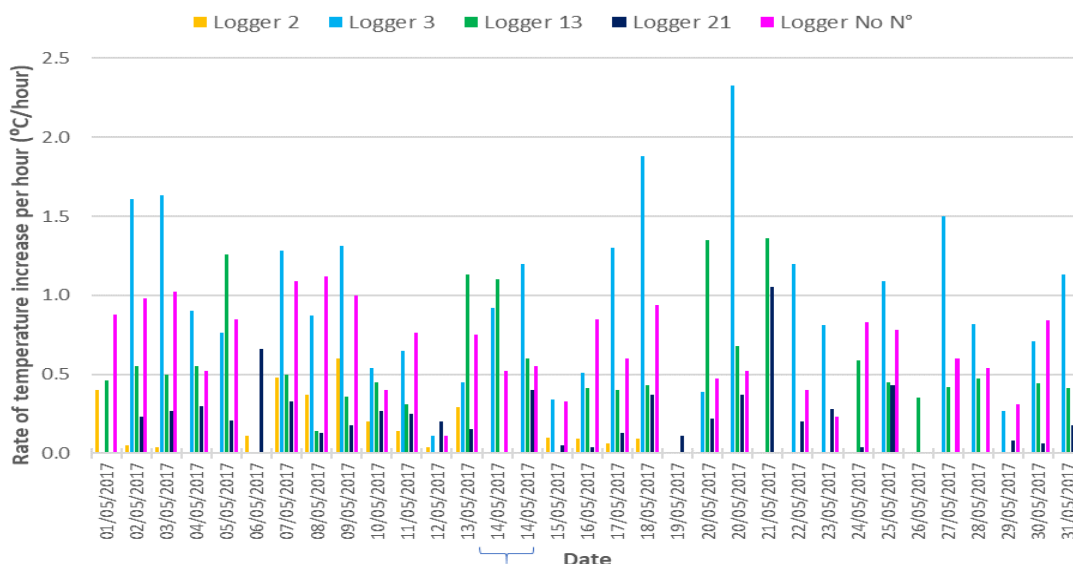

Figure 5.120 - Rate of T increase per hour of Loughrea Cathedral

Figure 5.120 shows a rather uneven spread of heat throughout the building which may be as a result of solar gain as the readings were taken in May. Towards the later part of the monitoring period some of the loggers are showing no increases as the internal and external environments mirror each other.

St. Patrick's Cathedral, Skibbereen

Skibbereen cathedral used the heating intermittently during the monitoring period and the figures from the loggers were very stable with an ambient T of between 16 to 18°C as shown in Figure 5.122 below. The pattern is quite different to that of Loughrea with smaller rises and falls and therefore a more stable internal environment. Skibbereen has a fast gain and slow release of heat which may imply a more powerful boiler than that fitted in Loughrea.

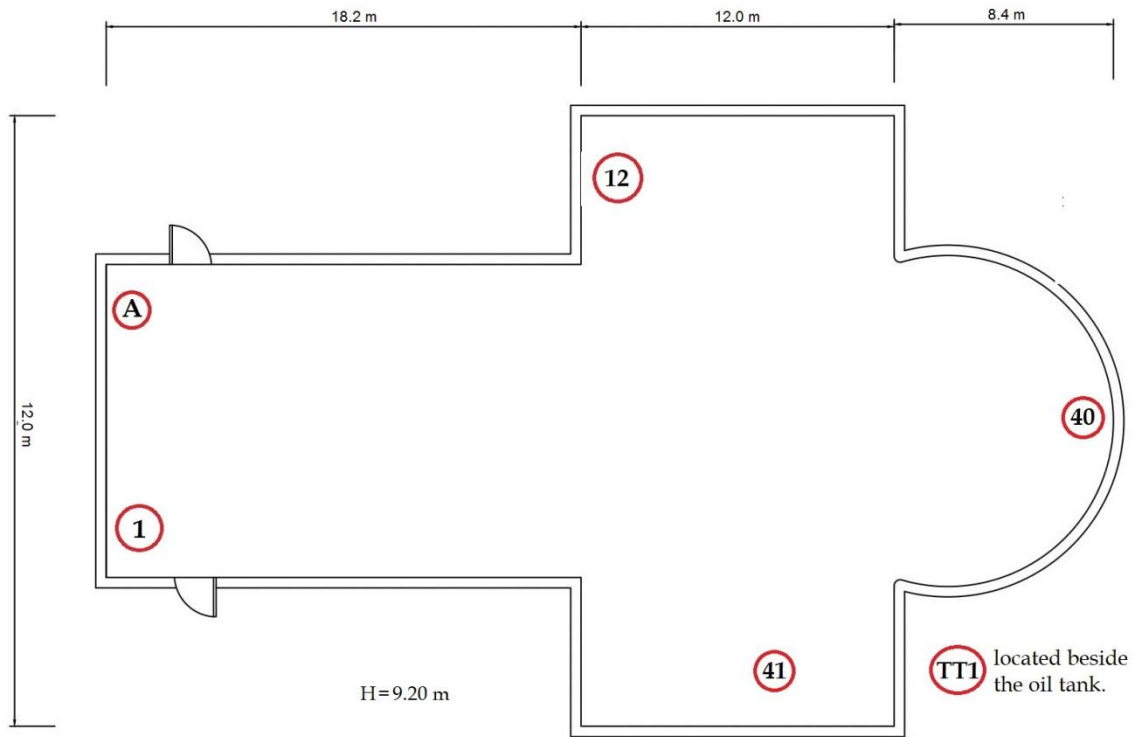

Figure 5.121 - St. Patrick's cathedral, Skibbreen

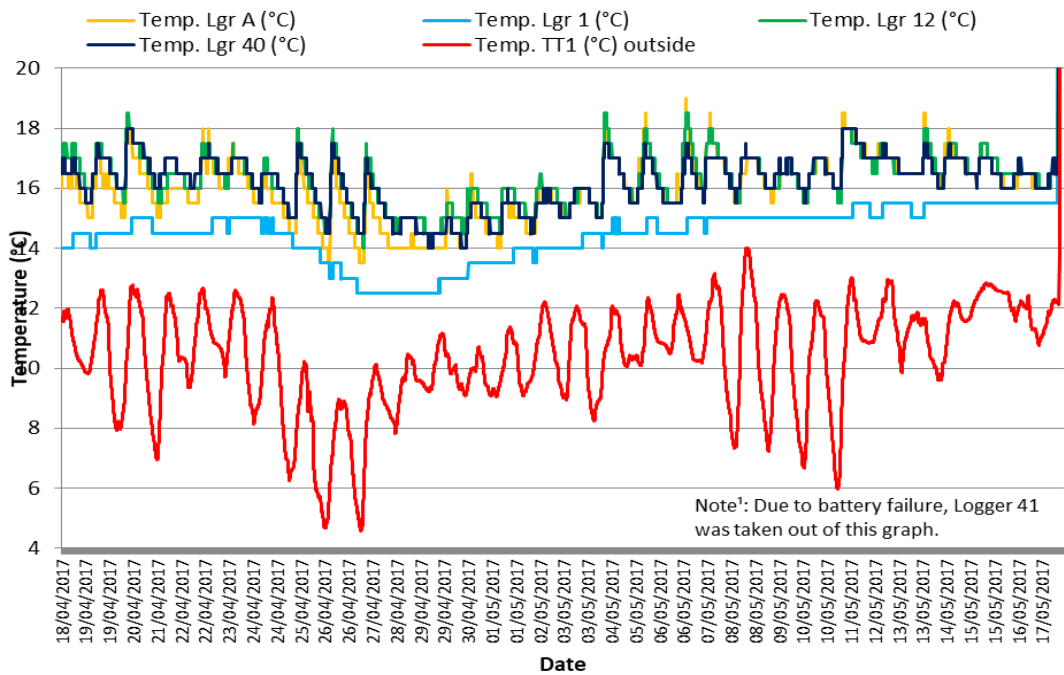

Figure 5.122 - T readings (indoors and outdoors) for St. Patrick's, Skibbreen

The rate per hour increase graph closely follows the consolidate T readings graph which implies a well-insulated building with little ingress and egress of air. This is because the thermal mass of the building was able to hold the T at a stable level at around 16°C. The outside T varied but was around 10°C during the monitoring period with a high of 14°C and a low of 5°C.

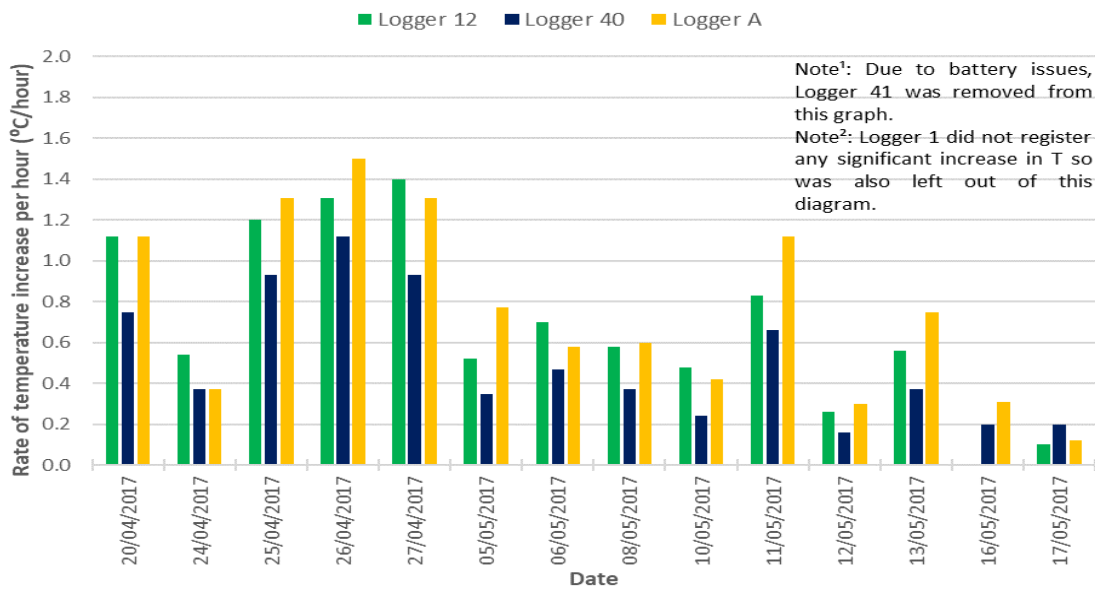

Figure 5.123 - Rate of T increase per hour in Skibbereen Cathedral

The difference between the inside and outside T readings would suggest that this cathedral is quite well sealed and that ingress and egress of air is less than in the other cathedrals, such as Raphoe, and this would tend to be supported by the RH readings for Skibbereen which are shown in Figure 5.124. Hence RH values are consistently 50-65% RH throughout adding credence to the stable nature of the internal environment.

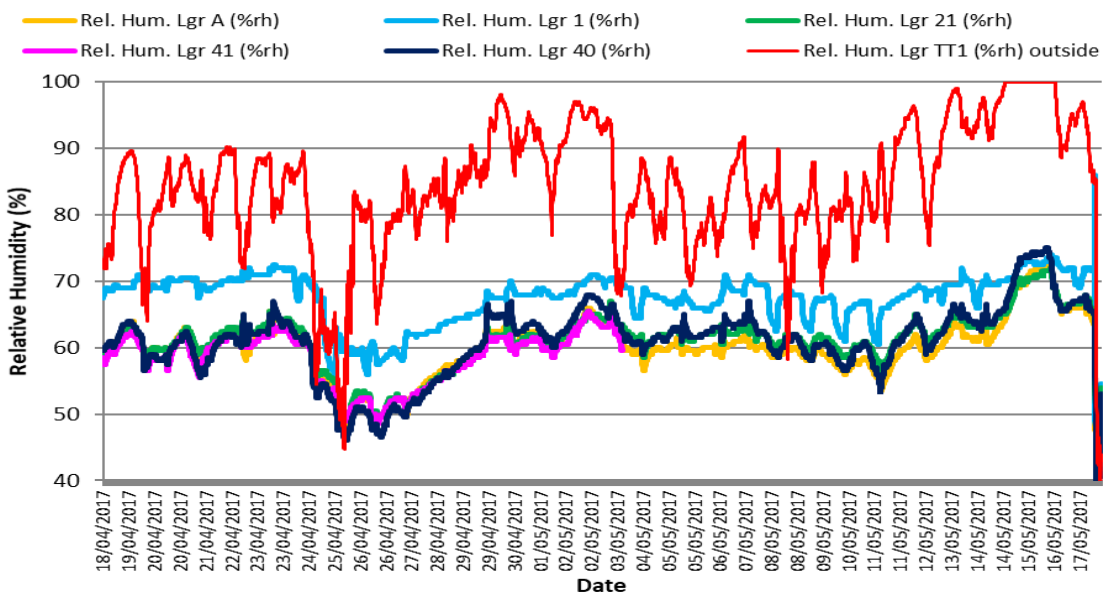

Figure 5.124 Amalgamated RH readings for Skibbereen Cathedral (indoors and outdoors)

5.4.4 Not monitored small cathedrals

The cathedrals which were not monitored numbered 15 with Tuam and Ennis being the only RC cathedrals in the group. As with the monitored RC cathedrals, these two are busy cathedrals situated in rural towns. They have services every day with both cathedrals holding eight services per week. The remaining 13 cathedrals which were not monitored all belong to the Church of Ireland and they

are spread throughout the island of Ireland. Kilfenora, for example, has a heating system unlike any other in a cathedral in Ireland, namely underfloor electric. The Grade 1 Conservation Architect who chose this system was interviewed and stated that he considered that this was the most suitable system for this particular cathedral given the very small number of services held in the building each year. The cathedral only holds three or four services a year and, in addition to the underfloor heating, it has two fireplaces which are also used during services. One of the fireplaces can be seen in Figure 5.125.



Figure 5.125 - Interior of Kilfenora cathedral showing box pews and one of the fireplaces

The building was being managed during the visit of the researcher by The Office of Public Works (OPW) which is a government body. This may have been to supply information to the many visitors who visit this part of Ireland each year as it is on the edge of an area called The Burren National Park. A photograph of this, the smallest cathedral in Ireland is shown in Figure 5.126.



Figure 5.126 - Kilfenora cathedral

5.4.5 Key findings for small cathedrals

The key findings for small cathedrals which supplement the findings from other size categories are:

- Size is not a major determinant for the internal thermal environment in small cathedrals. Usage and infiltration have a greater influence.
- In the case of small RC cathedrals, they are very similar to all other RC cathedrals in terms of use and opening hours. Understandably congregations are smaller in smaller cathedrals and the heating systems diverse, but many other things are similar despite the difference in size.

- CI small cathedrals tend to be cold, sparsely used and have a variety of heating systems of varying degrees of effectiveness.
- The change of use in CI cathedrals over the decades has not been mirrored by a change in heating systems or regimes.
- In CI cathedrals it is common for internal T and RH readings to more closely follow the external T and RH readings due to the porosity of the older buildings and the intermittent nature of the heating regimes employed.

5.5 Gradients for differing heating regimes and types found in Irish cathedrals

The results have demonstrated that the different heating regimes and heating types produce distinct and different heating profiles and it is felt important that the managers of the cathedrals understand these profiles in order to maximize the efficiency of their heating systems. The differing heating profiles have a direct influence on the internal thermal environment of the cathedrals as well as the amount of energy used to heat the buildings which in turn has a direct influence on the cost of heating the buildings.

Figure 5.127 is an example of a LPHW system which is on full time in the winter and the graph shows one typical logger.

This logger, which is replicated by other loggers, shows the stability of this type of heating with no more T change than 1°C. March 22, 2015 was a Sunday but this was immaterial to the conditions as the cathedral runs the heating continuously during the day during the winter months. This cathedral has created an internal environment, which is independent of the outside environment.

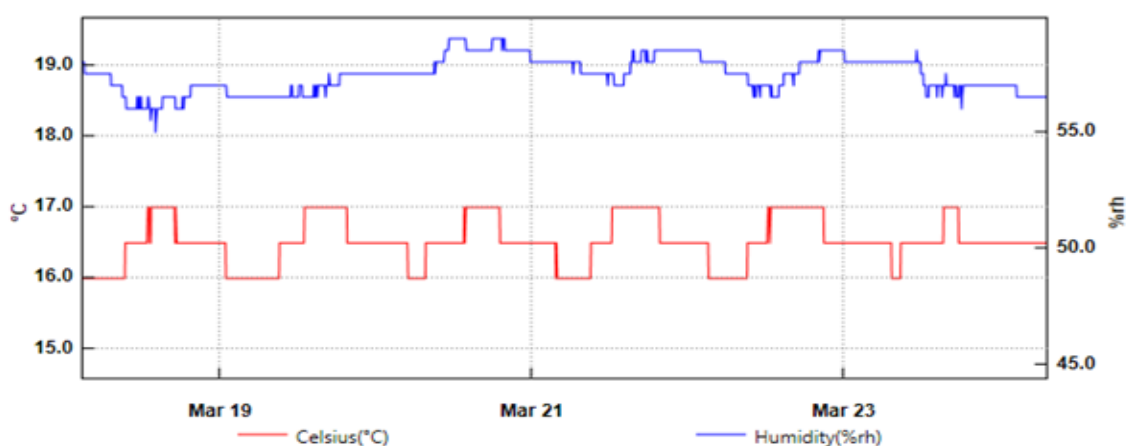

Figure 5.127 - St. Patrick's cathedral, Dublin, Logger 1, from March 18 to March 24, 2015

They also maintain the heat at a relatively high ambient T of 17°C. The RH figures are low and people may have an influence here due to very high visitor numbers.

Figure 5.128 shows an LPHW system used intermittently. This cathedral actually also has an underfloor system but chooses, for cost reasons, not to use it.

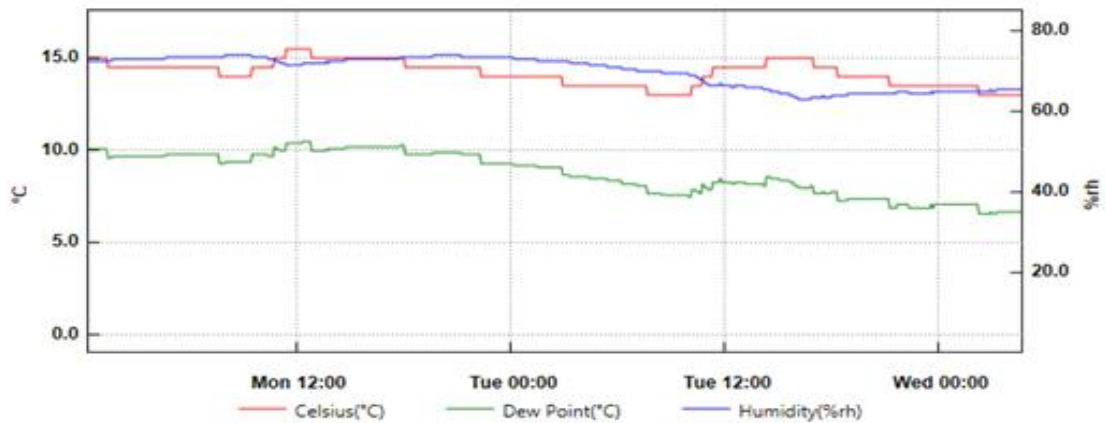

Figure 5.128 - Logger CS1 Winter in St. Patrick's cathedral, Armagh (RC). T, DW and RH readings from Oct. 31st to Nov. 2nd, 2016

The LPHW system in this cathedral is switched on for two hours every day during the winter and hence is susceptible to the outside environment and a prolonged period of cold weather will reduce the internal T and raise the internal RH. The boilers are modern and quite capable of raising the T further but as they are restricted by time rather than influenced by the outside T, the result is that the inside environment is very much influenced by the outside environment.

Figure 5.129 shows an LPHW system which is only switched on for Sundays which is common in CI cathedrals.

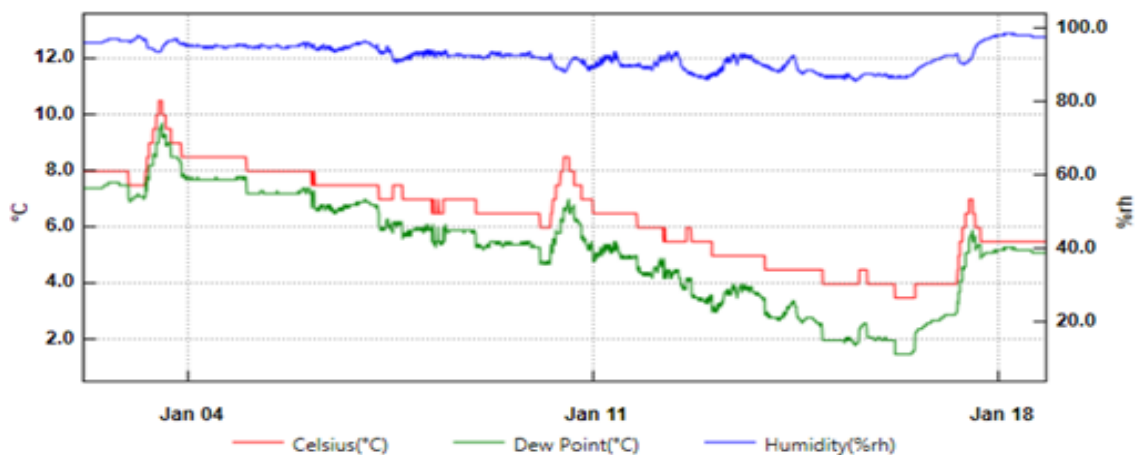

Figure 5.129 - T, RH and DW readings for Logger 15 in St. Brigid's cathedral (CI), Kildare. From Jan. 2nd to 18th 2016

This cathedral only switches the heat on for the one service which it holds on a Sunday. In January 2015 the Sundays were on 4, 11 and 18 as shown. The warm up time is quite fast but the slow cool down time shows that the whole building is being heated and that the thermal mass of the building is holding the heat and slowly releasing it, which means that a lot of this heat is wasted. They have a

congregation on a Sunday of some 15 to 20 people. The gradual reduction in the inside T was as a result of a reduction in the outside T.

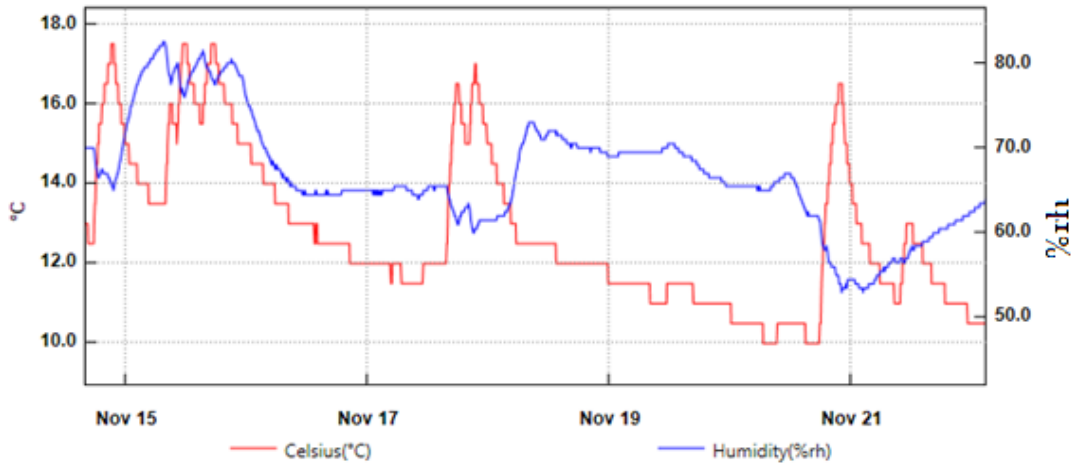

Figure 5.130 - Logger 10 T and RH readings for St. Columb's cathedral, Derry. From: Nov 14th to 22nd 2015

In the cathedral results shown in Figure 5.105 the LPHW system is backed up with another system, namely a hot air blower which means that although the heating is only on for Sundays and much heat is lost during the week, the ambient T on Sundays is quite stable, unlike in Kildare. The slow cooling down means that they are heating the building and the thermal mass slowly releases the heat and this is wasteful of energy. Further research is required to establish how much each system contributes to the overall effect.

This cathedral achieves a fast warm up time and a short cooling down time as the building itself is not allowed to warm up. The heating is switched on every day for a short period. The outlet for the hot air is at a height of approximately 3 metres and is situated in the sanctuary. No other cathedral in Ireland achieves such fast warm up rates as this building does. Again, further research should be carried out to establish the contribution which each heating system makes to the overheating in the cathedral.

Figure 5.131 shows a hot air blower system backed up by small electric radiant heaters

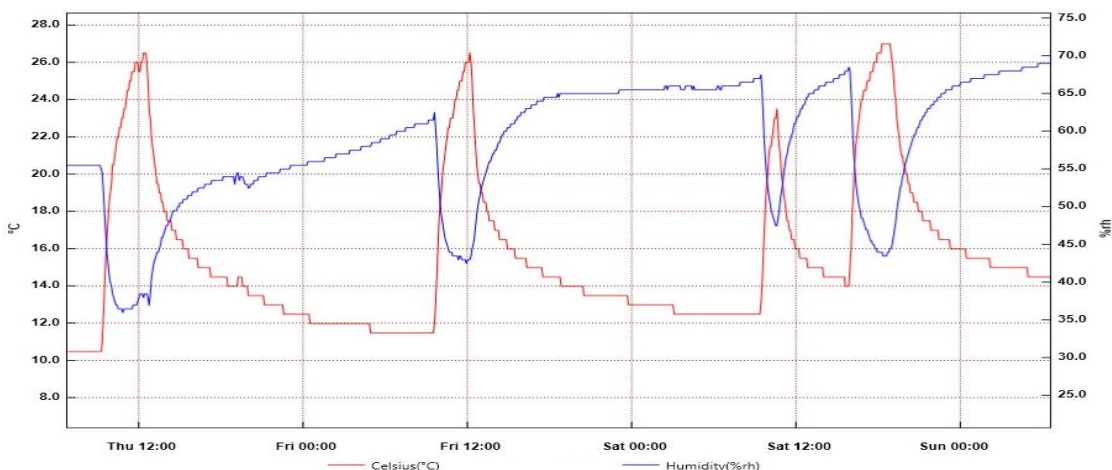

Figure 5.131 - T and RH readings from Feb. 18th (Thu) to 21st (Sunday) for Logger 13 in St. Mary's cathedral, Cork

In Figure 5.132 an underfloor with trench heating system is the next profile to be examined but it is no known how much each system contributes to the whole.

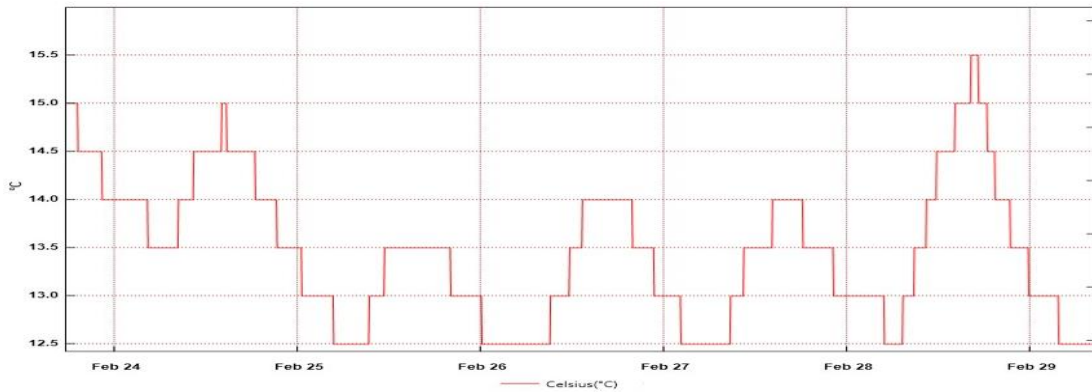

Figure 5.132 - T and RH readings for Logger 2 from (Tue) Feb. 23rd to (Monday) 29th 2016 in St. Fin Barre’s cathedral, Cork

In this cathedral the underfloor heating is kept on most of the time, hence the stable ambient T. The heating is then boosted on Sundays, as it can be observed on the highlighted section of the graph, which shows the T_{max} on Sunday (28th) reaching 15.5°C due to the addition of the trench heating, turned on weekly at around 5pm.

If an underfloor system is left on all of the time, which is when they are most effective then the following profile is produced.

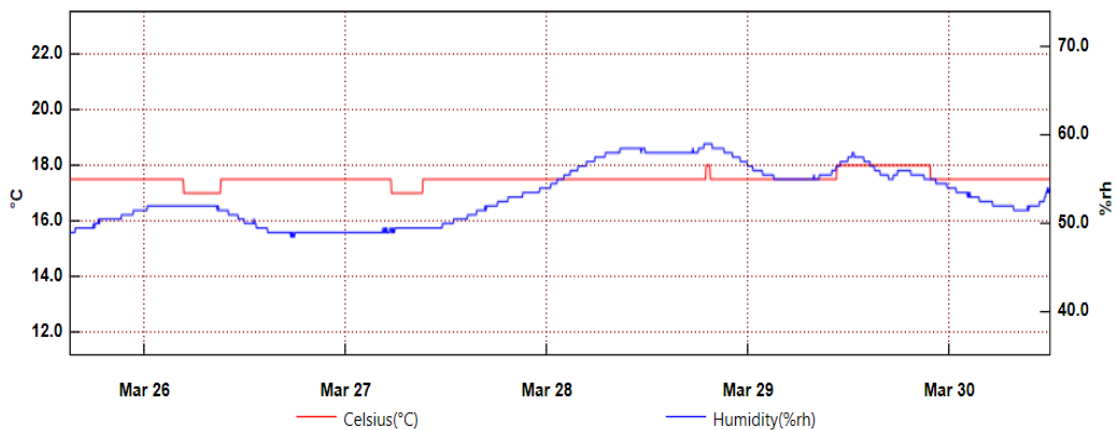

Figure 5.133 - Logger 20 readings for T and RH in Galway cathedral. From March 25th (Wed.) to 30th (Monday) 2015

It can be observed from this graph that the system and regime used keeps a stable temperature with no need for a boost on Sundays. The system runs continuously and it is able to keep the ambient T quite high (18°C on average), due to the roof insulation fitted to this cathedral, which is responsible for diminishing the heat dissipation inside the building.

5.6 Observations and Conclusions

For the sake of clarity, the size of the cathedrals was taken as the primary indicator for these results analysis. However it emerges that size is not the dominant determinant which affects the internal environment of Irish cathedrals and other factors such as location, construction, heating systems and regimes and particularly usage are all contributors, with varying degrees of influence. The importance of air movements within cathedrals is fully acknowledged as being very important when looking at the internal environment within cathedrals. However, measuring the air movements was beyond the scope of this thesis.

The different heating profiles produced by the various heating systems such as underfloor, LPHW and intermittent LPHW can be seen in Section 5.2 Gradients for differing heating regimes and types found in Irish cathedrals in this chapter. Where it can be afforded, such as in St. Patrick's cathedral (Figure 5.127), this method of heating produces a high level of thermal comfort and a completely independent internal environment, quite separate from the external environment. Figure 5.128 shows that when the heating is turned on for an insufficient set time, the internal environment can be highly influenced by the external environment. Figure 5.129 and Figure 5.130 show the amount of heat lost by intermittently used LPHW systems which are only switched on for Sunday services. Figure 5.131 shows the very sharp rises and falls of the hot air blower system but further research is needed to understand the contribution which the hot air blower system and the small radiant heaters have in this cathedral. Figure 5.132 shows an underfloor system boosted by trench heaters which is the same system that has been installed in the newly built St. Mel's cathedral in Longford. Finally, Figure 5.133 shows the effect of a well-insulated building equipped with a constantly operated underfloor system, the profile is flat with small movements in T and RH.

5.6.1 Temperature

In respect of temperature profiles, the following conclusions may be drawn:

- Of the 25 monitored cathedrals, 23 heat the whole air mass in the buildings and not just the people inside the buildings. Of the 57 cathedrals, 93% heat the whole building and not just the people in the building. The 2009 EU funded Friendly heating Project showed that intermittently used and heated churches should heat the people with local heating rather than heating the whole building.
- The fastest rate per hour increase is achieved by those cathedrals which use hot air heating systems. This is good because little heat is wasted and it is likely to be cheaper to run than heating all of the air within the building.
- Of the 25 monitored cathedrals, 14 cathedrals have the heat on for a set time each day and 11 cathedrals set their heating to achieve a particular temperature. Those that have the heat

on for a set time each day are more susceptible to changes in the outside environment than those which do not. The suitability of each system will depend on a number of factors but particularly usage.

- Only two cathedrals, namely St. Mel's and Galway, are known to have any type of insulation. The beneficial results of this are clearly shown in the very stable figures achieved in these cathedrals.
- Intermittently heated cathedrals which are heated long enough for thermal mass to be relevant can waste heat during the period when the buildings are unoccupied.
- The lowest recorded internal temperature during the monitored period was 3.5°C and the highest internal temperature recorded was 25°C.
- The largest upward movement in temperature within a one hour period was 15°C. This represented a movement from 10°C to 25°C and was achieved with a hot air blower system. This large range may present problems with regard to thermal shock and the contents of the building.
- The Institute of British Organ Building state that for the 'safety' of pipe organs, heating should not exceed 20°C when the building is in use and should not be below 10°C when the building is unoccupied. 16 of the 25 monitored cathedrals exceeded these parameters at least once during the monitoring period. Kildare CI cathedral was one of those cathedrals, but it has its pipe organ enclosed in a separate environmentally controlled chamber, uniquely. This enables the organ to be isolated from the internal environment of the building.

5.6.2 Moisture

In respect of moisture conditions in the monitored cathedrals, the conclusions are:

- Of the 25 monitored cathedrals, 14 recorded relative humidity (RH) levels in excess of 80% on at least one occasion during the monitored period.
- The lowest internal RH figure recorded was 28% and the highest was recorded as being 100%. These figures are given to show the large range which was achieved.
- Large numbers of damp people entering a cathedral does have a direct effect on internal RH levels.
- Those cathedrals which set heating to come on for a particular time allow internal RH levels to be more closely match external RH levels, following the trends in T inversely. This may save money but as shown in St. Patrick's RC cathedral Armagh, may result in unacceptably low levels of thermal comfort.

- Some cathedrals, at a cost, ensure that internal RH levels are completely separate from external RH levels. This is good for the building and its contents provided that the level of T is not excessive. Only those cathedrals with substantial tourist income can afford to maintain constant high T levels.
- Highly pervious buildings or those which leave the doors open all day are very susceptible to changes in external RH levels.

5.6.3 Sunday Services

The average temperatures (T) inside the monitored cathedrals for Sunday services were as follows:

Church of Ireland (CI) 14.5°C

Roman Catholic church (RC) 16.5°C

CIBSE Guide (2015) gives a recommended T figure for thermal comfort inside used churches of 18°C (with activity metabolic rate of 1.3 and clothing/clo of 1.2).

This difference on average T illustrated above is due to RC cathedrals have services every day and the heating is switched on commensurately and thus the buildings have a generally higher ambient T than CI cathedrals.

From the calculations in Table 3.5 it can be seen that, taking the average figures, only two cathedrals reached the recommended figure of 18°C over all of the monitored Sundays. 13 cathedrals had an average Sunday T of less than 15°C and 4 less than 10°C. As T is normally higher on Sundays than for other days of the week this means that most cathedrals are not providing adequate levels of thermal comfort.

Historic England who help to look after the 42 Church of England cathedral have stated that there are no recommended T levels for their cathedrals as each building is so different and must be treated on a case by case basis.

Table 5.6 - Average internal T on Sundays and the correspondent standard deviation for each cathedral

	Cathedral		Logger	T	Std Deviation
Armagh	St. Patrick's Cath. - Winter	RC	CS5	12.70	1.48
	St. Patrick's Cathedral - Summer	RC	CS1	17.05	0.66
Galway	St. Nicholas	RC	20	17.63	0.35
Belfast	St. Anne's Cathedral	Col	20	11.88	1.20
Dublin	St. Patrick's	Col	4	17.00	0.08
Kilkenny	St. Canice's - Summer	Col	7	19.36	0.85
	St. Canice's - Winter	Col	21	12.09	1.57

Cathedral		Logger	T	Std Deviation	
Dublin	Pro Cathedral	RC	2	16.40	0.99
Limerick	St. Mary's	Col	4	15.90	1.89
Killarney	Assump the Blessed Virgin Mary	RC	CS2	14.90	1.95
Longford	St. Mel's	RC	11	16.20	0.29
Cork	St. Fin Barre's	Col	9	12.58	0.91
Dublin	Christ Church Cath. - Summer	Col	14	20.80	0.67
Dublin	Christ Church Cath. - Winter	Col	CS4	17.81	0.88
Belfast	St. Peter's Cathedral	RC	13	15.05	1.81
Kilkenny	St. Mary's	RC	9	9.44	1.98
Cork	St. Mary & St. Anne Cathedral	RC	15	14.26	1.31
Armagh	St. Patrick's Cathedral	Col	CS4	12.50	2.01
Derry	St. Columb's	Col	9	14.95	1.12
Carlow	Cath. of the Assumption	RC	19	17.98	0.73
Enniskillen	St. Macartin's	Col	CS4	14.30	1.08
Kildare	St. Brigid	Col	16	8.31	1.73
Killaloe	St. Carthage's	Col	8	14.24	1.03
Lismore	St. Carthage's	Col	CS3	7.43	0.99
Loughrea	St Brendan's Cathedral	RC	13	17.53	0.98
Old Leighlin	St. Laesarian's Cathedral	Col	8	9.70	1.00
Raphoe	St. Laesarian's Cathedral	Col	21	15.90	0.49
Skibbereen	St. Patrick's Cathedral	RC	40	16.23	0.82

The Institute of British Organ Builders (IBO) issue guidelines for T and RH readings for the protection of pipe organs (IBO, 2003). During the heating season it is recommended that RH is kept in the band of 55 to 75%. For T when the building is unoccupied they recommend not to exceed 10°C (provided the building is not damp) and if the building is occupied then T should not exceed 20°C. In the table below, the cathedrals which did not exceed the recommendations more than twice during the monitoring period are marked on green (see notes on the bottom of the table).

Table 5.7 - IBO recommended parameters for the protection of pipe organs

CATHEDRAL		T (≥20°C)	RH (55% to 75%)
ROMAN CATHOLIC			
Armagh	St. Patrick's Cath. - Winter	✓	⊘
Galway	St. Nicholas	✓	⊘
Dublin	Pro Cathedral	⊘	
Killarney	Assumption of the Blessed Virgin Mary	✓	⊘
Longford	St. Mel's	✓	
Belfast	St. Peter's Cathedral	✓	✓
Kilkenny	St. Mary's	⊘	⊘
Cork	St. Mary & St. Anne Cathedral	⊘	⊘
Carlow	Cath. of the Assumption	⊘	⊘
Loughrea	St Brendan's Cathedral	⊘	⊘
Skiberreen	St. Patrick's Cathedral	✓	✓

CHURCH OF IRELAND			
Belfast	St. Anne's Cathedral		☒
Dublin	St. Patrick's	☒	☒
Kilkenny	St. Canice's - Winter	✓	☒
Limerick	St. Mary's	✓	☒
Cork	St. Fin Barre's	✓	☒
Dublin	Christ Church Cath. (CCC) - Winter	✓	☒
Armagh	St. Patrick's Cathedral	✓	☒
Derry	St. Columb's	☒	☒
Enniskillen	St. Macartin's	✓	☒
Kildare	St. Brigid	✓	☒
Killaloe	St. Carthage's	✓	☒
Lismore	St. Carthage's	✓	☒
Old Leighlin	St. Laesarian's Cathedral	✓	☒
Raphoe	St. Laesarian's Cathedral	✓	☒

Note¹: The cathedrals are only marked when they exceed the recommendations (55 to 75% RH and 20°C T) more than twice during the monitoring period.

Note²: all RC cathedrals are open every day, therefore the unoccupied rule (>10°C) does not apply to them.

Note³: Some CI cathedrals are open daily for visitors, and the unoccupied rule does not apply to them.



does exceed the recommended parameters



does not exceed the recommended parameters

6 Conclusions and Recommendations

6.1 Summary of work completed

The work which was completed, and which has resulted in these conclusions and recommendations, was undertaken in a number of phases as follows:

- Phase 1** Obtaining background information from all pertinent publications relating to temperature and humidity, thermal comfort and conservation/preservation, in large historic buildings,
- Phase 2** Obtaining background information on all 57 active cathedrals.
- Phase 3** Preparing the questionnaire to be used during the visits to the cathedrals and planning the visits.
- Phase 4** Visiting all of the 57 active cathedrals. This work continued during phases 5, 6, and 7.
- Phase 5** Choosing 25 representative cathedrals to be monitored and choosing and procuring the equipment which would be used during the monitoring phase.
- Phase 6** Installing the equipment.
- Phase 7** Removing the equipment and preserving the data.
- Phase 8** Analysing the data and developing conclusions and recommendations.

The purpose was to establish as much relevant information as possible about the cathedrals in Ireland including such items as age, size, location, usage, types of heating and heating regimes and religious tradition, with the object being to establish if some cathedrals could be grouped together, taking all of the parameters into account, to establish if recommendations with regard to heating could then be composed. All of this information which was gathered was new and as set out in the Aim and Objectives.

Each of the phases was required in order to meet the first two objectives as set out in page 8. The first objective required that a 100% response was obtained from the questionnaire and this was achieved. The fact that not all of the information requested in the questionnaire was available, on site, was a limitation and surprising outcome of the research. The lack of information has however, as set out in Chapter 6, presented opportunities to the owners and managers of the cathedrals to improve their management structures and information systems whilst at the same time, possibly, achieving better performance from the existing heating systems with the potential to save money. The funds saved could then be used for maintenance and repairs amongst other things.

The second objective was met, particularly by phases 5 to 8 and accurate data was collected for 25 of the 57 cathedrals in Ireland concerning the internal thermal and hygrometric environment within the cathedrals. It is acknowledged that a limitation of the research was that air movements within the buildings were not measured but this was outside the scope of this research. The research suggested that objective three namely to see if it is possible to group similar cathedrals together and to suggest an optimum heating solution, may not be possible due to the variety of buildings and their heating systems. Further research has been suggested and as a result of this it may be possible to suggest an optimum heating systems or combination of heating systems for a particular group of cathedrals with similar characteristics. However few cathedrals could afford to remove an old and perhaps unsuitable heating system and install a completely new system even if the new system was more appropriate to current usage patterns in the cathedral. A new heating system is likely only to be considered at a time of major refurbishment.

All of the phases in the summary of work completed added to the almost non-existent knowledge base about heating systems in Irish cathedrals. Whilst a limitation of the research could be that information was not available, on site, to complete the questionnaires fully, most of the information which was obtained was new and form the basis for developing a data base for Irish cathedrals. The data collected from the loggers was also entirely new and provides a large quantity of accurate data concerning the internal environment within 25 cathedrals.

6.2 Main observations

6.2.1 Information

The following observations can be made

- Much of the information which could have improved the understanding of the operations of the heating systems, was not available, for a variety of reasons This meant that those charged with the day-to-day running of the cathedrals did not always have all of the information necessary for them to carry out their functions properly, or as they would have wished. Follow-up emails and telephone calls were made to various cathedrals to expand on the information received during the site visits but, as stated elsewhere, in some cases the information required is known by a variety of different people who were not usually available for interview, whilst in other cases the information was not known. This is an extremely inefficient way to operate these buildings.
- There appeared to be no knowledge sharing amongst the cathedrals which resulted in good potential solutions not being communicated to others with the resultant loss of efficiency and effectiveness and almost certainly giving rise to increased costs.
- Only two cathedrals are known to have any type of insulation installed. In most cases it was not known, by the interviewees, if insulation was present, but it is unlikely in most cases.

6.2.2 Heating systems

In relation to heating systems the following observations can be made:

- Over 90% of Irish cathedrals heat the whole air volume in the buildings and do not use local heating which would heat only the people in the buildings.
- Some heating systems are not being operated as they were designed to operate, in order to save costs.
- There was no indication that any Irish cathedral has plans to include renewable energy as part of a long term strategy to address climate change.
- Some heating systems are obviously well maintained with maintenance contracts in place but many others are not so well maintained with possibly a loss of efficiency and increased fuel costs, as a result.
- Different heating systems produce different heating profiles as follows:
 - **Underfloor heating** This produces, if used as designed, a more even spread of T and RH throughout the building. Rate per hour increases tend to be smaller. It is not suitable for intermittent use as it is slow to warm up and cool down and therefore wastes heat if used in this way. Galway cathedral is a good example of this system being well used. Limerick cathedral shows the above-mentioned attributes. Underfloor systems are often augmented with either trench (Longford, Armagh) or LPHW (Cork CI) systems. This enables the underfloor system to provide a low level of T which can be boosted by the alternative system, for services. In a number of cases these systems are used intermittently and this is not an optimum use of this type of heating system due to the slow warm up time. Ideally this type of system is kept on continuously to provide low level heating which is then boosted with for instance an LPHW system for services and other events.
 - **LPHW**, which is the most commonly used system in Irish cathedrals, depends on the efficiency of the boiler and the radiators for its effectiveness. If the boiler is too small or old and inefficient then the rate per hour increase can be very slow and the system often fails to provide a satisfactory level of thermal comfort. Kildare cathedral is an example of this where the pipe work and radiators are old and inefficient. If the system is used intermittently then there can be waste a of energy as the building has heated up, over several hours of heating and may take days, when the cathedral is empty, to cool down. St. Columb's cathedral in Derry is an example of these phenomena. If the system is set to be on for a particular period, rather than to achieve a particular T, then the inside T and RH readings tend to follow the outside T and RH readings, which may not always be beneficial particularly during prolonged

periods of cold weather. These systems can be used intermittently but the risk here is wasted heat if the system has to be operated long enough to heat the building and the heat is then slowly released during the week when the building may be unoccupied. These central heating systems heat the whole volume of air within the building and heat it from the top down which is not suitable for intermittently used and heated buildings.

- **Radiant heaters** generally heat the people in the cathedral and not the fabric of the building. However those not sitting in the path of the waves may not feel any benefit. Lismore and Belfast are examples of this type of heating. This type of heating is suitable for intermittent use and small congregations. However they rarely supply adequate levels of thermal comfort.
- **Hot air blowers**, if used for a short period, they can provide a very fast heating up time and, because the fabric of the building is not being heated, a fast cooling time. Cork (RC) cathedral is a good example of this type of heating but it is augmented in that cathedral with small electronic radiant heaters. Further research is needed to establish the suitability of these systems for a variety of buildings. They may be noisy and expensive to run but perhaps in conjunction with another system may provide a good solution for intermittently used buildings. Stratification is known to be an issue with these systems as is the movement and deposit of pollutants.

All heating systems are influenced by factors such as:

- The heating type.
- The power of the heat delivery system.
- The efficiency of the heat delivery system.
- The size of the building.
- The outside T and RH readings.
- The porosity of the building envelope.

6.2.3 Fuel used

- There appeared to be no co-operation or collective bargaining in the purchase of fuels. By not using the obvious purchasing power which so many buildings have, this leads to unnecessary costs for individual cathedrals.
- There appeared to be no particular reason why certain fuels were used and not others, unless certain fuels were not available on the sites, or due to storage issues. Gas is generally cheaper to purchase than oil and it is evident that many cathedral still run their heating systems using oil.

- There is almost 100% dependency on fossil fuels for heating the cathedrals in Ireland; it is possible that some electricity is derived from renewable sources, but this is not known.

6.2.4 Controls

- There was little evidence of heating controls being installed in the cathedrals, except for timers, and this prevented options such as zoning and feedback being carried out to cater for differing numbers using the buildings at different times, or different internal ambient temperatures.
- Few thermostats were observed as being installed or used.
- A building management system was observed as being installed in just one cathedral. An additional system was being installed during the research period in another cathedral.
- There was no evidence that those charged with the day-to-day running of the cathedrals have been instructed in the use of these systems and how to get the best outcomes from them.

6.2.5 Maintenance

- Some cathedrals have T and RH readings which would prove damaging to the pipe organs installed and to the buildings and their contents.
- Some cathedrals produce T readings for Sunday services which are below 10°C and, whilst there are no recommended T readings for churches, this level of heat would not provide adequate thermal comfort. Other cathedrals regularly have temperatures during services in excess of 18°C during the heating season which is unnecessary and inefficient.

6.2.6 Other observations

- No targets have been set for reductions in either green-house gas emissions or CO₂.
- There is a great deal of diversity found in these cathedrals in terms of size, age, location, usage and heating solutions, which results in no one solution to the heating issue being applicable to all or indeed to most of the buildings.
- There is a lack of knowledge about the systems installed and how they should operate for maximum efficiency. There is also a lack of knowledge regarding the running cost of the systems and also about the carbon costs.
- The majority of cathedrals fail to deliver a suitable environment for occupant comfort or within bands of acceptable T and RH for conservation and preservation.
- Accurate numbers attending events and services in RC cathedrals are not known and are therefore not analysed. Whilst these numbers exist in some form for CI cathedrals there was no evidence that they are being analysed regularly and used to adjust energy requirements.

6.3 Key conclusions

The following key conclusions are noteworthy:

- 52% of Irish cathedral are owned by CI and 48% by RC church. RC cathedrals are open every day and most CI cathedral are only open on Sundays giving very different usage patterns and energy requirements
- Irish cathedrals are almost 100% fossil fuel dependent.
- There are no overall budgets or other plans for the reduction of carbon emissions.
- No Irish cathedrals are actively considering alternatives to the use of fossil fuels.
- Most Irish cathedral do not provide an adequate levels of thermal comfort during services and most do not fall within the guidelines for T and RH for the conservation and preservation of the buildings and their contents.
- There is no evidence of knowledge sharing amongst Irish cathedrals leading to a loss of good ideas and almost certainly, increased costs.
- There is no collective bargaining for the purchase of fuels which, almost certainly, leads to substantially increased costs for individual cathedrals.
- There is a lack of information about the heating systems installed in the cathedrals and how to maximize their performance.
- There does not appear to be a planned maintenance programme for heating in most cathedrals.
- There is no one heating solution which would be applicable to all or even most cathedrals.
- The management systems in relation to heating and energy use are for a variety of reasons, dysfunctional in nearly all cathedrals

6.4 Achievement of Objectives

In discussing if the objectives were achieved it is necessary also to restate the objectives as set out in Chapter 1. 2.

Objective 1: To compile a data-base of each of the 57 active cathedrals in Ireland, by carrying out an onsite survey of each cathedral using a detailed questionnaire. The survey will include details of the heating systems within the buildings, the type of fuel used and how the buildings are used, amongst other details.

Achievement of objective 1: Each of the 57 cathedrals was visited and surveyed and 100% of the questionnaires were returned. A detailed data-base of many aspects of the buildings was compiled which added to the existing knowledge available about these buildings.

Objective 2: To monitor the internal and external temperature and relative humidity, over a period of at least one month, in a representative sample of the 57 cathedrals to record details about the internal thermal environment. Three of the above cathedrals will also be monitored when the heating is off to determine how quickly these buildings react naturally to changes in the outside environment in both winter and summer.

Achievement of Objective 2 A representative sample of 25 cathedrals was chosen and monitored and over 2.4 million pieces of data were collected from the internal and external data loggers. Such monitoring had not been carried out before in so many cathedrals and a substantial increase in the knowledge about these buildings was the result. Each of the cathedrals which were monitored in the winter months was sent a comprehensive package of the results in the hope that they might prove to be of assistance. As a result of this data gathering exercise it was possible, after analysing the results, to arrive at a set of conclusions and recommendations for some of the cathedrals or about cathedrals in general.

Objective 3: To identify if it is possible to group cathedrals in Ireland, which are of similar size, age, usage, construction, tradition and location to deduce if a particular heating system and regime might be more or less suitable for them with regard to thermal comfort, conservation and preservation.

Achievement of Objective 3: The existence of a much wider diversity of heating systems and regimes became evident as a result of the analysis of the data collected. It became clear and as has been stated by a number of other researchers, that there is no one solution that suits all cathedrals. It is for this reason and others that there are no recommended T ranges for thermal comfort in these buildings as each building has to be treated on a case-by case-basis. Further research, as outlined in Section 6.5 below, is necessary before it will be possible to determine if groups of similar cathedrals can be identified and recommendations made as to the best heating solution for them.

Contribution to the field of existing knowledge.

The achievement of Objectives 1 and 2 have added greatly to the existing knowledge base in the area of church and cathedral heating and the internal environment created by the various types and heating regimes. All of the data gathered was new. Objective three was not achieved in the sense that it was not possible to group a number of cathedrals together and try to ascribe a particular heating system and regime to them. This was because of the number of variables involved and the great variety of buildings and heating systems found in Irish cathedrals. This would not have been known if the data had not been collected, collated and analysed which enabled the observations and conclusion to be made and drawn as set out in Chapter 6.

6.5 Recommendations for further research

Based on the data collected, it is possible to make certain recommendations for further research as follows:

- St. Mel's cathedral in Longford, which is the newest cathedral in Europe, has a modern heating system with the latest BMS and heating controls. In addition, it is well insulated in both the ceiling and the floor. The data collected showed that this cathedral maintained reasonable levels of thermal comfort as well as a stable internal thermal environment. It is felt that if it was possible to monitor this cathedral, which in terms of its usage patterns, heating system (underfloor and trench) is typical of many cathedrals, then much valuable data could be collected since the results it achieved were unlike other cathedrals using a similar system. Ideally the building would be monitored for a full year and full costings of the running the system would be made available. More loggers would ideally be used than was used in this research and they would be placed at various heights within the building to see if stratification was an issue. In addition the new pipe organ should be closely monitored to establish if the heating system was providing a suitable environment for the instrument.
- St. Mary's cathedral in Cork achieved much faster heating and cooling times than any other cathedral in Ireland with its hot air blower system backed up by small electric radiant heaters. Further research is recommended to find out how much each of these systems contributed to the internal thermal environment. It would be helpful to know full details of the boiler system and the costs of running the system. This information could then be used by any cathedral considering replacing or augmenting their heating system to see if the system in St. Mary's might be suitable. As with St. Mel's, more loggers should be employed in any further research in particular to establish if stratification is an issue since hot air blower heating systems are known to produce this phenomenon.
- Further research is required to analyse the use of underfloor heating systems to research the ideal T setting for these systems and the efficiency or otherwise of their intermittent use.
- Most Irish cathedrals use LPHW systems and further research is recommended to analyse the contribution each element of these systems makes to the overall internal thermal environment. In other words to establish if, given the various parameters, there is an ideal size and power of boiler and type of radiator which will give maximum return on the investment and the money spent on energy use and still produce adequate levels of thermal comfort and be within the recommended limits for conservation and preservation. Also it would be valuable to explore if existing systems can be enhanced without major capital expenditure.

- Research is required into renewable energy sources for use in Irish cathedrals. Most cathedrals have large South facing roofs which at present produce no energy. With the aesthetic problem being overcome with the development of roof solar panels which look like roof tiles, and with battery technology enabling increasing amount of electricity to be stored for longer, these types of systems need to be analysed in depth.
- Further research is recommended into the effects of thermal mass in cathedrals. Thermal mass is generally considered to be beneficial but it may not be so when heating systems and buildings are used intermittently. The use of some of the cathedrals has changed substantially in recent years and further research is recommended to understand how thermal mass might best be utilised in these cases in order to reduce the amount of energy used.
- It is recommended that further research be carried out in relation to heat loss from cathedrals. If it could be established where heat loss is greatest then, in the event that remedial work is possible, those areas of greatest heat loss could be addressed first, assuming that conservation and preservation issues could be accommodated. For example it is generally accepted that in residential properties the majority of the heat is lost through the roofs. In cathedrals this may not be the case. Single glazing is very prevalent and is likely to be a strong influence on heat loss.
- It is recommended that an energy audit should be carried out in each cathedral using smart meters and software such as sMeasure©. This would provide vital information to the cathedral managers concerning energy use and may enable substantial cost savings to be made.
- Some heating systems are not being used in the way in which they were designed. The relevant cathedrals should carry out research to ensure that they are in fact saving costs by understanding the original design parameters.
- Some heating regimes are inadvertently causing damage to the pipe organs. Research should be carried out to see if it is more cost effective to retune the organ on a regular basis or to adjust the heating regime.
- Those cathedrals which do not have maintenance contracts should carry out research to establish if this is cost effective.

6.6 Recommendations for cathedrals

In addition to research recommendations, it is deemed appropriate to offer practical recommendations to the managers and owners of the cathedrals thus:

I. Centralised Policy

- A comprehensive survey of all of the heating systems should be undertaken to ensure that they are operating at maximum efficiency. Available software should be obtained to assist in this.
- An interfaith, all Ireland policy and strategy plan should be drawn up to reduce heating costs both financial and carbon, in cathedrals and churches.
- A forum should be set up centrally so that best practice ideas can be shared amongst the managers of the buildings.
- The purchasing of fossil fuels, where necessary, should be done centrally to benefit from the obvious buying power which such a large real estate portfolio generally gives.
- Realistic targets for the reduction of green-house gases and carbon emissions should be set, centrally, with a proper annual reporting structure incorporated.

2. Technology

- Simple heating controls should be installed in the existing systems, so that zoning of the building can be achieved, where this is appropriate.
- Thermostats should be installed where appropriate, with temperature feedback and appropriate set points.
- A BMS should be installed in those cathedrals with the largest energy usage to ensure maximum efficiency in the use of that energy.

3. Solutions

- For those cathedrals which use their heating system intermittently, perhaps only for Sunday services, and which have small congregations, consideration should be given for installing local heating solutions. The main (usually LPHW) systems could, if finance permits, be kept operational for the times when the cathedral is full, such as at Christmas and Easter and for large weddings and funerals, but the local heating could be used at other times.
- Many cathedrals should consider the installation of roof/ceiling insulation, where possible, and under the supervision of experts to avoid condensation issues, in cathedrals which do not have insulation.
- Some cathedrals should be considering the use of renewable energy when their existing systems need replacing or if they decide they are able to make ecologically beneficial changes to their existing systems. Critically it should be ensured that they have the necessary information needed to make an informed decision.

- Energy audits should be carried out in all cathedrals with reports being sent back to a central body for analysis.
- Realistic targets need to be set and annual reports submitted centrally regarding costs and carbon footprint reductions.
- Accurate data on the numbers using the cathedrals should be gathered and the data should be reported back to a central body for analysis. Taken together with accurate financial data it will then be possible to calculate, amongst other things, how much it costs per square meter and per person in each cathedral. This data can then be compared between all cathedrals and those in the UK, to ensure best performance.
- It is impractical to suggest, for cost reasons as much as anything, that inappropriate heating systems be replaced with more suitable ones in the immediate term. Moreover when the time comes when a heating system or part of it needs to be replaced, there is a need to produce guidance centrally into what sustainable choices are available for selection, depending on location, size and use and budget. It is likely that time spent with a suitably experienced heating consultant would be time and money well spent to ensure that future heating systems are running at maximum efficiency and with the lowest carbon footprint that is practical.
- A comprehensive training programme should be introduced for those with responsibility for running the heating systems.
- Proper documentation should be kept in the cathedrals, such as service manuals, for each heating system and indeed for all aspects of the building.
- Cathedrals should consider pooling their resources to purchase the necessary monitoring equipment and to pay a professional to oversee a large group of cathedrals. However this would be much better done centrally by the owners of the buildings.

With so few cathedrals producing acceptable levels of thermal comfort and with RH levels outside acceptable levels for conservation and preservation of the buildings and contents, it is felt that these matters should be addressed as a matter of urgency. It is felt that the implementation of all or some of these recommendations will add both to the existing knowledge base in the area of heating of heritage type buildings and also to the field of heating and internal environments of cathedrals in Ireland. There is still much to be researched in this area and it is hoped that this current research will act as a catalyst for this further research especially in a time of falling incomes and increased costs in cathedrals but also in a time of opportunity presented by innovations in renewable energy and energy storage.

REFERENCES

- ARCHDIOCESE OF ARMAGH. 2014. St. Patrick's Cathedral Armagh. Available: www.armagharchdiocese.org [Accessed 14 August 2014].
- ARENS, E., HUMPHREYS, M. A., DE DEAR, R. and ZHANG, H. 2010. Are 'class A' temperature requirements realistic or desirable? *Building and Environment*, 45, 4-10.
- ARNOLD, A. and ZEHNDER, K., 1990. Salt weathering on monuments. In Zezza, F. (ed), *The Conservation of Monuments in the Mediterranean Basin*. 31-58. (Grafo, Barri).
- ARNOLD, P. 2013. Thinking yourself warm; or how to approach heating traditional buildings. *Energy Efficiency in Historic Houses*.
- ASHRAE 2001. Available: www.ashrae.org [Accessed 25 February 2016].
- ASHRAE 2004. ANSI/ASHRAE Standard 55-2004. *Thermal Environmental Conditions for Human Occupancy*. Atlanta, Georgia. American Society of Heating, Refrigeration and Air Conditioning Engineers (ASHRAE).
- ASHRAE 2009. *ASHRAE Handbook: Fundamentals*, Atlanta, G.A.: American Society of Heating, Refrigeration and Air Conditioning Engineers. (ASHRAE).
- ASTE, N., TORRE, S. D., ADHIKARI, R. S., PERO, C. D., LEONFORTE, F. and MANFREN, M. 2016. Sustainable church heating: The Basilica di Collemaggio case-study. *Energy and Buildings*, 116, 218-231.
- AULICIEMS, A. and SZOKOLAY, S.V. 2007. *Thermal Comfort (2nd edn.)*. London: Passive and Low Energy Architecture (PLEA). Available: www.plea-arch.org. [Accessed 12 May 2017].
- BAKER, N.V. and STANDEVEN, M.A. 1996. A behavioural approach to thermal comfort assessment in naturally ventilated buildings, in *Proceedings of the CIBSE National Conference*, Eastbourne, Chartered Institute of Building Engineers, London. 76-84.
- BALARAS, C.A. 1995. The role of thermal mass on the cooling load of buildings. *Energy and Buildings*. 24, 1-10.
- BBC News. (2014). Available: www.bbc.com/news/world-europe. [Accessed 10 July 2017].
- BECK, W. and KOLLER, M. 1980. Problems of heating within historic buildings of Austria. Preprints, IIC Vienna Congress (1980). 22-29.
- BEDFORD, T. 1950. Environmental Warmth and Human Comfort. *British Journal of Applied Physics*, 1, 1.
- BENCS, L., SPOLNIK, Z., LIMPENS-NEILEN, D., SCHELLEN, H. L., JÜTTE, B. A. H. G. and VAN GRIEKEN, R. 2007. Comparison of hot-air and low-radiant pew heating systems on the distribution and transport of gaseous air pollutants in the mountain church of Rocca Pietore from artwork conservation points of view. *Journal of Cultural Heritage*, 8, 264-271.
- BERGSTEN, C.J., ODLYA, M., JAKIELA, S., SLATER, J., CAVICCHIOLI, A., de FARIA, D.L.A., NIKLASSON, A., SVENSSON, J-E., BRATASZ, L., CAMUFFO, D., della VALLE, A., BALDINI, F., FALCIAI, R., MENCAGLIA, A. and SENESI, F. 2010. Sensor system for detection of harmful environments for pipe organs (SENSORGANO). *e-Preservation Science* 7, 116-125.
- BERNARDI, A., BECHERINI, F., BASSATO, G., BELLIO, M., 2006. Condensation on ancient stained glass windows and efficiency of protective glazing system: two French case studies, Sainte-

- Chapelle (Paris) and Saint-Urbain Basilica (Troyes) *J Cult Heritage* 771.
- BERNARDI, A., BECHERINI, F., VERITÀ, M., AUSSET, P., BELLIO, M., BRINKMANN, U., CACHIER, H., CHABAS, A., DEUTSCH, F., ETCHEVERRY, M.-P., GEOTTI BIANCHINI, F., GODOI, R. H. M., KONTOZOVA-DEUTSCH, V., LEFÈVRE, R., LOMBARDO, T., MOTTNER, P., NICOLA, C., PALLOT-FROSSARD, I., RÖLLEKE, S., RÖMICH, H., SOMMARIVA, G., VALLOTTO, M. and VAN GRIEKEN, R. 2013. Conservation of stained glass windows with protective glazing: Main results from the European VIDRIO research programme. *Journal of Cultural Heritage*, 14, 527-536.
- BLOOMFIELD, D.P. and FISK, D.J. 1977. The optimisation of intermittent heating. *Building and Environment* 12 . 43-45.
- BORDASS, W. and BEMROSE, C. 1996. *Heating your Church*, London. Church House Publishing, London. p. 6, 7, 11, 12, 17, 18, 22, 25, 28, 42, 43, 64, 71.
- BRAUN, J. E. 2003. Load Control Using Building Thermal Mass. *Journal of Solar Energy Engineering*, 125, 292-300.
- BRIGGS, J.R., 1980. Environmental control for older buildings. Preprints, IIC Vienna Congress, 9-14.
- BRITISH STANDARDS INSTITUTE, 2012. PAS 198:2012. Specification for managing environmental conditions for cultural collections.
- BROSTROM, T. and LEIJONHUFVUD, G. 2008. Heat pumps for conservation heating. 8th Symposium on Building Physics in the Nordic Countries. Department of Civil Engineering, Technical University of Denmark.
- BUCHANAN, R. 1815. *A treatise on the economy of fuel, and management of heat, especially as it relates to heating and drying by means of steam*. Printed for the author.
- BUILDERS, T. I. O. B. O. 2003. Church heating and the Organ. In: BUILDING, T. I. O. B. O. (ed.). *Bury St. Edmunds: The Institute of British Organ Building*.
- BULLOCK, L. and BLADES, N. 2013. Comfort settings in historic rooms with collections. In: TRUST, N. (ed.) *Supplementary to the Manual of Housekeeping*. London.
- BURGESS, J. 2002. *Maintenance of a Masterpiece. St. Fin Barre's Cathedral, Cork*. Cork Region IEI/CIBSE. Rochestown Hotel, Cork.
- BYRNE, N. 2013. *The Thermo-Hygrometric Properties of Multi-Purpose Historic Buildings*. PhD, Trinity College Dublin.
- CAHILL, E. 2017. 'One of Dublin's largest Catholic churches to be demolished'. *Irish Times*, 3 February Available: <http://www.irishtimes.com/newspaper/ireland>. [Accessed 3 February 2017].
- CAMUFFO, D. 2014. *Microclimate for Cultural Heritage*, Amsterdam, Elsevier Science B.V. p. 4, 81, 89, 97, 100, 103, 226, 246, 331.
- CAMUFFO, D. and DELLA VALLE, A. 2007. *Church Heating: A balance between Conservation and Thermal comfort. Sustainable Climate Management Strategies*. Tenerife, Spain: The Getty Conservation Institute.
- CAMUFFO, D., PAGAN, E., RISSANEN, S., BRATASZ, L., KOZLOWSKI, R., CAMUFFO, M. and DELLA VALLE, A. 2010. An advanced church heating system favourable to artworks: A contribution to European standardisation. *Journal of Cultural Heritage*, 11, 205-219.
- CANADIAN COUNCIL OF ARCHIVES, 2003. *Basic Conservation of Archival Materials*. Revised Edition,

2003 Chapter 3: Environment. Canadian Council of Archives, Ottawa.

- CARVALHO, L. 2017. Impact of heating systems on three churches in Ireland. Internship report, Trinity College, Dublin.
- CATHOLIC DIRECTORY. Available: <http://www.thecatholicdirectory.com/directory.cfm>. [Accessed 4 July 2014].
- CENTRAL STATISTICS OFFICE, 2011. Census 2011, Available: <http://www.cso.ie/census>. [Accessed 14 May 2017].
- CHRIST CHURCH CATHEDRAL, 2017. Available: www.christchurchcathedral.ie/about/library-archive. [Accessed 14 March 2017].
- CHURCH OF ENGLAND, 2012-2013. Shrinking the Footprint Energy Audit Report 2012/13. In: SYMONDS, K. (ed.). London: Church of England.
- CHURCH OF ENGLAND, 2013. Inaugural sermon, Dr. Justin Welby. Archbishop of Canterbury. Canterbury. Available: <http://www.archbishopofcanterbury.org/articles.php/5038>. [Accessed 1 August 2017].
- CHURCH OF ENGLAND, 2017. Available: <https://www.churchofengland.org/about-us/our-buildings/cathedrals.aspx>. [Accessed 2 June 2017].
- CHURCH OF IRELAND. Available: <https://www.ireland.anglican.org/directory>. [Accessed 22 May 2014].
- CIBSE 2015. Guide A: Environmental Design. London: Chartered Institute of Building Services Engineers (CIBSE).
- CODE OF CANON LAW. 2003. Available: <http://www.vatican.va/archive/ENG1104/-INDEX.HTM>. [Accessed 21 December 2016].
- CONNOLLY, S.J. 1982. Priests and People in Pre-Famine Ireland 1780-1845. St. Martin's Press, New York. *Journal of Social History*. Spring 84. Vol.17. Issue3.
- CORCORAN, F. 2009. Controlling Temperature in the Vicinity of the Willis Organ in St. Patrick's Cathedral, Dublin. The University of Dublin, Trinity College.
- CRAGOE, C. D. 2008. How to read buildings, London: The Herbert Press. p.247.
- CRAWFORD, J. and GILLESPIE, R. 2009. St. Patrick's Cathedral, Dublin. A History, Dublin, Four Courts Press. p.2.
- DAVIS, N. 2006. Tracing the evolution of preservation environments in archives, museums, and libraries. 20th Annual Preservation Conference: Beyond the Numbers: Specifying and Achieving an Efficient Preservation Environment. National Archives, Washington, D.C. Available: <http://www.archives.gov/preservation/conferences/2006/presentations.html>. [Accessed 2 December 2016].
- DAY, J. G. and PATTON, H. E. 1932. The cathedrals of the Church of Ireland, Dublin, Society for the Promotion of Christian Knowledge (SPCK).
- de DEAR, R. J. 2011. Revisiting an old hypothesis of human thermal perception: alliesthesia. *Building Research & Information*, 39:2, 108-117.
- de DEAR, R. J., AKIMOTO, T., ARENS, E. A., BRAGER, G., CANDIDO, C., CHEONG, K. W. D., LI, B., NISHIHARA, N., SEKHAR, S. C., TANABE, S., TOFTUM, J., ZHANG, H. and ZHU, Y. 2013. *Progress*

- in thermal comfort research over the last twenty years. *Indoor Air*, 23, 442-461.
- de DEAR, R.J. and BRAGER, G.S. 2002. Thermal comfort in naturally ventilated buildings. Revisions to ASHRAE Standard 55. *Energy and Buildings* 34(6), 549-561.
- de SAULLES, T. 2005. Thermal Mass A concrete solution for a changing climate. The Concrete Centre. Camberley.
- de SAULES, T. 2009. Thermal mass explained. The Concrete Centre. Camberley. Available: www.concretecentre.com. [Accessed 14 August 2016].
- DEPARTMENT OF COMMUNICATIONS, CLIMATE ACTION AND ENVIRONMENT (DCCAE), 2014. Available: www.dccae.gov.ie/en-ie/climateaction/publications/.../National-Policy-Position.aspx. [Accessed 15 September 2017].
- DEPARTMENT OF COMMUNICATIONS, CLIMATE ACTION AND ENVIRONMENT (DCCAE), 2015. Available: dccae.gov.ie/en-ie/climate-action/legislation/Pages/Climate-Action-and-Low-carbon-Development-Act-2015.aspx. [Accessed 16 September 2017].
- DILI, A. S., NASEER, M. A. and VARGHESE, T. Z. 2010. Thermal comfort study of Kerala traditional residential buildings based on questionnaire survey among occupants of traditional and modern buildings. *Energy and Buildings*, 42, 2139-2150.
- DJONGYANG, N., TCHINDA, R. and NJOMO, D. 2010. Thermal comfort: A review paper. *Renewable and Sustainable Energy Reviews*, 2626-2640.
- DOEHLG 2011. Building Regulations Part L. Conservation of Fuel and Energy-Buildings other than Dwellings. Dublin: Department of the Environment, Heritage and Local Government (DoEHLG).
- DUNCAN, T. and FLEMING, W. E. C. St. Patrick's Cathedral Armagh (Church of Ireland), Armagh, St. Patrick's Cathedral.
- ENGINEERING TOOLBOX. Available: www.engineeringtoolbox.com. [Accessed 6 June 2017].
- ENGLISH HERITAGE. 2008. Available: <https://historicengland.org.uk/advice/constructive-conservation/conservation-principles/> Conservation Principles. [Accessed 5 May 2016].
- EPSTEIN, Y. and MORAN, D. S. 2006. Thermal Comfort and the Heat Stress Indices. *Industrial Health* 2006, 44, 388-396.
- EUROPEAN COMMISSION, 2002. Available: <http://ec.europa.eu/energy/en/topics/energy-efficiency/buildings>. [Accessed 3 June 2016].
- EUROPEAN SOCIAL SURVEY, 2016. Available: www.europeansocialsurvey.org/. [Accessed 1 March 2017].
- FANGER, P. O. 1970. Thermal Comfort. Danish Technical Press.
- FEILDEN, B. M. 2003. Conservation of Historic Buildings, Oxford, Architectural Press. p. 96, 135, 136, 177.
- FORSYTH, M. 2007. Understanding Historic Building Conservation, Oxford, Blackwell Publishing.
- GALLOWAY, P. 1992. The Cathedrals of Ireland, Belfast: The Institute of Irish Studies, The Queen's University of Belfast. p. XV, 13, 120, 129, 157, 221.
- GATES, J., and O'HARE, J. 2003. St. Patrick's cathedral, Armagh. Belfast: Octoberstore Design. p. 30.

- GOOGLE MAPS 2014. Map of English cathedrals. Available: <http://maps.google.com>. [Accessed 2 February 2017.]
- GOOGLE MAPS 2014. Map of Ireland. Available: <http://maps.google.ie>. [Accessed 14 March 2015].
- GOTO, T., and TOFTUM, J., DE DEAR, R. and FANGER, P. O. 2002. Thermal sensation and comfort with transient metabolic rates. 9th International Conference on Indoor Air Quality and Climate. Monterey, CA: Santa Cruz, CA: Indoor Air.
- HA, E. and Van Hoof, J., 2012. The adaptive approach to thermal comfort: A critical overview. *Energy and Buildings*, 51.101-110.
- HEALY, C. 2006. Saint Fin Barre's cathedral. *The Making of a Masterpiece*. Dublin.
- HENSEN, J. L. M. 1991. On the thermal interaction of building structure and heating and ventilation system. Technische Universiteit Eindhoven.
- HISLOP, M. 2012. *How to build a cathedral*, London, Bloomsbury Publishing Plc. p 6.
- HOLMES-INSULATION .2012. Available: <http://www.holme-insulation.ie/index.php?page=Why-insulate> [Online]. [Accessed 19 August 2017].
- HSE. 2014. Available: <http://www.hse.gov.uk/temperature/thermal/explained.htm> [Accessed 12 March 2015].
- I.S. EN ISO 7730:2005. Ergonomics of the thermal environment. Analytical determination and interpretation of thermal comfort using calculation of the PMV and PPD indices and local thermal comfort criteria. Dublin: National Standards Authority of Ireland.
- IBO 2003. Church heating and the organ. In: BUILDING, T. I. O. B. O. (ed.) First ed. Northwood, Middlesex.: IBO.
- ICOMOS-ICTC. Available: www.icomos-ictc.org. [Accessed 22 March 2017].
- INCROPERA, F. P. and DEWITT, D. P. 1996. *Introduction to Heat Transfer*. U.S.A., John Wiley & Sons Inc. 3rd. edition. p 2, 3 ,8, 446.
- INSTITUTE OF CONSERVATION 2011. Available: www.conservationregister.com/Plcon-carestainedglass.asp. [Accessed 1 August 2017].
- INSTITUTE OF CONSERVATION, 2011. Conservation Register, Available: www.conservationregister.com. [Accessed 23 May 2017].
- IRISH INDEPENDENT. 2017. 'Priest shortage will mean end of regular weekend Masses'. - Bishop. [online] Available: <http://www.independent.ie/irish-news/priest-shortage-will-mean-end-of-regular-weekend-masses-bishop-35887774.html> [Accessed: 12 July 2017].
- IRISH TIMES, 2017. Available: <http://www.irishtimes.com/opinion/five-centuries-after-the-reformation-martin-luther-s-legacy-lives-on-1.2965674>. [Accessed 26 August 2017].
- IRISH TIMES. 2016. 'Mass attendance in Dublin to drop by one-third by 2030'. *The Irish Times*. [online] Available: <https://www.irishtimes.com/news/social-affairs/religion-and-beliefs/mass-attendance-in-dublin-to-drop-by-one-third-by-2030-1.2504351> [Accessed 4 April 2016].
- IS EN 15026: 2007. Hygrothermal performance of building components and building elements: Assessment of moisture transfer by numerical simulation. Dublin: National Standards Authority of Ireland.

- IS EN 15757: 2010. Conservation of cultural property. Specifications for temperature and relative humidity to limit climate-induced mechanical damage in organic hygroscopic materials. Dublin: National Standards Authority of Ireland.
- IS EN 15759-1: 2012. (English): Conservation of cultural property - Indoor climate - Part 1: Guidelines for heating churches, chapels and other places of worship. Dublin: National Standards Authority of Ireland.
- IS EN 2012. PAS 198:2012, Specifications for managing environmental conditions for cultural collections. Dublin: National Standards Authority of Ireland..
- IS EN 2013. PAS 7913:2013. Guide to the conservation of historic buildings. Dublin: National Standards Authority of Ireland.
- ISO 10456: 2007: Building materials and products - Hygrothermal properties - Tabulated design values and procedures for determining declared and design thermal values. Geneva, Switzerland. ISO, 2007.
- ISO 13788: 2012: Hygrothermal performance of building components and building elements: Internal surface temperature to avoid critical surface humidity and interstitial condensation: Calculation methods. Geneva, Switzerland: ISO, 2013.
- ISSP, 2012. ISSP Research Group (2012): International Social Survey Program: Religion III - ISSP 2008. GESIS Data Archive, Cologne. ZA4950 Data file Version 2.2.0, doi:10.4232/1.11334
- KALININA, A. 2013. Thermal and Humidity Behaviour in Ecclesiastical Buildings. MSc, Trinity College Dublin.
- KARLSSON, J., WADSO, L. and OBERG, M. 2013. A conceptual model that stimulates the influence of thermal inertia in building structures. *Energy and Buildings*, 60, 146-151.
- KENNEDY, B. 1999. Heat Transfer, Principles and Application. In: UNIVERSITY, T. O. (ed.) Dutton, J ed. Milton Keynes: The Open University.
- KILFENORA, Co. Clare 2017. Available: <https://www.kilfenoraclare.com/> [Accessed 15 June 2017].
- KINSELLA, S. 2009. An Architectural History of Christ Church cathedral Dublin c.1540-c.1870. D. Phil., Trinity College Dublin.
- LEAMAN , A.J., and BORDASS, W.T. 1997. Productivity in Buildings: the Killer variables. Workplace Comfort Forum, London, UK.
- LITTLE, J., FERRARO, C. and ARREGI, B. 2015. Insulating History - Hygrothermal Assessment of Insulation Retrofits in Historic Heavy Masonry Buildings. 2015 ASHRAE Annual Conference. Atlanta, USA: ProQuest.
- LODI, C., MAGLI, S., CONTINI, F. M., MUSCIO, A. and TARTARINI, P. 2017. Improvement of thermal comfort and energy efficiency in historical and monumental buildings by means of localised heating based on non-invasive electric radiant panels. *Applied Thermal Engineering*. (Unpublished).
- MAKRODIMITRI M., PAPAVALIIOU S., CAMPBELL W. and STEEMERS K. 2012. Heating historic structures. A review of heating systems in historic church buildings and implications related to conservation and comfort. The case of four historic churches in Cambridge. In: UNIVERSITY, C. (ed.). Cambridge: Department of Architecture.
- MAKRODIMITRI, M., CAMPBELL, J. W. P. and STEEMERS, K. 2011. Sustainability and heritage

conservation: Assessment of environmental performance and energy management for historic churches. 3rd International Conference on Sustainability in Energy and Buildings, SEB` 11. Marseilles, France: Springer.

- MARTINEZ-MOLINA, A., TORT-AUSINA, I., CHO, S. and VIVANCOS, J. 2016. Energy efficiency and thermal comfort in historic buildings: A review. *Renewable and Sustainable Energy Reviews*, 61, 70-85.
- MATTHEWS, H. D. and CALDEIRA, K. 2008. Stabilising climate requires near-zero emissions. *Geophysical Research Letters*, 35, 5.
- MCMULLAN, R. 2007. *Environmental Science in Building*. New York. Palgrave Macmillan. P.14, 48, 50-51, 87-88, 292, 322-324.
- METHODIST CHURCH. Available: <https://www.irishmethodist.org/>. [Accessed 25 May 2014].
- MICHALSKI, S. 1998. Climate Control Priorities and Solutions for Collections in Historic Buildings. *Historic Preservation Forum* 12(4): 8-14.
- MICHALSKI, S. 2000. Guidelines for Humidity and Temperature in Canadian Archives. Technical Bulletin No. 23. Canadian Conservation Institute, Ottawa.
- MILLS, E.D. 1959. *The Modern Church*. Architectural Press, Princetown.
- MILNE, K. 2000. *Christ Church Cathedral. A history*, Dublin, Four Courts Press.
- NEUHAUS, E. and SCHELLEN, H. L. 2007. Conservation Heating for a Museum Environment in a Monumental Building. In: ASHRAE (ed.). Eindhoven.
- NEWSHAM, G. 1992. Occupant Movement and thermal modelling of buildings. *Energy and Buildings*, 18, 57-64.
- NIALL, D. 2015. Thermal mass behaviour of concrete panels incorporating phase change materials. MSc, Trinity College Dublin.
- NICOL, F., HUMPHREYS, M. & ROAF, S. 2012. *Adaptive Thermal Comfort*, Oxford, Routledge.
- NICOL, J.F. and HUMPHREYS, M.A. (2002). Adaptive thermal comfort and sustainable thermal standards for buildings. *Energy and Buildings*, 34(6), 563-572.
- NORTHERN IRELAND STATISTICS AND RESEARCH AGENCY, 2011. Available: <https://www.nisra.gov.uk/statistics/2011-census/results>. [Accessed 16 August 2017].
- O'GRADA, C. 2015. Famine in Ireland, 1300-1900. Available: <https://ssrn.com/abstract> or <http://dx.doi.org/10.2139>. [Accessed 13 November 2016].
- O'KEEFE, T. 2015. *Medieval Irish Buildings*, Dublin, Four Courts Press. p 142.
- OROSA, J. A. 2009. Research on the Origins of thermal Comfort. *European Journal of Scientific Research*, 34, 561-567.
- OROSA, J. A. and OLIVEIRA, A. C. 2011. A new thermal comfort approach comparing adaptive and PMV models. *Renewable Energy*, 36, 951-956.
- OSELAND, N. A. 1995. Predicted and reported thermal sensation in climate chambers, offices and homes. *Energy and Buildings*, 23, 105-115.
- PAPAVASILEIOU, S., MAKRODIMITRI, M., CAMPBELL, J.W.P., K. STEEMERS, K., "The Construction and Integration of Heating Systems in Churches in the United Kingdom from the 17 th to the Early

- 20th century" Carvais, R., Guillerme, A., Negre, V., & Sakarovitch, J.,(Eds.), Nuts and Bolts of Construction History, (Paris: Picard, 2012) 3 vols., vol. 3, pp.277-287
- PILIO GROUP, 2017. Available: www.piliogroup.com. [Accessed 15 May 2016].
- PRESBYTERIAN CHURCH. Available: <https://www.presbyterianireland.org>. [Accessed 24 April 2014].
- REILLY, A. and KINNANE, O. 2016. The Impact of Thermal Mass on Building Energy Consumption. Belfast: The Queen's University.
- ROBERTS, B. and FERRIS, F. J. 2006. The Warming & Ventilation of Victorian and Edwardian Churches. Chartered Institute of Building Services Engineers. CIBSE.
- RODWELL, W. 2012. The archaeology of churches, Gloucestershire, Amberley Publishing.
- ROHAN, P. K. 1975. The Climate of Ireland. Dublin: Government Stationary Office.
- ROJAS, E. 2014. Historic cities and the Venice Charter. Change over Time, 6.2.
- SAMEK, L., DE MAEYER-WOROBIEC, A., SPOLNIK, Z., BENCS, L., KONTOZOVA, V., BRATASZ, Ł., KOZŁOWSKI, R. and VAN GRIEKEN, R. 2007. The impact of electric overhead radiant heating on the indoor environment of historic churches. Journal of Cultural Heritage, 8, 361-369.
- SHELLEN, H. L., VAN SCHIJNDEL, A. W. M., NEILEN, D. and VAN ARLR, M. A. P. 2003. Damage to a monumental organ due to wood deformation caused by church heating. PhD, Eindhoven University of Technology.
- SILVA, H. E. AND HENRIQUES, M. A. 2016. Preventative conservation of historic buildings in temperate climates. The importance of a risk-based analysis on the decision-making process. Energy and Buildings, 107, pp26-36.
- SMITH, B. J., GOMEZ-HERAS, M. and McCABE, S. 2008. Understanding the decay of stone-built cultural heritage. Progress in Physical geography, 32, 439-461.
- ST. PATRICKS CATHEDRAL, DUBLIN. Available: www.stpatrickscathedral.ie. [Accessed, 12 July 2017].
- STULL, R. B. 2000. Meteorology for Scientists and Engineers. Pacific Grove. C.A. USA. Brooks/Cole.
- SUSTAINABILITY WORKSHOP. Available: www.sustainabilityworkshop.autodesk.com [Accessed 2 August 2017].
- TAMURA, Y and Yoshie, R. 2016. Advanced Environmental Wind Engineering. Japan. Springer Japan.
- THOMPSON, G. 1994. The museum environment (conservation and museology), 2nd ed. Butterworth-Heinemann, Oxford, U.K.
- TREGOLD, T., 1824. Principles of Warming and Ventilating Public Buildings, Dwelling Houses..., &c.;... with illustrations, etc. Josiah Taylor.
- UNESCO. 2012. Tangable Cultural Heritage (Online). Cairo: United Nations Educational, Scientific and Cultural Organisation (UNESCO). Available: <http://www.unesco.org/new/en/cairo/cultural/tangible-cultural>. [Accessed 2 February 2017].
- UNITED KINGDOM GOVERNMENT, 2008. Available: www.legislation.gov.uk. [Accessed 2 May 2017].
- UNITED NATIONS FRAMEWORK CONVENTION ON CLIMATE CHANGE, 1997. Available: www.unfccc.int/kyoto_protocol/items/2830.php. [Accessed 19 March 2016].
- UNIVERSITY OF MASSACHUSETTS, BOSTON. 2014. Available:

<http://www.umb.edu/news/detail/keynotespeaker>. [Accessed 2 August 2017].

- VAN HOOFF, J. 2008. Forty years of Fanger's model of thermal comfort: comfort for all. *Indoor Air*, 18, 182-201.
- VAN SCHIJNDEL, A. W. M., SCHELLEN, H. L. and DE WIT, M. H. 2009. Improved HVAC operation to preserve a church organ. *Building and Environment*, 44, 156-168.
- VARAS-MURIEL, M. J., MARTÍNEZ-GARRIDO, M. I. and FORT, R. 2014. Monitoring the thermal-hygrometric conditions induced by traditional heating systems in a historic Spanish church (12th–16th C). *Energy and Buildings*, 75, 119-132.
- VATICAN. Available: http://www.vatican.va/archive/ENG1104/_INDEX.HTM. [Accessed 20 July 2017].
- WALSH, R., KENNY, P. and BROPHY, V. 2006. Thermal mass and sustainable building. In: FEDERATION, I. C. (ed.). Dublin: University College Dublin, Energy Research Group.
- WHIFFEN, T. R., and S. B. RIFFAT. "A review of PCM technology for thermal energy storage in the built environment: Part I." *International Journal of Low-Carbon Technologies* 8.3 (2012): 147-158.
- YAU, Y. and CHEW, B. 2014. A review on predicted mean vote and adaptive thermal comfort models. *Building Services Engineering Research and Technology*, 35, 23-35.
- ZENG, R., WANG, X., DI, H., JIANG, F. and ZHANG, Y. 2011. New concepts and approach for developing energy efficient buildings: ideal specific heat for building internal thermal mass. *Energy and Buildings*, 43, 1081-1090.

Bibliography for Cathedrals in Ireland

- ARCHDIOCESE OF ARMAGH. 2014. St. Patrick's Cathedral Armagh [Online]. Available: www.armagharchdiocese.org [Accessed 1 August 2014].
- ARMAGH CATHEDRAL. 2014. St. Patrick's Cathedral Armagh [Online]. Available: www.stpatricks-cathedral.org [Accessed 4 August 2014].
- BELFAST CATHEDRAL. 2014. St. Ann's Cathedral Belfast [Online]. Available: www.belfastcathedral.org [Accessed 1 August 2014].
- CARLOW CATHEDRAL. 2014. Cathedral of the Assumption [Online]. Available: www.carlowcathedral.ie [Accessed 2 August 2014].
- CATHOLIC DIRECTORY. 2014. Ballaghaderren Cathedral [Online]. Available: www.thecatholicdirectory.com [Accessed 7 August 2014].
- CAVAN PARISH. 2014. Cavan Cathedral [Online]. Available: www.cavanparish.com [Accessed 7 August 2014].
- CHRIST CHURCH CATHEDRAL. 2014. Christ Church Cathedral Dublin [Online]. Available: www.christchurchdublin.ie [Accessed 6 August 2014].
- CHURCH OF IRELAND CLAIRE. 2014. St. Fachtnan's Cathedral Kilfenora [Online]. Available: www.churchofirelandclaire.com [Accessed 12 August 2014].
- CHURCH OF IRELAND. 2014. Kildare Cathedral [Online]. Available: www.meath.anglican.org/information/103 [Accessed 11 August 2014].
- CHURCH OF IRELAND. 2014. Trim Cathedral [Online]. Available:

- www.meath.anglican.org/information/103 [Accessed 19 August 2014].
- CLOYNE DIOCESE. 2014. Cobh Cathedral [Online]. Available: www.cloynedioocese.ie [Accessed 15 August 2014].
- CLOYNE UNION. 2014. Cloyne Cathedral [Online]. Available: www.cathedral.cloyne.anglican.org [Accessed 14 August 2014].
- CORK CATHEDRAL. 2014. Cathedral of St. Mary & St. Anne [Online]. Available: www.corkandross.org [Accessed 21 August 2014].
- CORK CATHEDRAL. 2014. St. Fin Barre's [Online]. Available: www.cathedral@cork.anglican.org [Accessed 22 August 2014].
- DERRY DIOCESE. 2014. St. Eugene's Cathedral [Online]. Available: www.steugenescathedral.com [Accessed 1 September 2014].
- DIOCESE OF CASHEL FERNS AND OSSORY. 2014. Cashel Cathedral, St. John the Baptist and St. Patrick's Rock [Online]. Available: www.tuam.anglican.org [Accessed 27 August 2014].
- DIOCESE OF CASHEL FERNS AND OSSORY. 2014. Christ Church Cathedral Waterford [Online]. Available: www.cashel.anglican.org [Accessed 25 August 2014].
- DIOCESE OF CASHEL FERNS AND OSSORY. 2014. Ferns Cathedral, St. Edan's Cathedral [Online]. Available: www.cashel.anglican.org [Accessed 29 August 2014].
- DIOCESE OF CASHEL FERNS AND OSSORY. 2014. Kilkenny Cathedral, St. Canice's Cathedral [Online]. Available: www.cashel.anglican.org [Accessed 28 August 2014].
- DIOCESE OF CASHEL FERNS AND OSSORY. 2014. Leighlin Cathedral, St. Laserian's Cathedral [Online]. Available: www.cashel.anglican.org [Accessed 15 August 2014].
- DIOCESE OF CASHEL FERNS AND OSSORY. 2014. Lismore cathedral, St. Carthage's Cathedral [Online]. Available: www.cashel.anglican.org [Accessed 1 August 2014].
- DIOCESE OF CLOGHER. 2014. Clogher Cathedral St. Macartan's [Online]. Available: www.clogher.anglican.org [Accessed 1 August 2014].
- DIOCESE OF CLOGHER. 2014. Enniskillen Cathedral St. Macartan's [Online]. Available: www.clogher.anglican.org [Accessed 4 August 2014].
- DIOCESE OF CORK AND ROSS. 2014. St. Patrick's Cathedral Skibereen [Online]. Available: www.corkandross.org [Accessed 17 August 2014].
- DIOCESE OF DERRY AND RAPHOE. 2014. Raphoe Cathedral St. Ennan's [Online]. Available: www.derryandraphoe.org [Accessed 17 August 2014].
- DIOCESE OF DOWN & CONNOR. 2014. St. Peter's Cathedral, Belfast [Online]. Available: www.stpeterscathedralbelfast.com [Accessed 14 September 2014].
- DIOCESE OF KILMORE ELPHIN AND ARDAGH. 2014. Kilmore Cathedral St. Fethlimidh's [Online]. Available: www.ireland.anglican.org/information/98 [Accessed 14 August 2014].
- DIOCESE OF LIMERICK. 2014. St. John's Cathedral Limerick [Online]. Available: www.limerickdiocese.org [Accessed 1 September 2014].
- DIOCESE OF RAPHOE. 2014. Cathedral of St. Eunan & St. Columba Letterkenny [Online]. Available: www.raphoediocese.ie/bishop/cathedrl [Accessed 28 August 2014].

DIOCESE OF TUAM KILLALA AND ACHONRY. 2014. Killala St. Patrick's Cathedral [Online]. Available: www.tuam.anglican.org [Accessed 19 August 2014].

DIOCESE OF TUAM KILLALA AND ACHONRY. 2014. St. Crumanthy's Cathedral Achonry [Online]. Available: www.tuam.anglican.org/parishes/ballina-parish/saint-crumanthy-cathedral-achonry/ [Accessed 3 August 2014].

DIOCESE OF TUAM KILLALA AND ACHONRY. 2014. St. Mary's Cathederal Tuam [Online]. Available: www.tuam.anglican.org [Accessed 21 August 2014].

DOWN CATHEDRAL. 2014. Downpatrick Cathedral Holy and Undivided Trinity [Online]. Available: www.downcathedral.org [Accessed 15 September 2014].

DROMORE CATHEDRAL. 2014. The Cathedral Church of Christ the Redeemer [Online]. Available: www.cathedral.dromore.anglican.org [Accessed 1 August 2014].

ENNIS PARISH. 2014. Ennis Cathedral [Online]. Available: www.ennisparish.com [Accessed 15 August 2014].

ENNISCORTHY CATHEDRAL. 2014. St. Aidan's cathedral [Online]. Available: www.staidanscathedral.ie [Accessed 24 August 2014].

GALWAY CATHEDRAL. 2014. Cathedral of our Lady Assumed into Heaven & St. Nicholas [Online]. Available: www.galwaycathedral.ie [Accessed 14 October 2014].

GALWAY CATHEDRAL. 2014. Cathedral of the Assumption of the Blessed Virgin Mary [Online]. Available: www.gcatholic.org/churches/europe/2157.htm [Accessed 4 October 2014].

IRELAND, C. O. 2014. Church of Ireland [Online]. Dublin. [Accessed 29 July 2014].

KILLARNEY CATHEDRAL. 2014. St. Mary's Cathedral [Online]. Available: www.dioceseofkerry.ie [Accessed 1 September 2014].

KILLKENNY CATHEDRAL. 2014. St. Mary's Cathedral [Online]. Available: www.stmaryscathedral.ie [Accessed 1 September 2014].

LONDONDERRY CATHEDRAL. 2014. St. Columb's Cathedral [Online]. Available: www.stcolumbscathedral.org [Accessed 31 July 2014].

LONGFORD PARISH. 2014. St. Mel's Cathedral [Online]. Available: www.longfordparish.com [Accessed 3 March 2014].

LOUGHREA CATHEDRAL. 2014. St. Brendan's Cathedral [Online]. Available: www.loughreacathedral.ie [Accessed 14 February 2014].

MONAGHAN CATHEDRAL. 2014. St. Macartan's Cathedral [Online]. Available: www.monaghan-rackwallace.ie/parish-churches/cathedral [Accessed 14 August 2014].

MULLINGAR CATHEDRAL. 2014. Christ The King Cathedral [Online]. Available: www.mullingarparish.com [Accessed 14 April 2014].

NEWRY CATHEDRAL. 2014. Cathedral of St. Patrick & St. Coleman [Online]. Available: www.newrycathedralparish.org [Accessed 17 May 2014].

PARISH OF KILMOREMOY. 2014. Ballina Cathedral St. Muredach's [Online]. Available: www.ballinaparish.org [Accessed 1 June 2014].

PARISHES, R. U. O. 2014. Rosscarbery Cathedral St. Fachtna [online]. Available at

- www.rosscarrberry.ie/ross/ [Accessed 30 June 2014].
- PRO CATHEDRAL DUBLIN. 2014. Pro Cathedral Dublin [Online]. Available: www.procathedral.ie [Accessed 14 July 2014].
- SLIGO CATHEDRAL GROUP. 2014. Cathedral Church of St. Mary the Virgin and St. John the Baptist Sligo [Online]. Available: www.sligocathedral@elphin.anglican.org [Accessed 17 August 2014].
- SLIGO CATHEDRAL. 2014. Cathedral of the Immaculate Conception [Online]. Available: www.sligocathedral.ie [Accessed 17 June 2014].
- ST. PATRICK'S CATHEDRAL. 2014. St. Patrick's Cathedral Dublin [Online]. Available: www.stpatricks-cathedral.org [Accessed 22 August 2014].
- THURLES PARISH. 2014. Cathedral of the Assumption Thurles [Online]. Available: www.thurlesparish.ie [Accessed 29 August 2014].
- TUAM PARISH. 2014. Tuam Cathedral, Cathedral of the Assumption [Online]. Available: www.tuamparish.org [Accessed 1 September 2014].
- UNITED DIOCESE OF LIMERICK AND KILLALOE. 2014. Clonfert Cathedral St. Brendan's [Online]. Available: www.limerick.anglican.org/parish [Accessed 14 May 2014].
- UNITED DIOCESE OF LIMERICK AND KILLALOE. 2014. Limerick Cathedral St. Mary's [Online]. Available: www.limerick.anglican.org [Accessed 18 August 2014].
- UNITED DIOCESE OF LIMERICK AND KILLALOE. 2014. Killaloe Cathedral [Online]. Available: www.killaloe.anglican.org [Accessed 17 September 2014].
- WATERFORD CATHEDRAL. 2014. Cathedral of the Most Holy Trinity [Online]. Available: www.watford-cathedral.com [Accessed 1 June 2014].

APPENDICES

Table A.1 - Summary of Appendices of all monitored cathedrals

Number	City		Cathedral
1 A	Armagh	RC	St. Patrick's Cathedral - SUMMER
1 B		RC	St. Patrick's Cathedral - WINTER
2		Col	St. Patrick's Cathedral
3	Belfast	Col	St. Anne's Cathedral
4		RC	St. Peter's Cathedral
5	Carlow	RC	Cath. of the Assumption
6	Cork	Col	St. Fin Barre's
7		RC	St. Mary & St. Anne Cathedral
8	Derry	Col	St. Columb's
9 A	Dublin	Col	Christ Church Cathedral (CCC) – SUMMER
9 B		Col	Christ Church Cathedral (CCC) - WINTER
10		Col	St. Patrick's
11		RC	Pro Cathedral
12	Enniskillen	Col	St. Macartin's
13	Galway	RC	St. Nicholas
14	Kildare	Col	St. Brigid
15 A	Kilkenny	Col	St. Canice's Cathedral– SUMMER
15 B		Col	St. Canice's Cathedral- WINTER
16		RC	St. Mary's
17	Killaloe	Col	St. Flannan's
18	Killarney	RC	St. Mary's
19	Limerick	Col	St. Mary's
20	Lismore	Col	St. Carthage's
21	Longford	RC	St. Mel's
22	Loughrea	RC	St Brendan's Cathedral
23	Old Leighlin	Col	St. Laesarian's Cathedral
24	Raphoe	Col	St. Eunan's Cathedral
25	Skiberreen	RC	St. Patrick's Cathedral

Appendix 1 – St. Patrick’s Church of Ireland Cathedral



Dublin Image: Patrick Cavanagh



Picture Taken by Rafaesmar. (Creative Commons license 4.0)

Name: The National Cathedral and Collegiate Church of St. Patrick

Location: Dublin City, Republic of Ireland

Tradition: Church of Ireland

Outline history: St. Patrick’s cathedral is, according to the cathedral web site, Ireland’s tallest church and largest cathedral. There has been a church on the site since circa 450 when St. Patrick, about whose life little is known, is reputed to have baptized his followers in a well on the site. The church was rebuilt by the Normans and dedicated in 1221. This led to much conflict between the lay canons of St. Patrick’s which was outside the city walls and the Augustinian canons of Christ Church cathedral which was inside the city walls. Since there cannot be two cathedrals in one diocese St. Patrick’s was given honorary title of the National Cathedral of the Church of Ireland. The cathedral has been extensively remodeled over the centuries with probably the greatest changes being made between the years 1860-65, when the building was extensively renovated as a result of the generosity of the Guinness brewing family. The most famous dean of the cathedral was Dean Jonathan Swift who wrote *Gulliver’s Travels*. The cathedral has both a choir school (Ireland’s oldest school founded in 1432) and a grammar school. The cathedral contains many fine monuments, stained glass and items of great historic interest. St. Patrick’s has been the location for many important civic, cultural and religious events. This is a cruciform building with side aisles and chapels. The floor is tiled and the roof stone with a void between the ceiling and the roof. The windows are single glazed with storm glazing and there are many wooden fittings including the pews and choir. The cathedral has a fine pipe organ and many stone monuments.

All references in this section, unless otherwise stated, are from Galloway, 1992.

Appendix 1.1 – Floor plan with loggers and TinyTag location

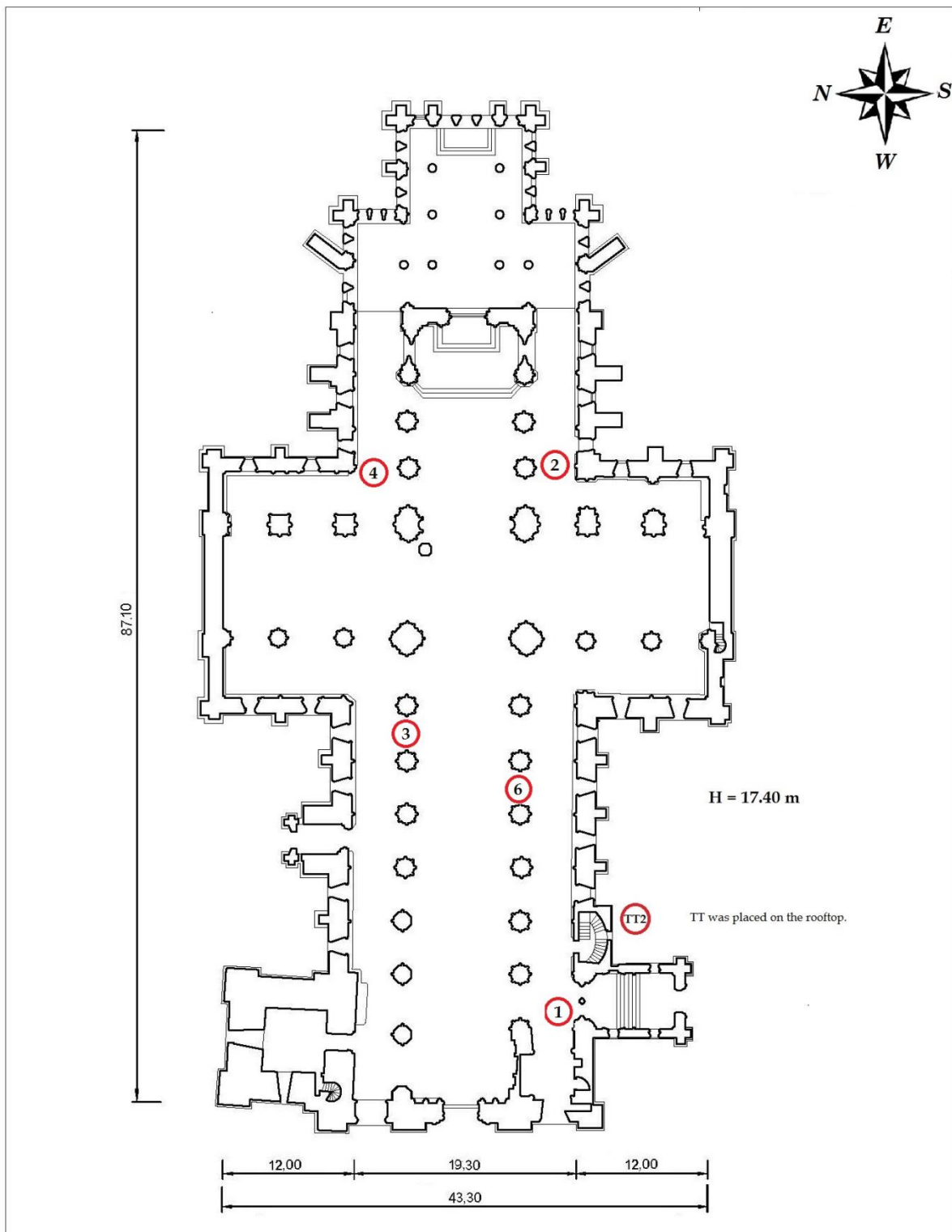

St. Patrick's Cathedral Dublin - Ireland Church of Ireland	Size:	24,000 m ³
	Location:	53° 20' 22' N / 6° 16' 17' W
	Heating type:	LPHW

Appendix 1.2 – Loggers' graphs

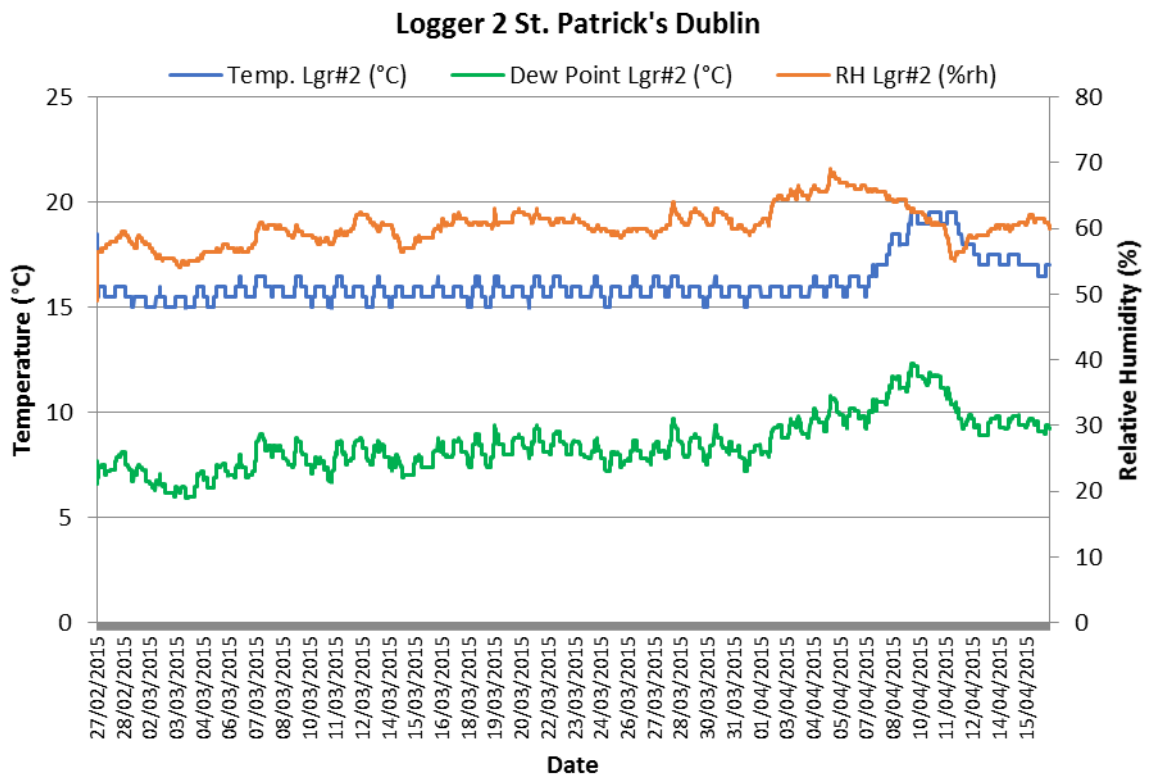
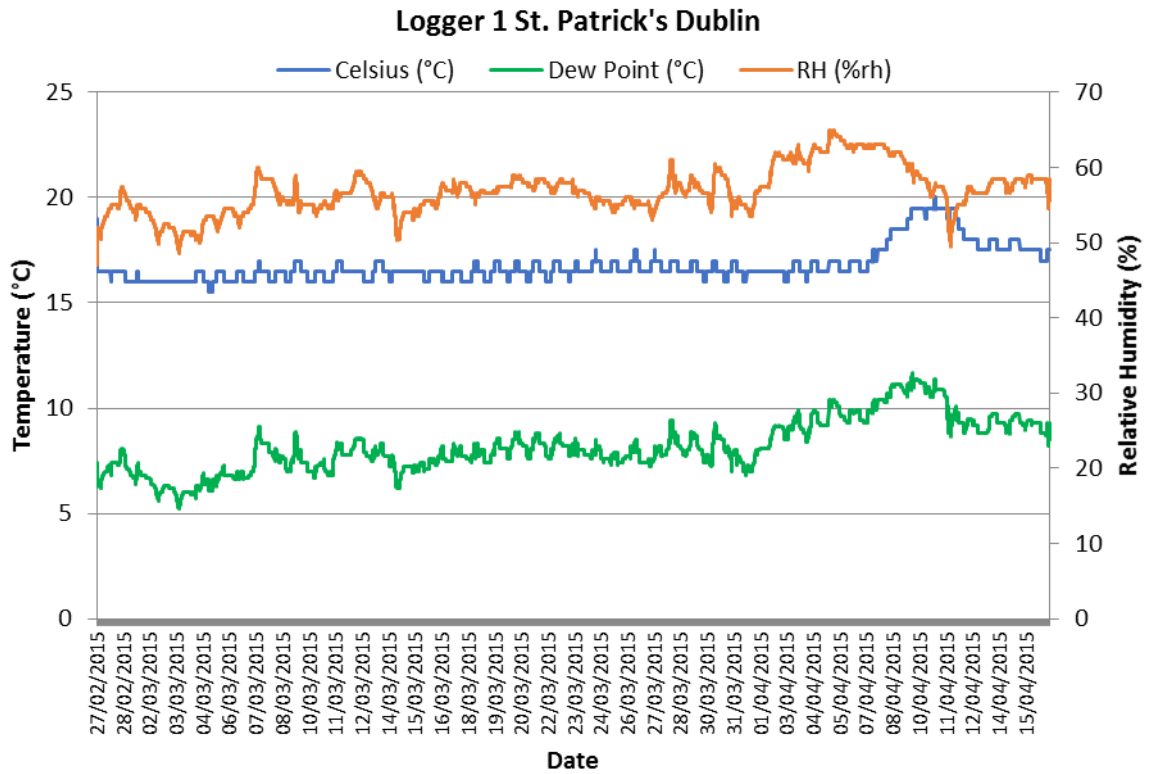

Logger 3 St. Patrick's Dublin

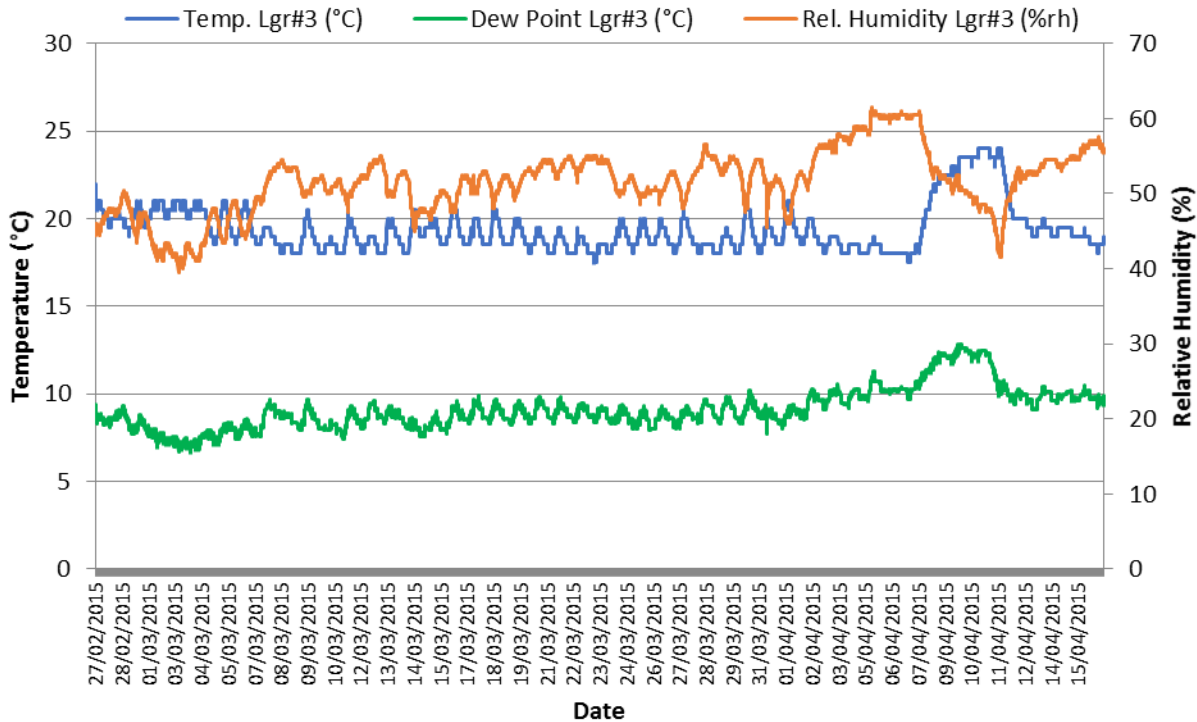

Logger 4 St. Patrick's Dublin

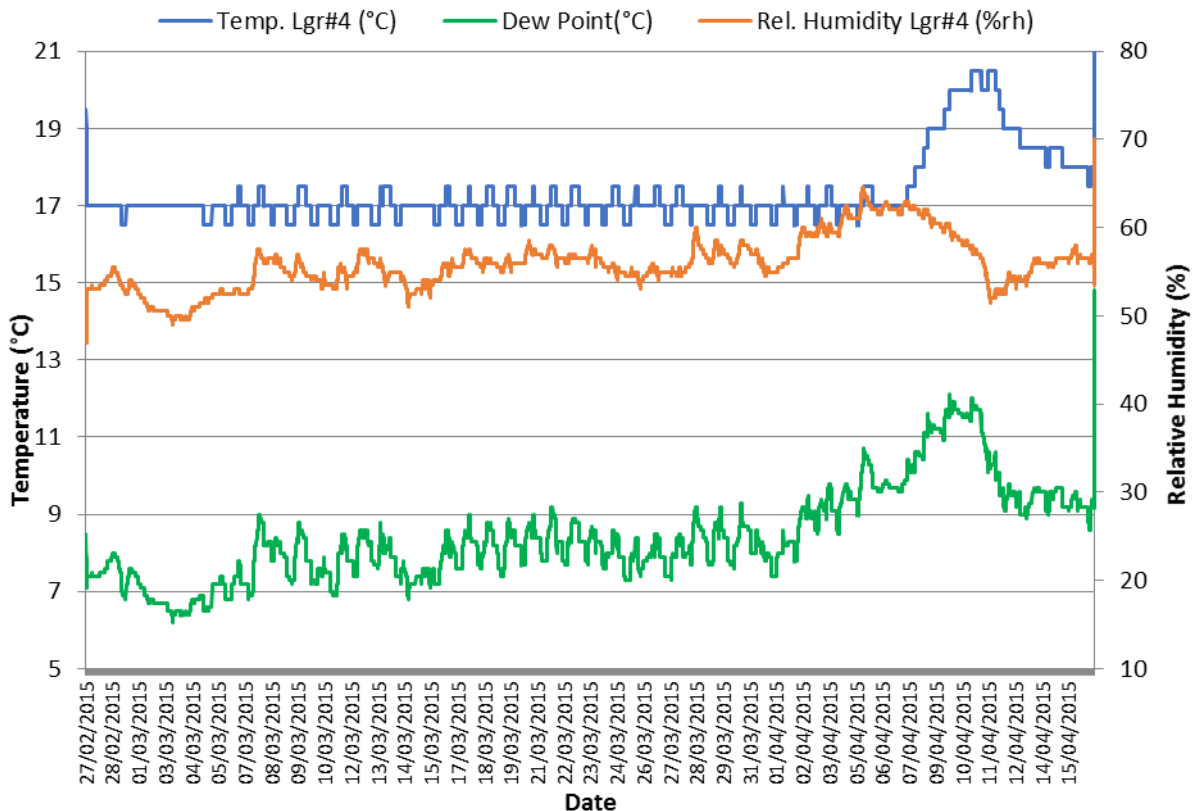

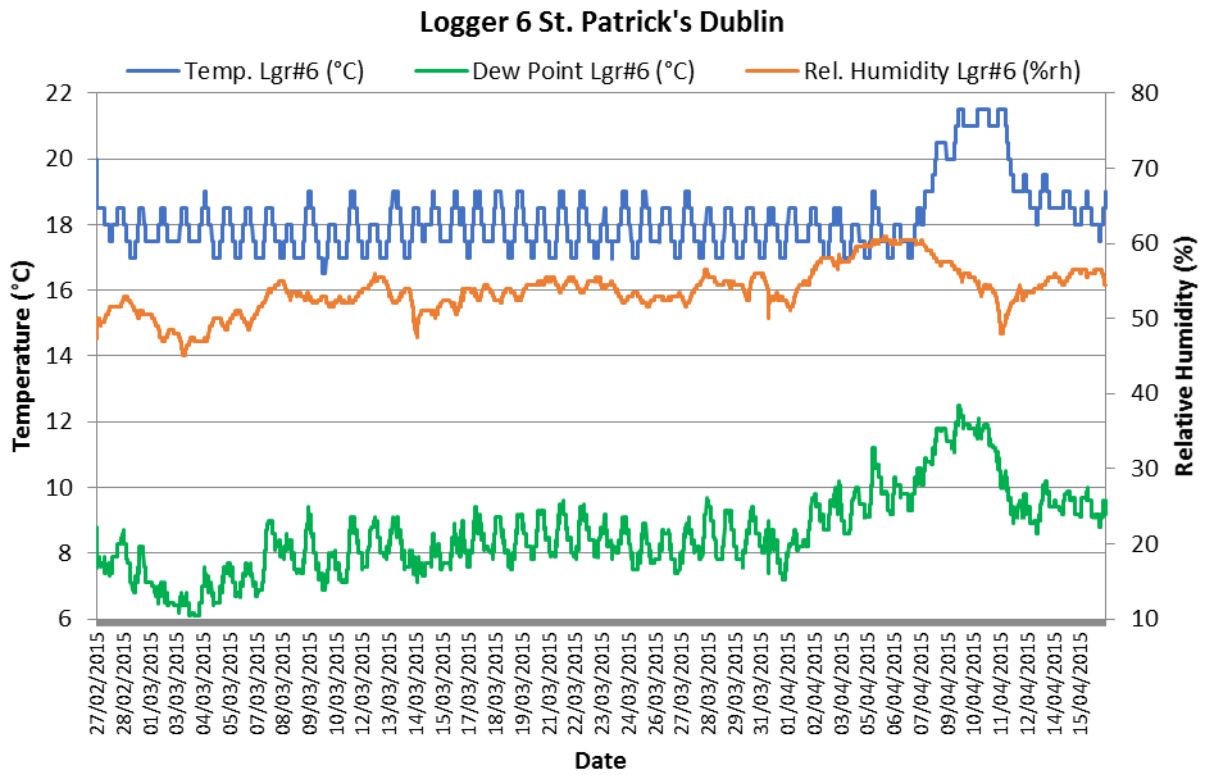

Appendix 1.3 – Tinytag graph (outside T and RH)

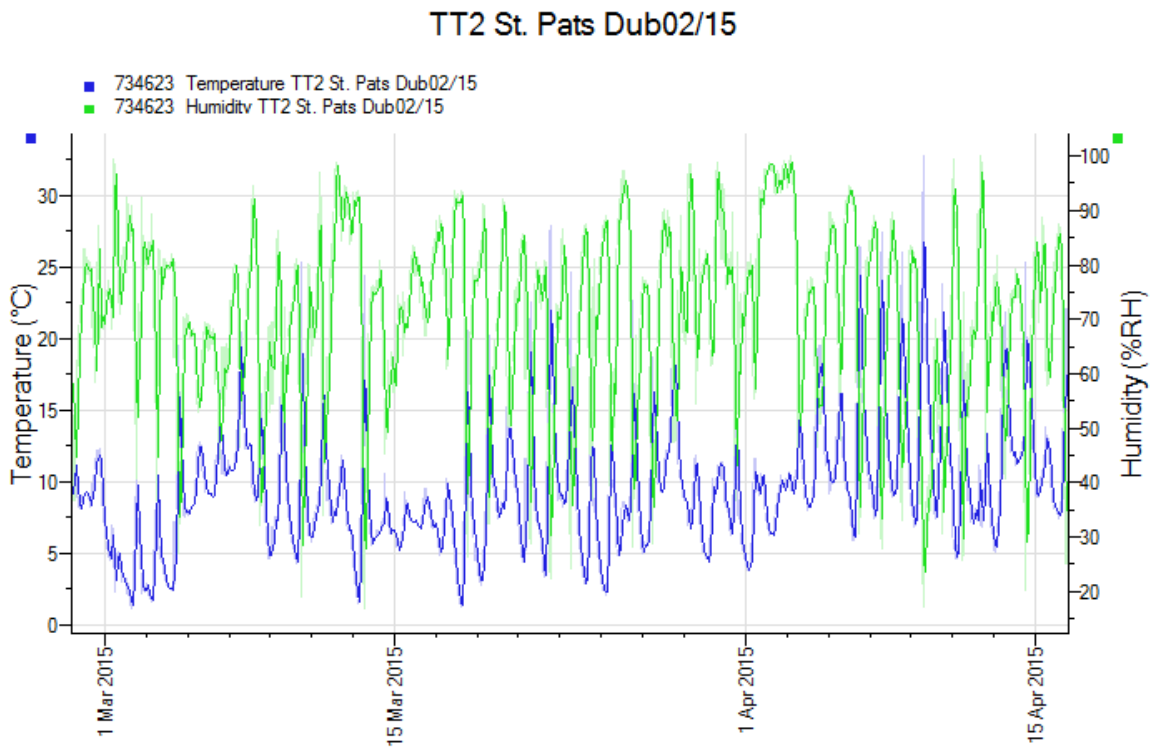

Appendix 2 – St. Canice’s Church of Ireland Cathedral

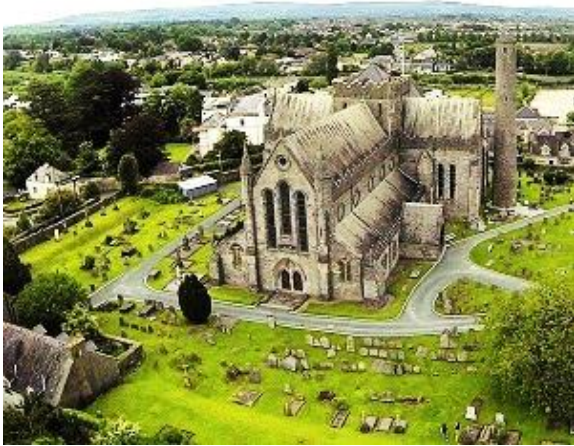

Source: Cathedral website

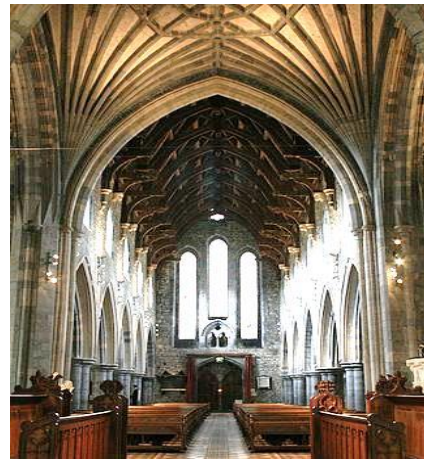

Author: Andreas F. Borchert (CC BY-SA 3.0 de)

Kilkenny

Name: The cathedral Church of St. Canice.

Location: Kilkenny City, Republic of Ireland.

Tradition: Church of Ireland.

Outline history: St. Canice's cathedral is one of Ireland largest and oldest medieval cathedrals. The site was founded in the 6th century and the cathedral was built in the middle of the 12th century. The round tower beside the cathedral was built between 700 and 1,000 and the tower is the oldest surviving building in Kilkenny. The cathedral is named after St. Canice (520-599) who was a friend of another famous Irish saint namely Saint Columba (521-597).

The cathedral and the town suffered greatly under Cromwell's forces in 1650 when all of the stained glass in the cathedral was smashed. Apparently Cromwell's forces used the cathedral as stables for their horses. The cathedral remained in a derelict state for some 12 years after this event and indeed was barely kept open over the next two centuries although it was not derelict. . A major restoration took place in 1864 and continued for many years after that. Fortunately the restoration was done in a sympathetic way and the building seen today is much as it would have looked when constructed. The cathedral is the cathedral church of the Diocese of Cashel, Waterford and Lismore.

This is a cruciform building with a central nave and side aisles. It has a tiles and marble floor and many single glazed stained glass windows. In spite of many restorations it still largely looks as it would when built in the mid 12th century. It has a wooden ceiling below a tiles roof. There are many wooden fittings including the pews, choir stalls and bishops seat.

Appendix 2.1A – Floor plan with loggers and TinyTag location

(A) SUMMER

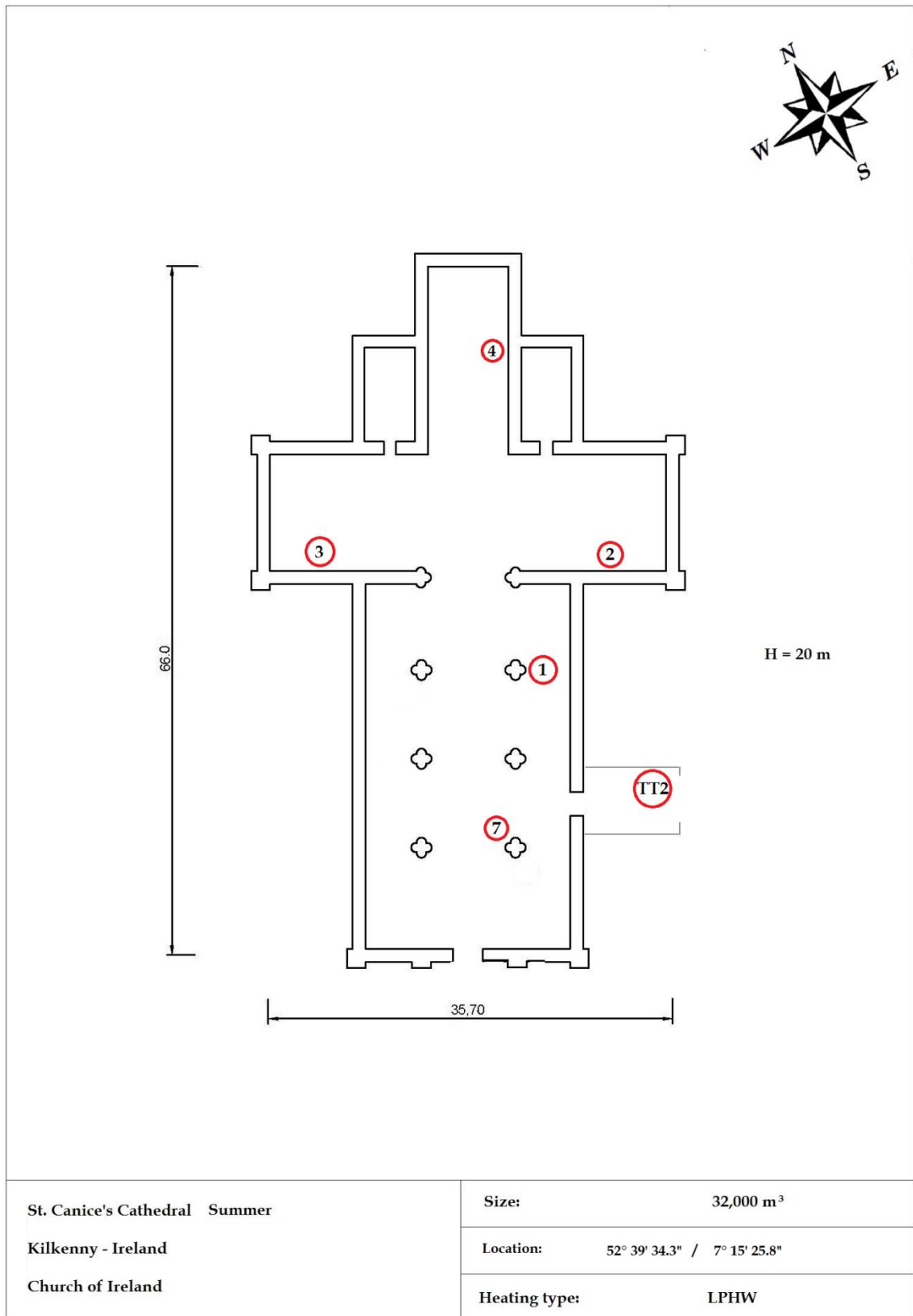

Appendix 2.2A – Loggers' graphs

Logger 1 - St. Canice's (summer)

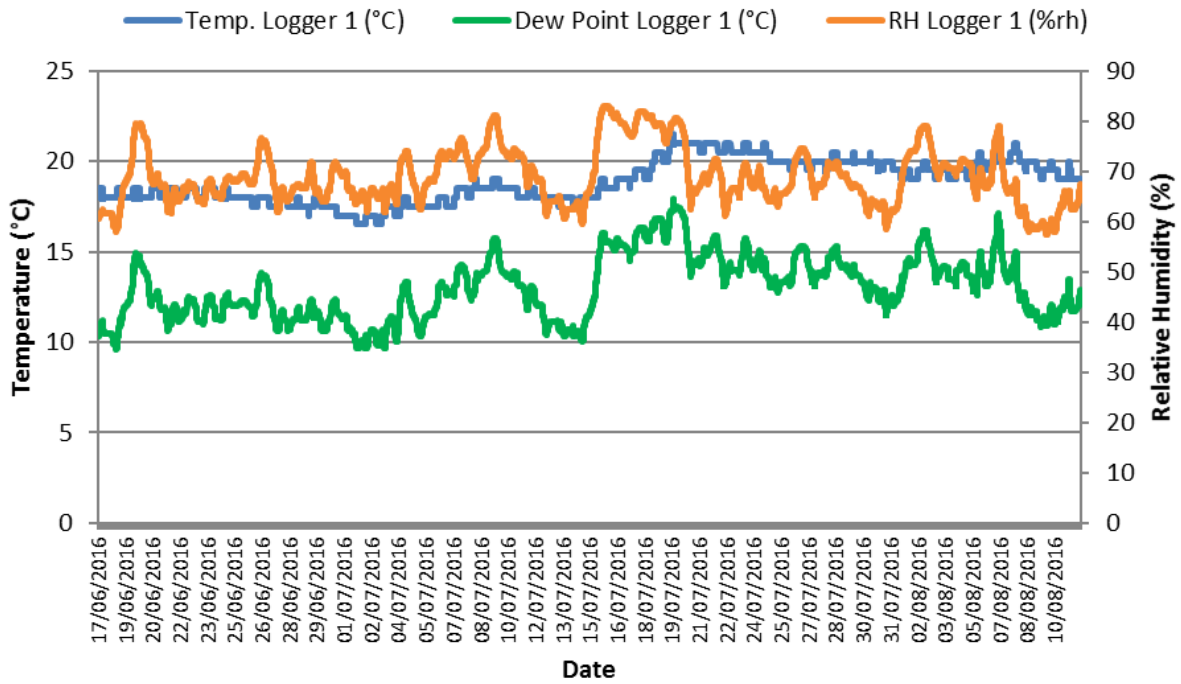

Logger 2 - St. Canice's (summer)

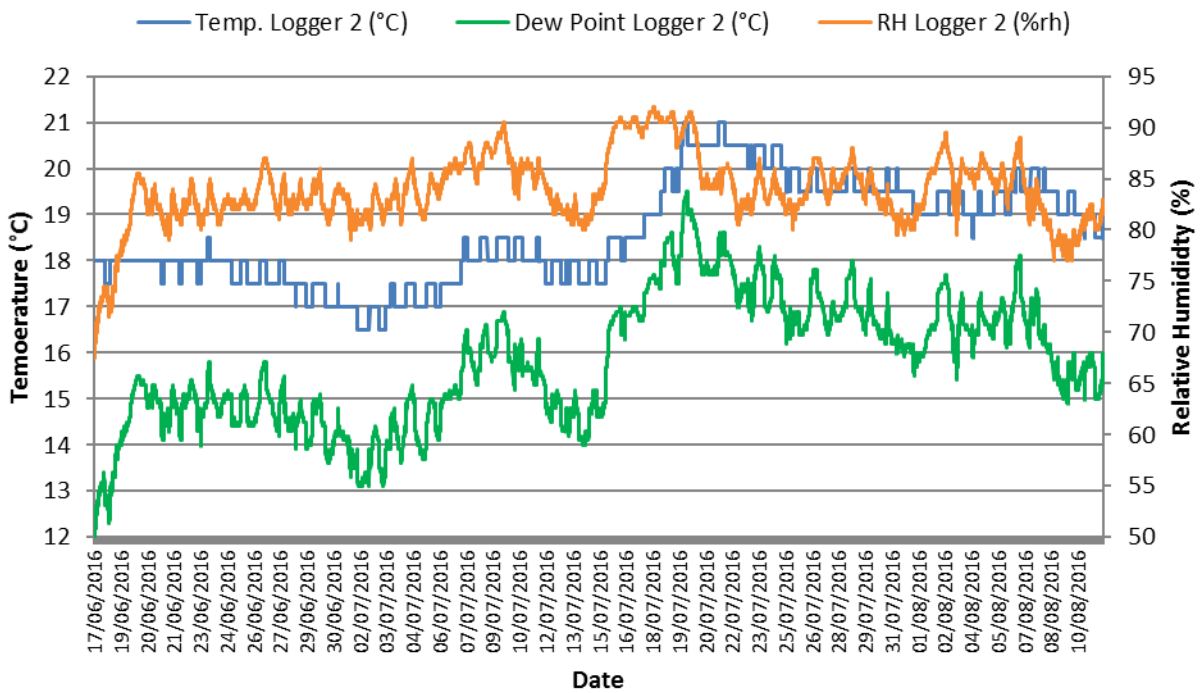

Logger 3 - St. Canice's (summer)

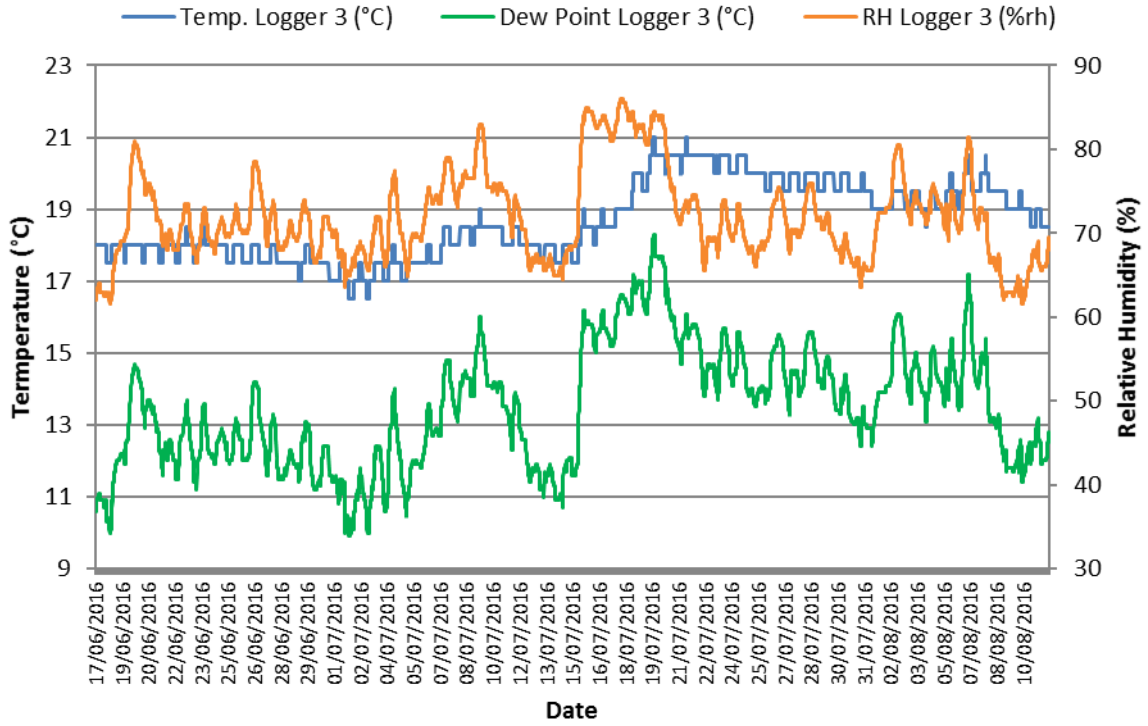

Logger 4 - St. Canice's (summer)

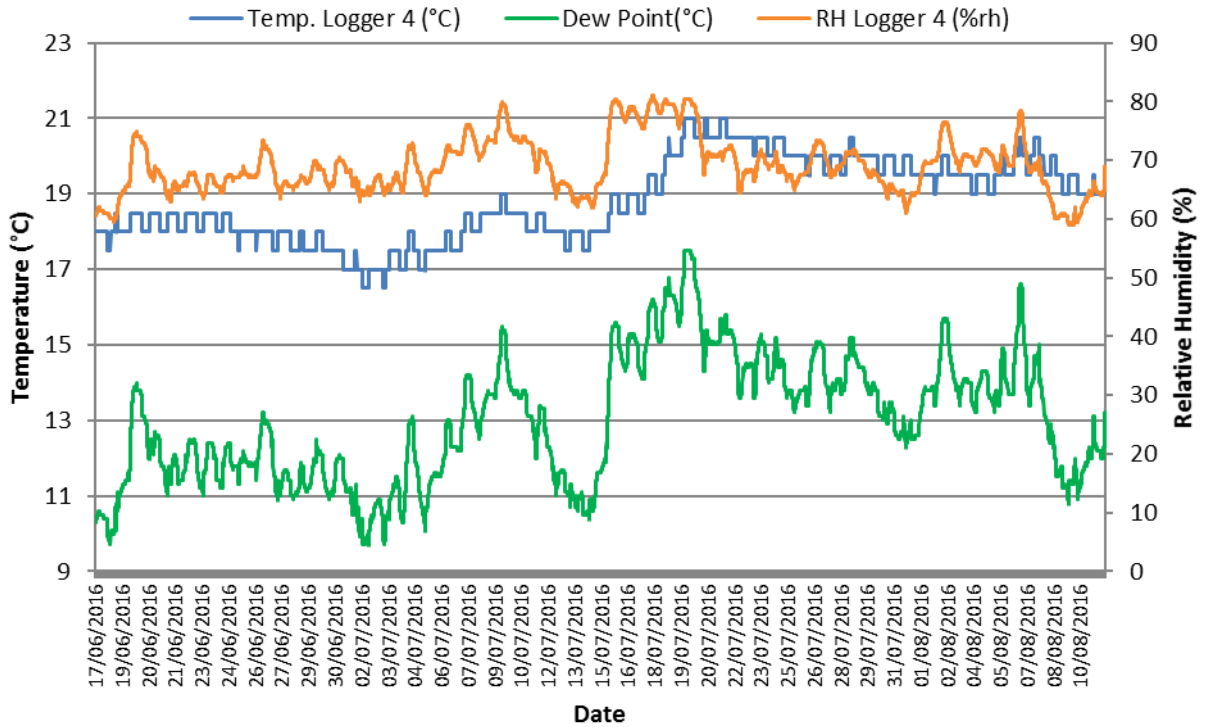

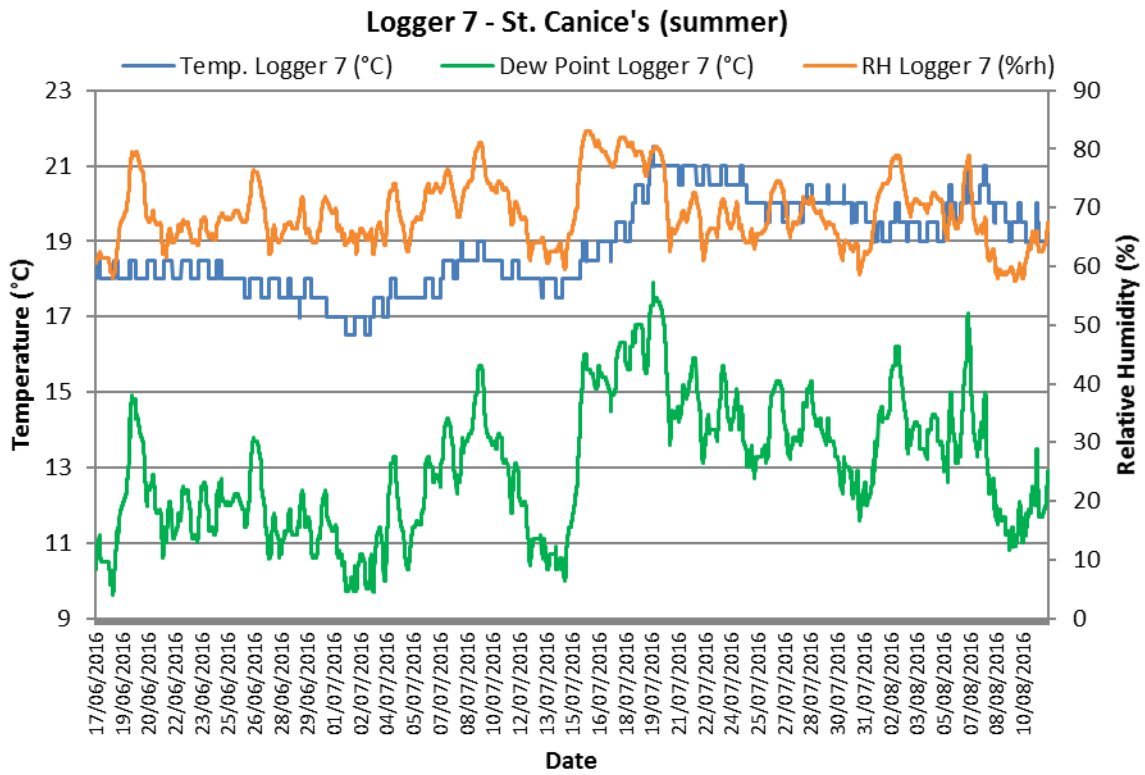

Appendix 2.3A – Tinytag graph (outside T and RH)

TT2 St. Can. Sum

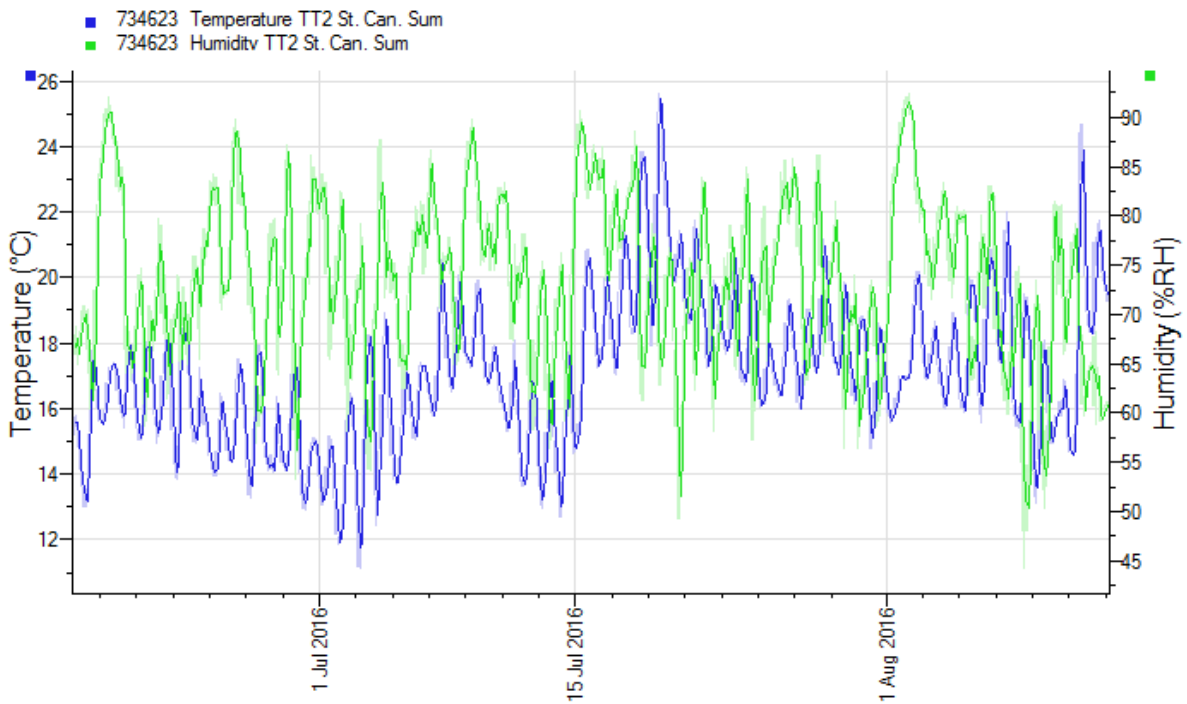

Appendix 2.1B – Floor plan with loggers and TinyTag location

(B) WINTER

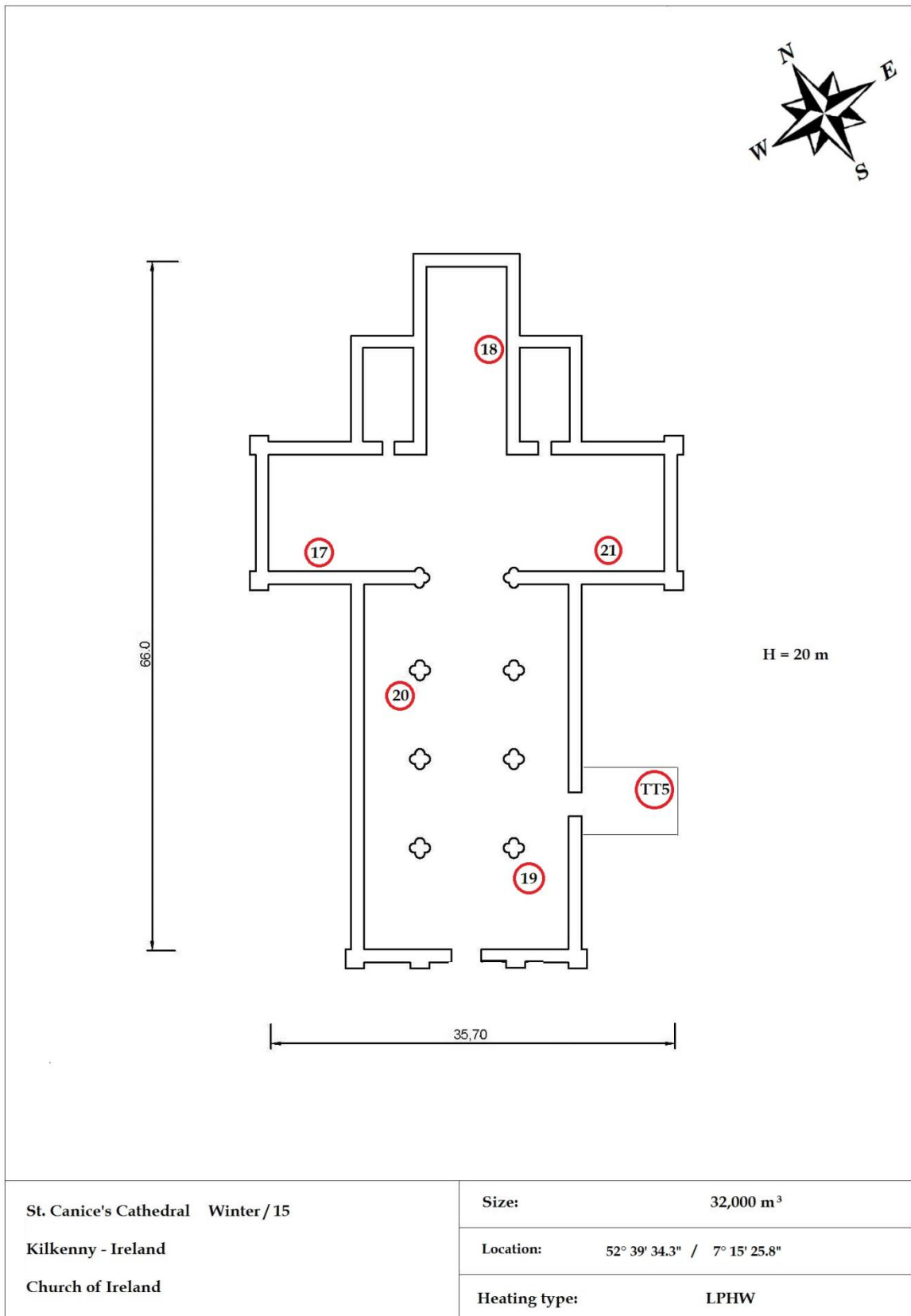

Appendix 2.2B – Loggers' graphs

Logger 17 - St. Canice's (winter)

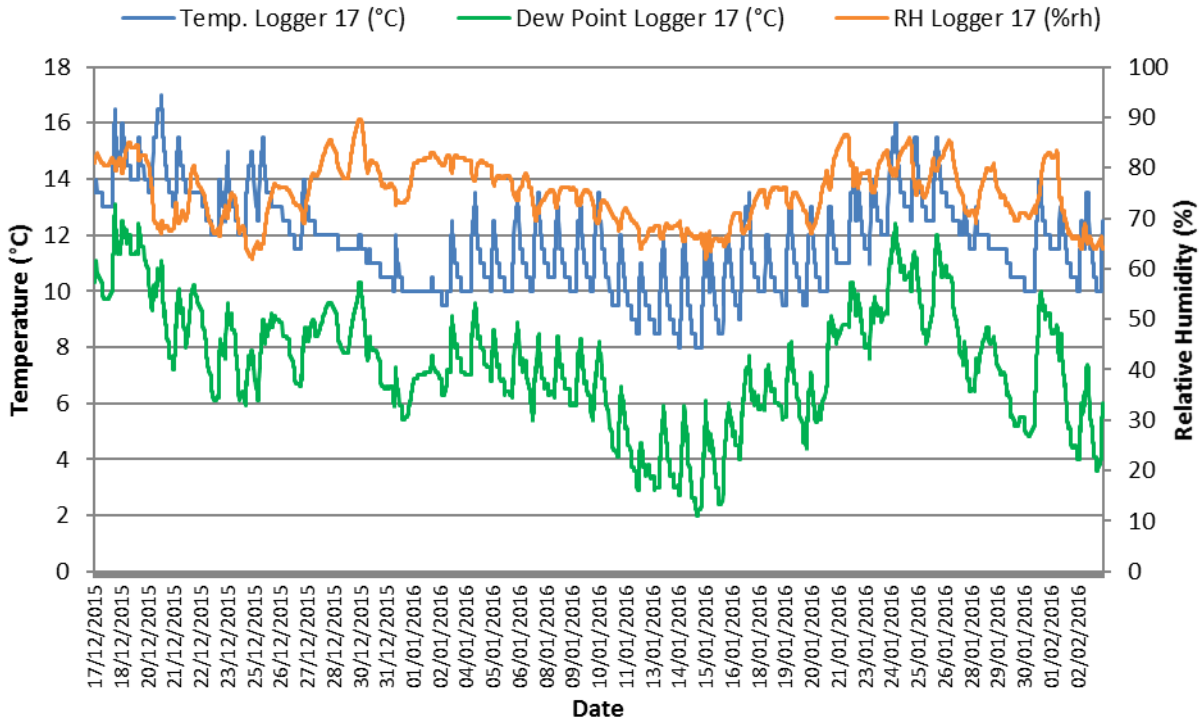

Logger 18 St. Canice's (winter)

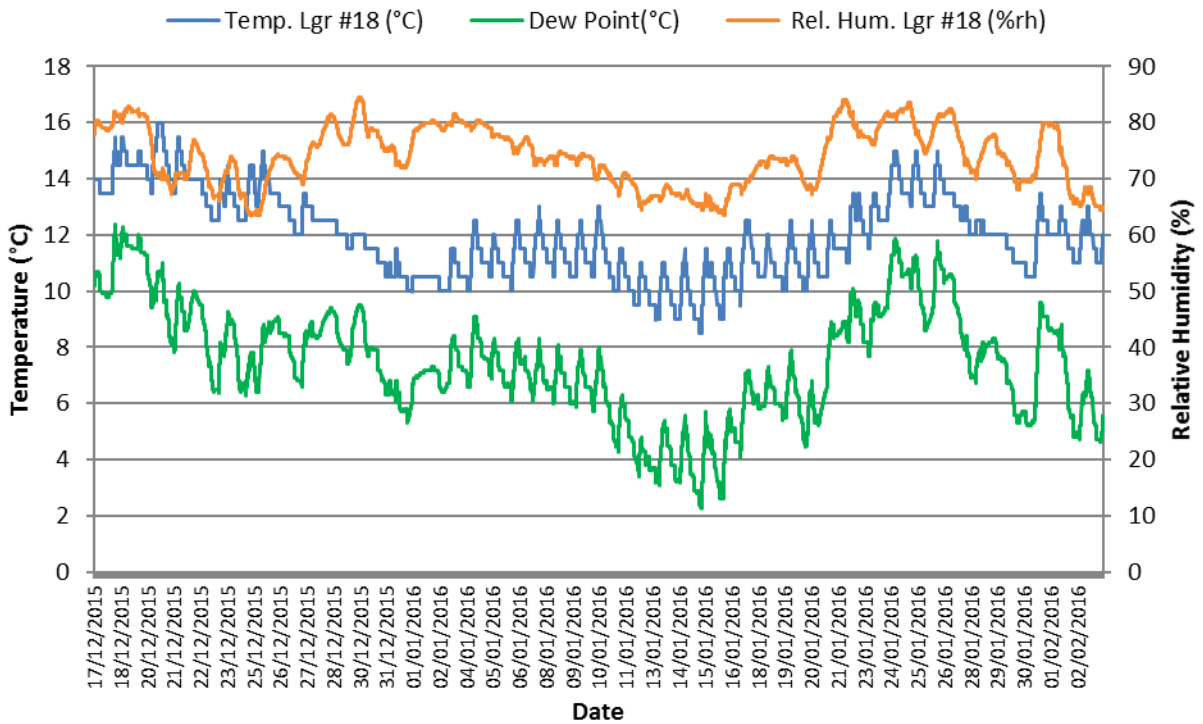

Logger 19 St. Canice's (winter)

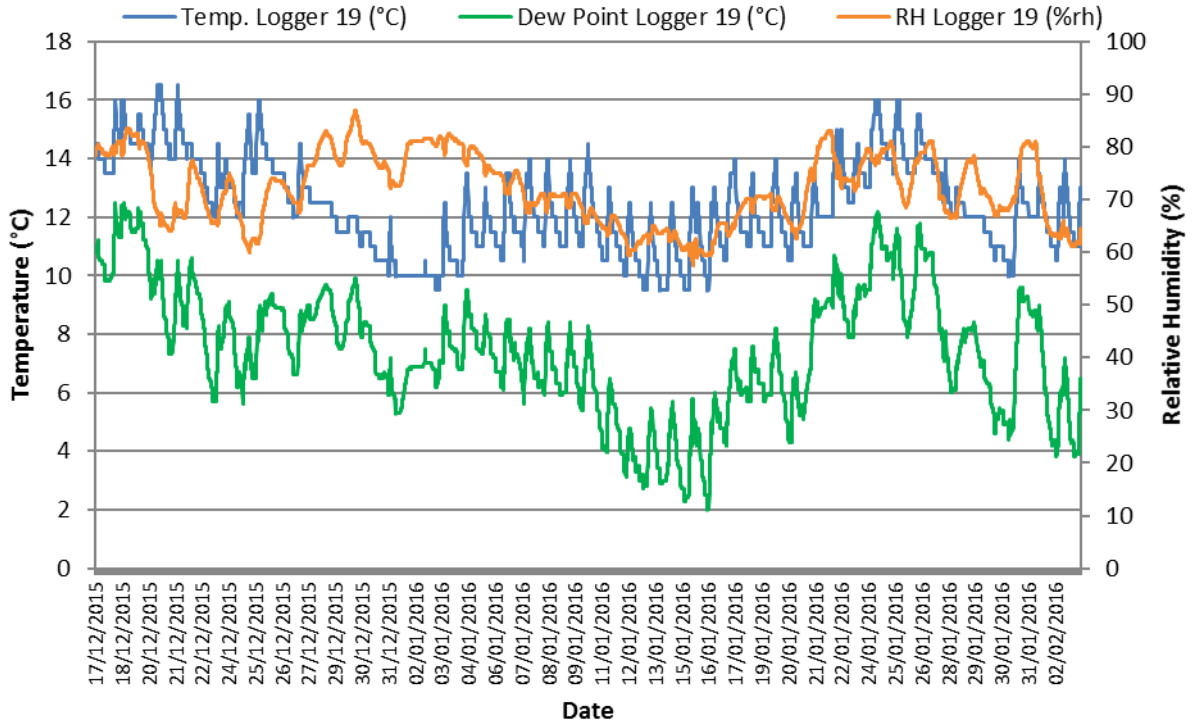

Logger 20 - St. Canice's (winter)

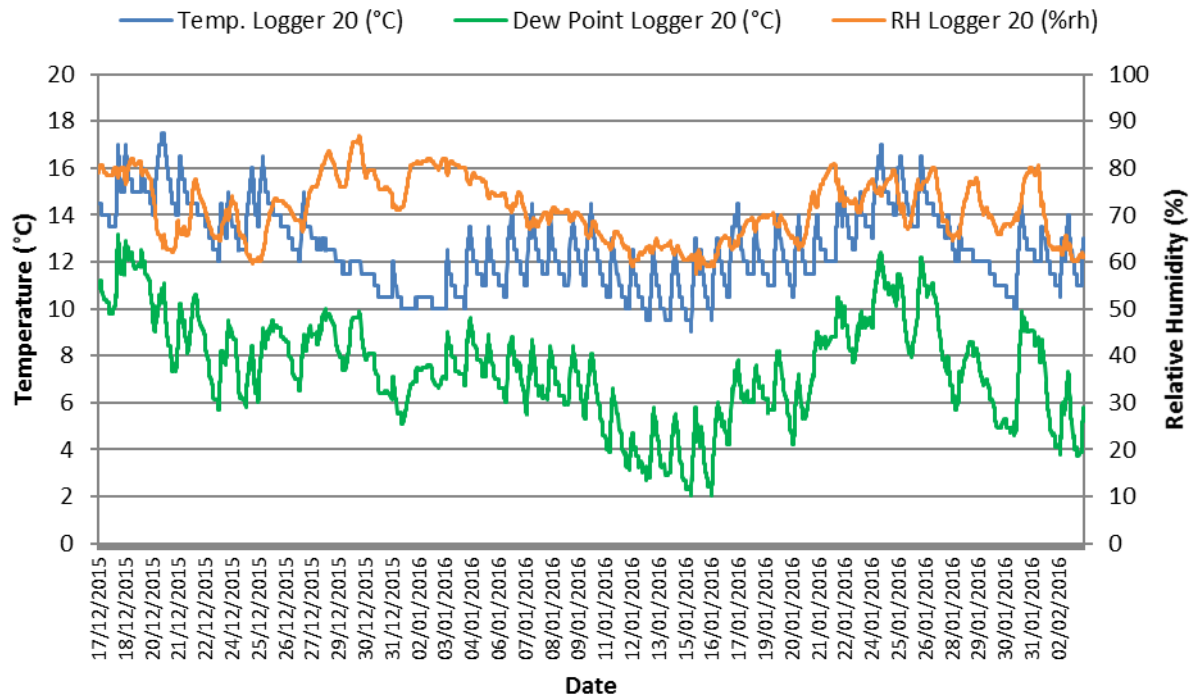

Logger 21 - St. Canice's (winter)

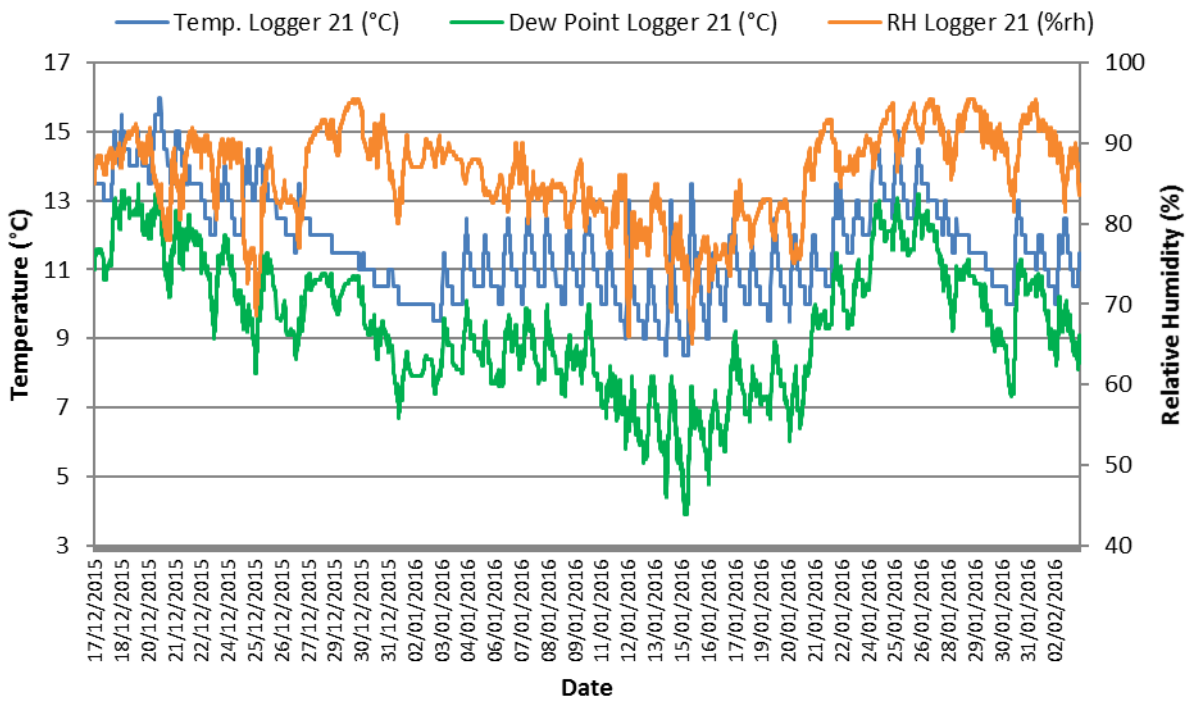

Appendix 2.3B – Tinytag graph (outside T and RH)

TT5K'KennyCanice

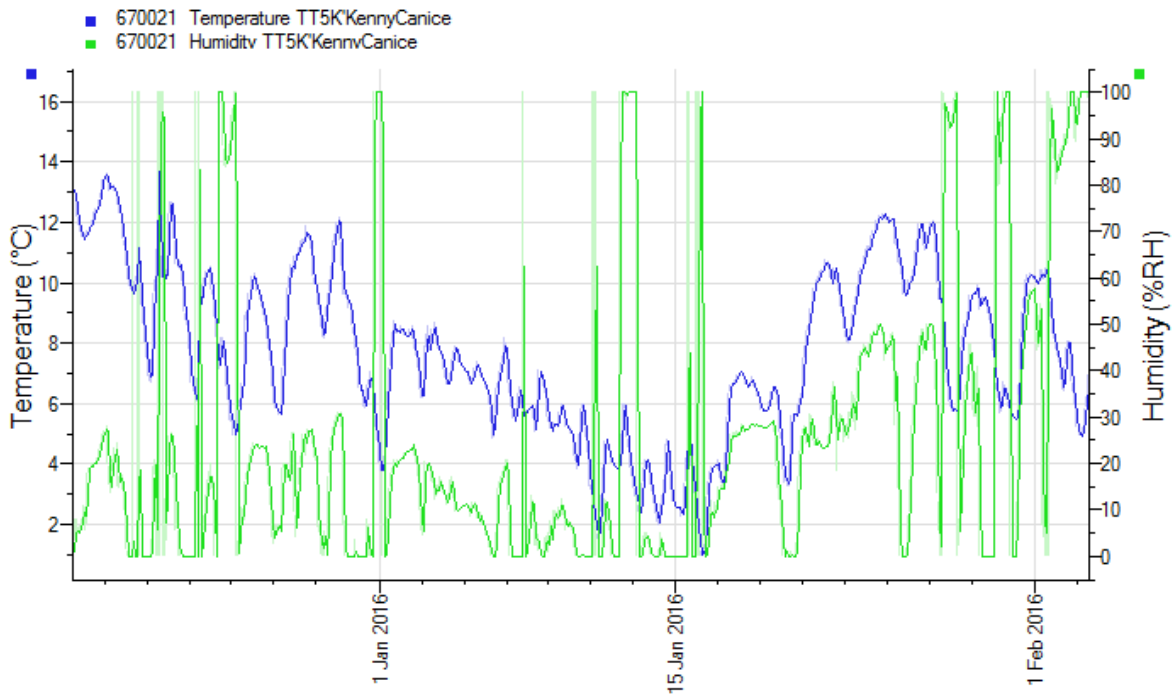

Appendix 3 – St. Anne’s Church of Ireland Cathedral

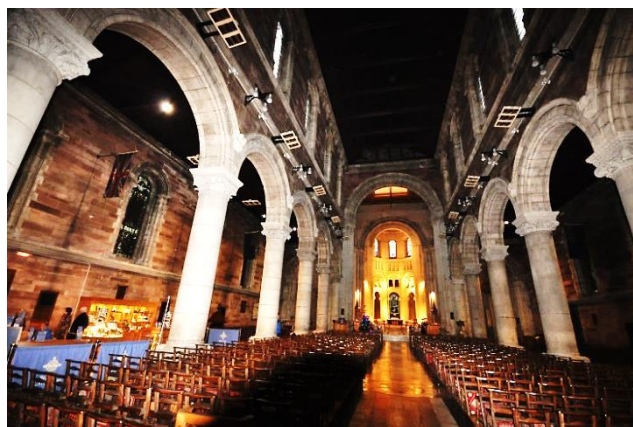

Belfast

Name: The Cathedral Church of St. Anne.

Location: Belfast City, Northern Ireland.

Tradition: Church of Ireland.

Outline history: Belfast cathedral was built largely as a result of the rapid increase in size of the city of Belfast during the industrial revolution. At one stage Belfast had the largest rope works, linen works and ship building yards in the world. Belfast however falls between two existing diocese namely Connor and Down each of which has its own cathedral. Parts of Belfast fall within each diocese. It was decided though that the size and importance of the city justified its having its own cathedral and work started on the building in 1899. There was a parish church on the site namely St. Anne's and the cathedral was built around this existing building. The current cathedral was originally designed as a Gothic building but the plans were changed and it is now a Romanesque design but in some ways looks like a basilica. The building progressed slowly with the nave being completed in 1904 and succeeding architects completed various different parts of the building until building stopped in the 1970s because of lack of funds. The building was finally completed in 1981 but without a spire or steeple but it does now have a spike on top of the building.

This is a cruciform church with side aisles and chapels. It also has a columbarium beneath the sanctuary. The building has a spire rather than a tower due to it being built in an area subject to subsidence. It has a wooden ceiling, wooden pews and a tiled floor. The windows, many stained glass, are single glazed.

Appendix 3.1 – Floor plan with loggers and TinyTag location

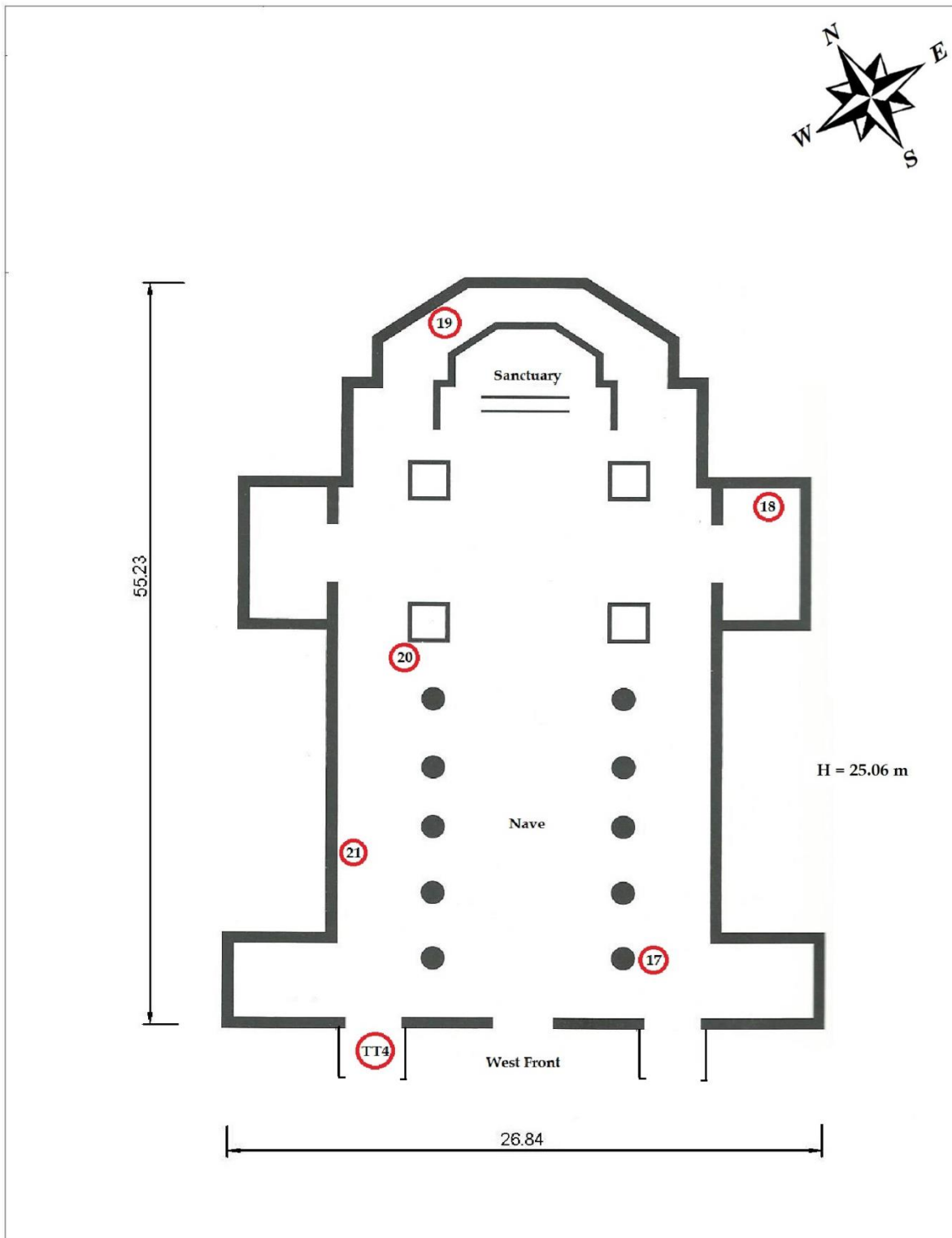

St. Anne's Cathedral Belfast - Northern Ireland Church of Ireland	Size:	37,000 m ³
	Location:	54° 36' 10" / 5° 55' 42" W
	Heating type:	Radiant heaters

Appendix 3.2 – Loggers' graphs

Logger 17 St. Anne's Belfast

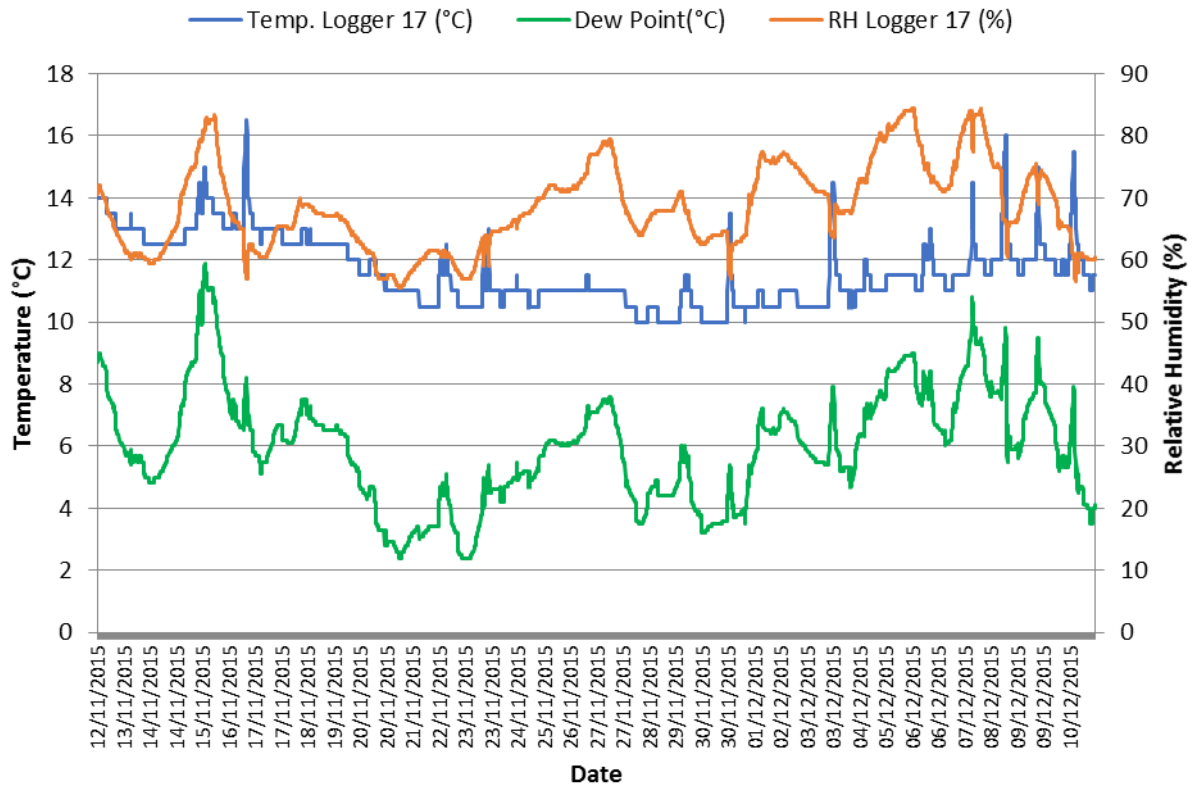

Logger18 St. Anne's Belfast

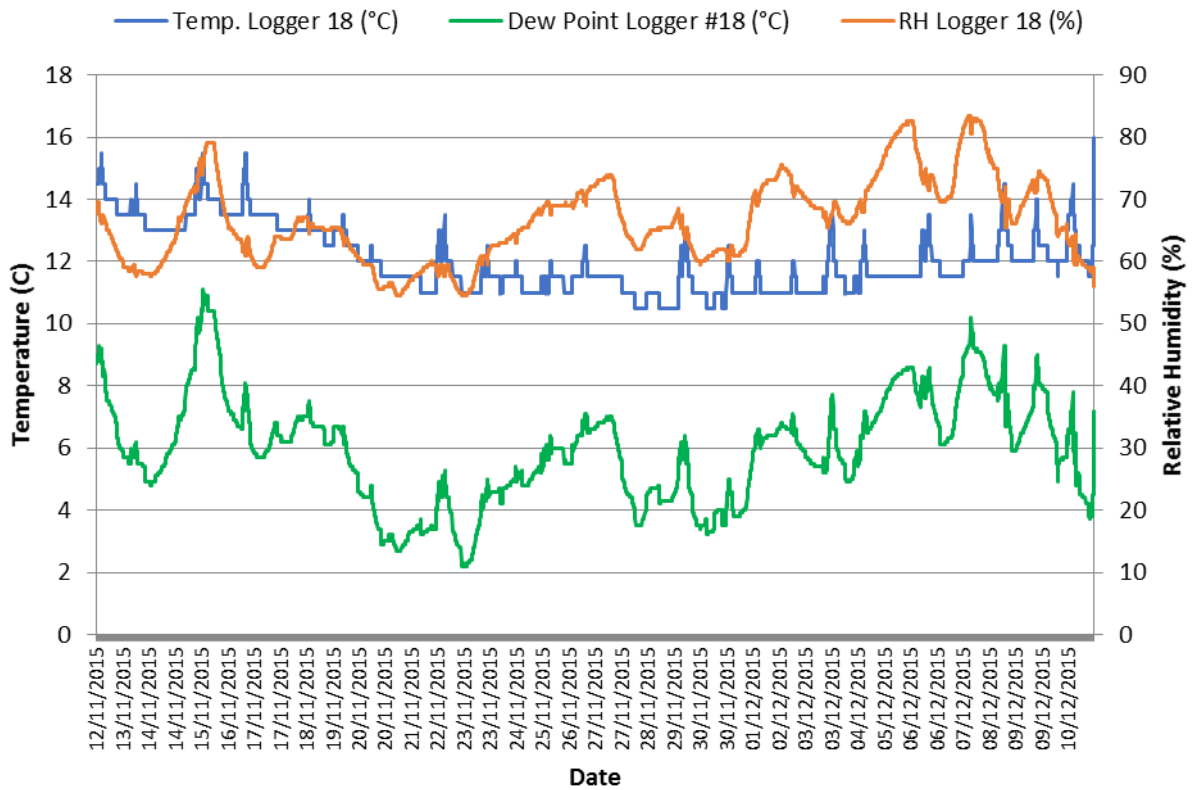

Logger 19 St. Anne's Belfast

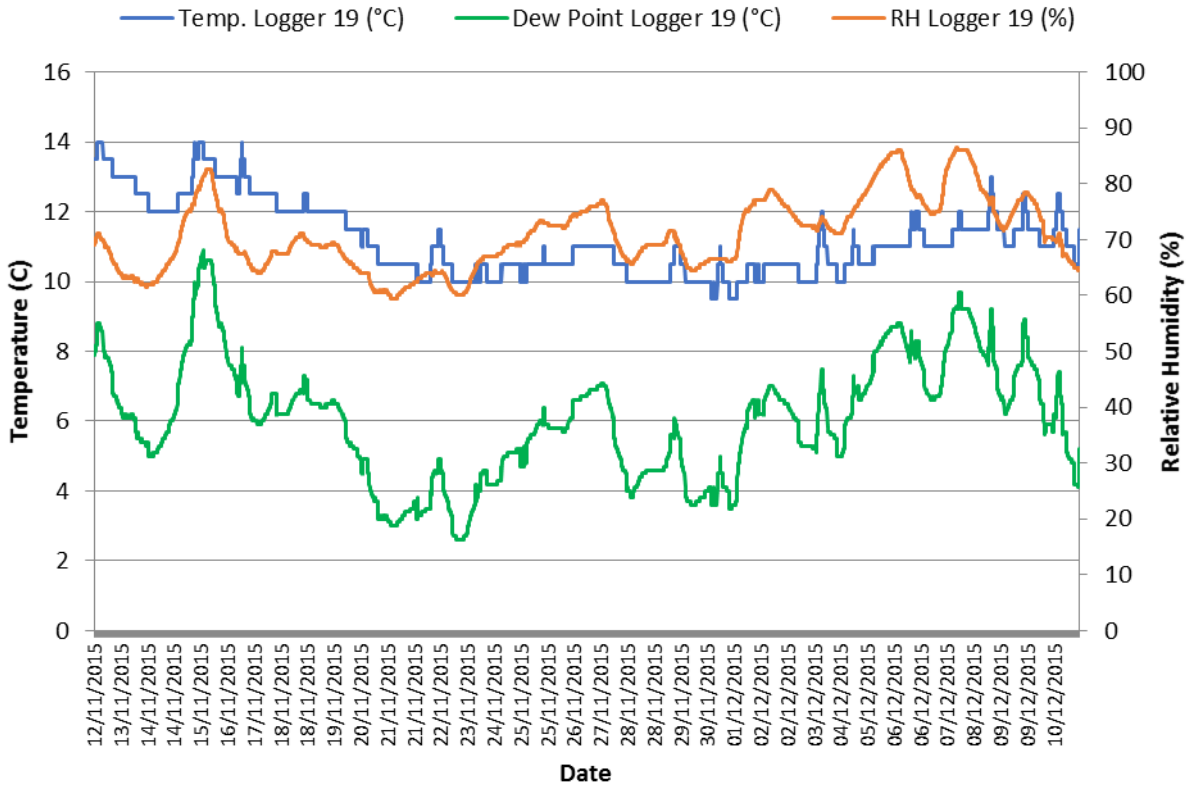

Logger20 St. Anne's Belfast

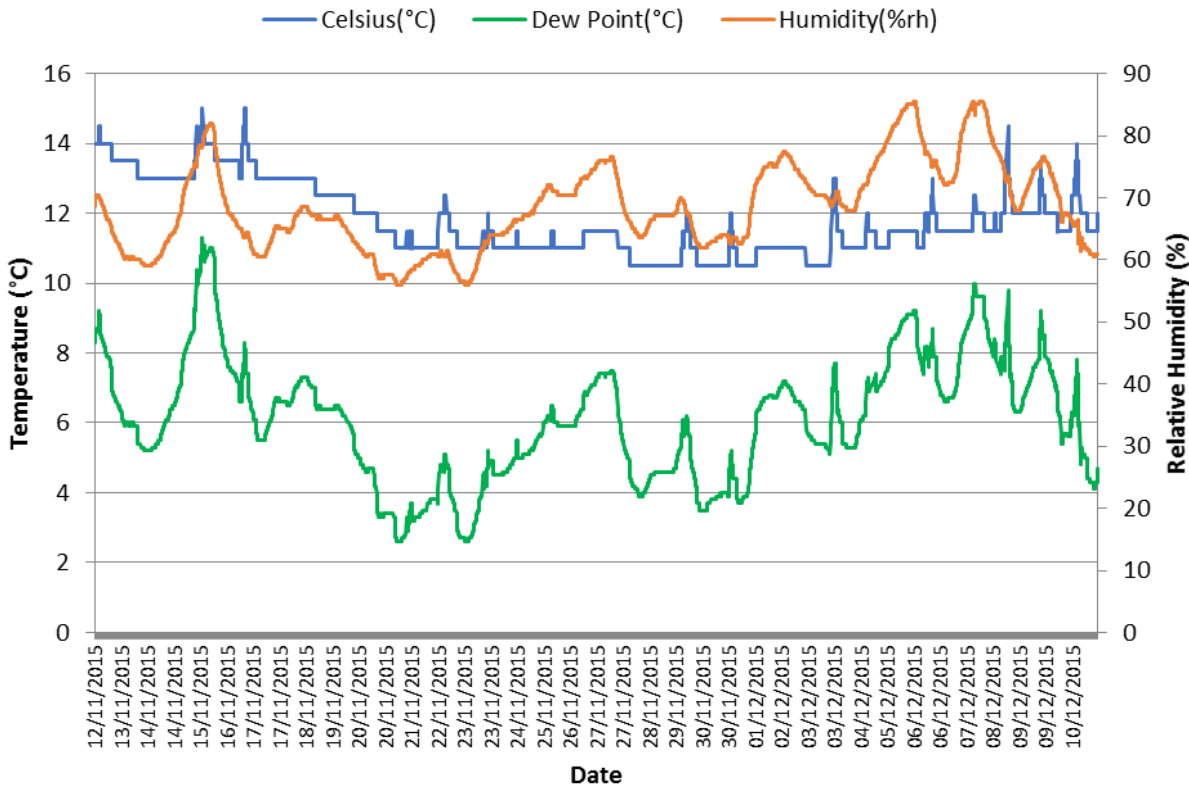

Logger 21 St. Anne's Belfast

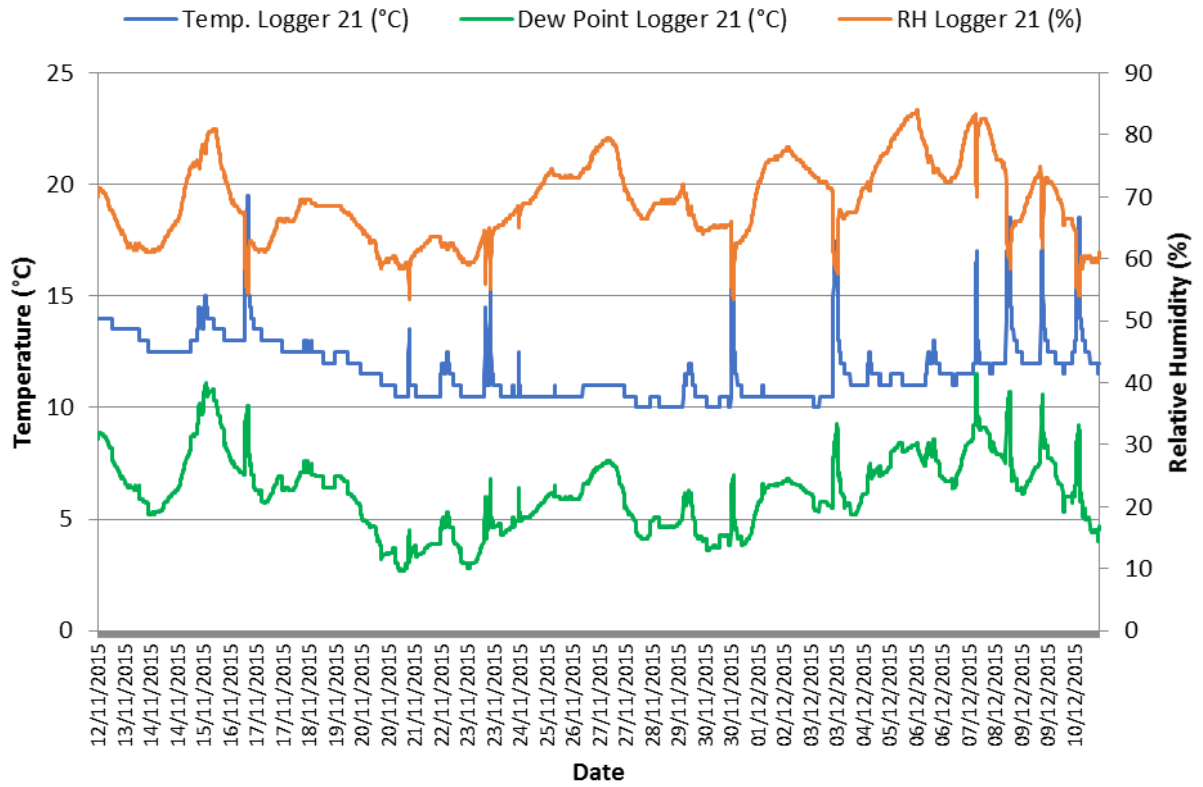

Appendix 3.3 – Tinytag graph (outside T and RH)

TT4 St. Anne's Bfst

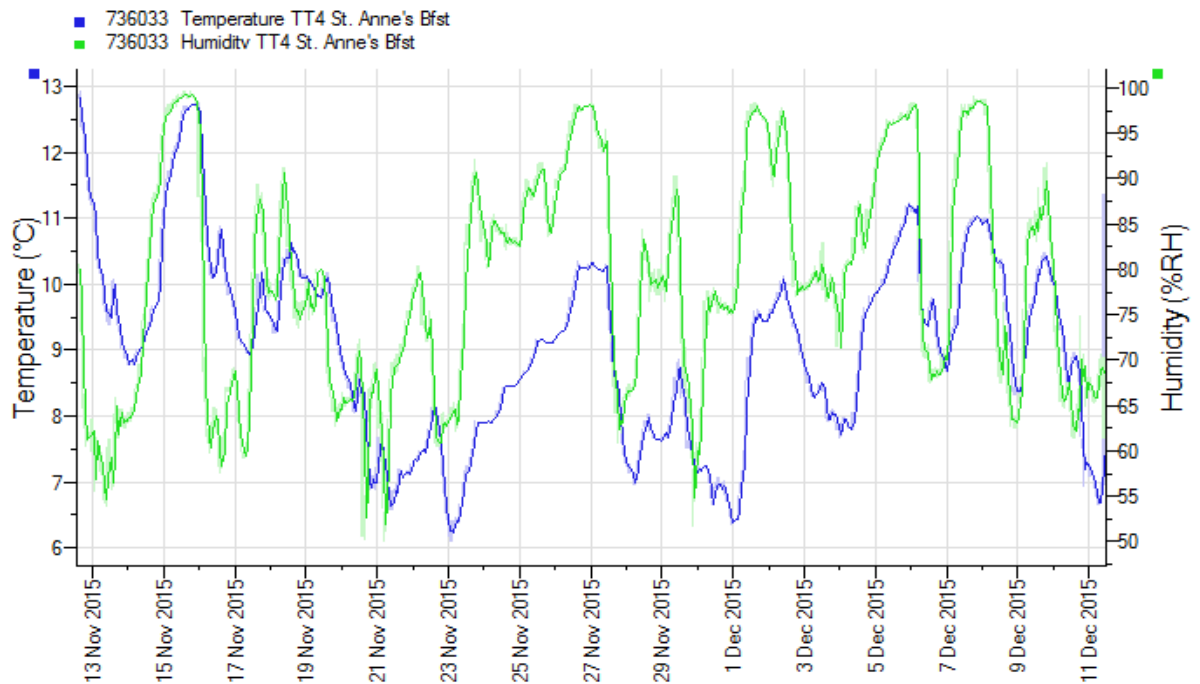

Appendix 4 – Our Lady Assumed into Heaven and St. Nicholas Roman Catholic Cathedral

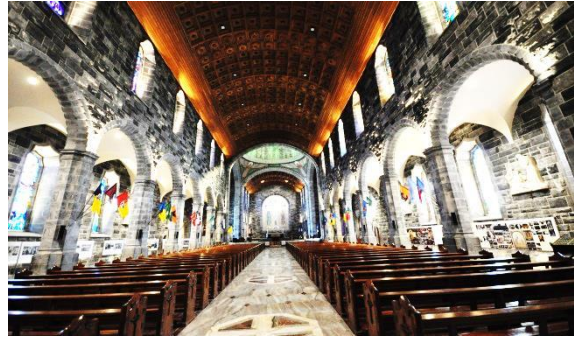

Galway

Name: Our Lady Assumed into Heaven and St. Nicholas Cathedral.

Location: Galway City, Republic of Ireland.

Tradition: Roman Catholic.

Outline History: Galway cathedral was dedicated on 15 August 1965 making it one of Europe's youngest cathedrals. It follows no particular architectural style but has Iberian influences which reflect Galway's long trading relationship with that region. The cathedral is built on an island and on the site of the old city gaol which was given to the church by the city council in 1941. Originally the cathedral was to have been built on a site nearby but the Bishop at the time, Bishop Michael Brown said that the original site was too small and would not have enough car parking places which was a great piece of forward thinking. The architect for the cathedral was a John Robinson who had designed a number of churches in Dublin and in the rest of Ireland. The interior of the building was reordered as a result of Vatican II which moved the altar further into the centre of the building. The building did not, and has not met with universal approval regarding its looks. Galway cathedral is the Diocesan cathedral for the Diocese of Galway, Kilmacduagh and Kilfenora. This is a large cruciform cathedral with side aisles. The floor is tiled and the ceiling is painted and wooden with an, insulated, void between the ceiling and the roof. The walls are not plastered and there are some large mosaics on some of the walls. The pews are wooden and the cathedral has a large pipe organ. The building has a central cupola and the many stained glass windows are single glazed.

Appendix 4.1 – Floor plan with loggers and TinyTag location

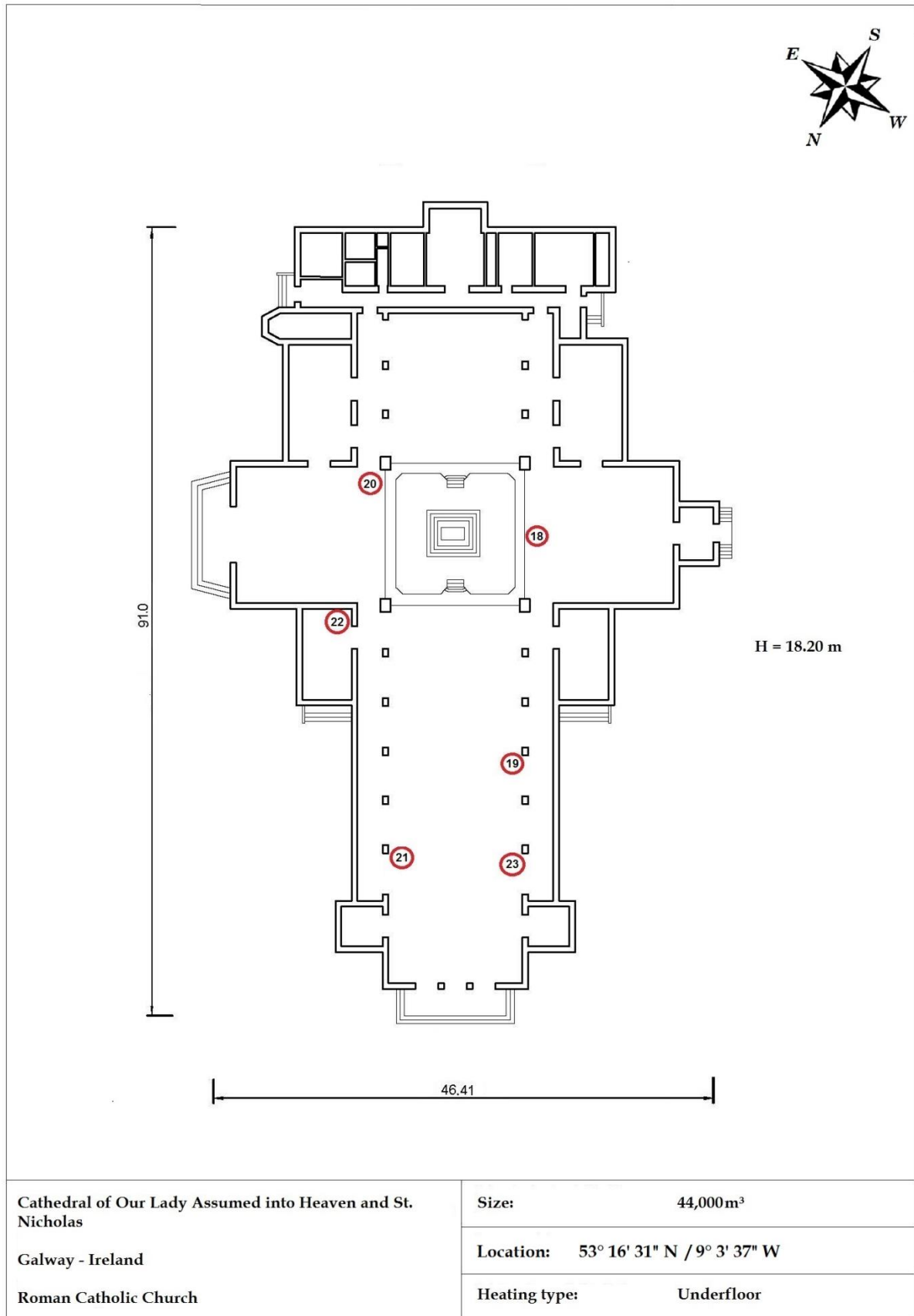

Appendix 4.2 – Loggers’ graphs

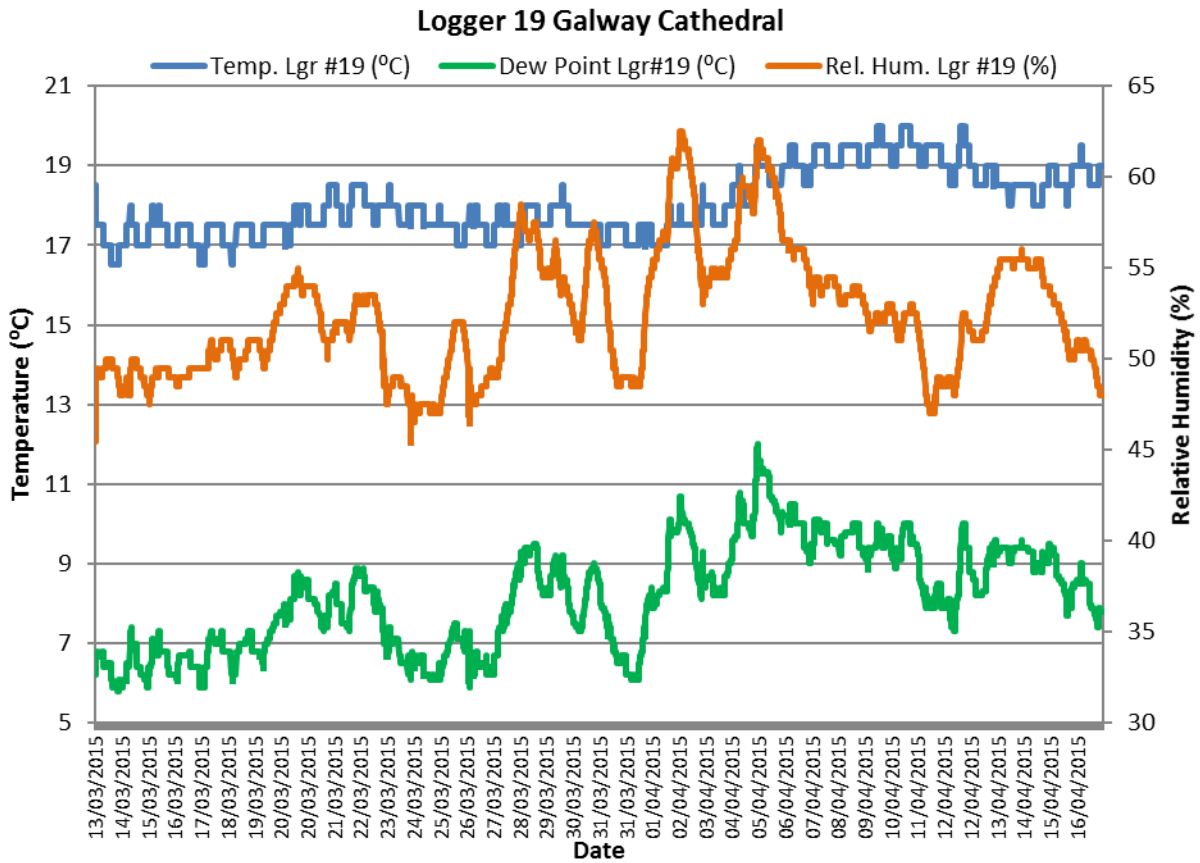
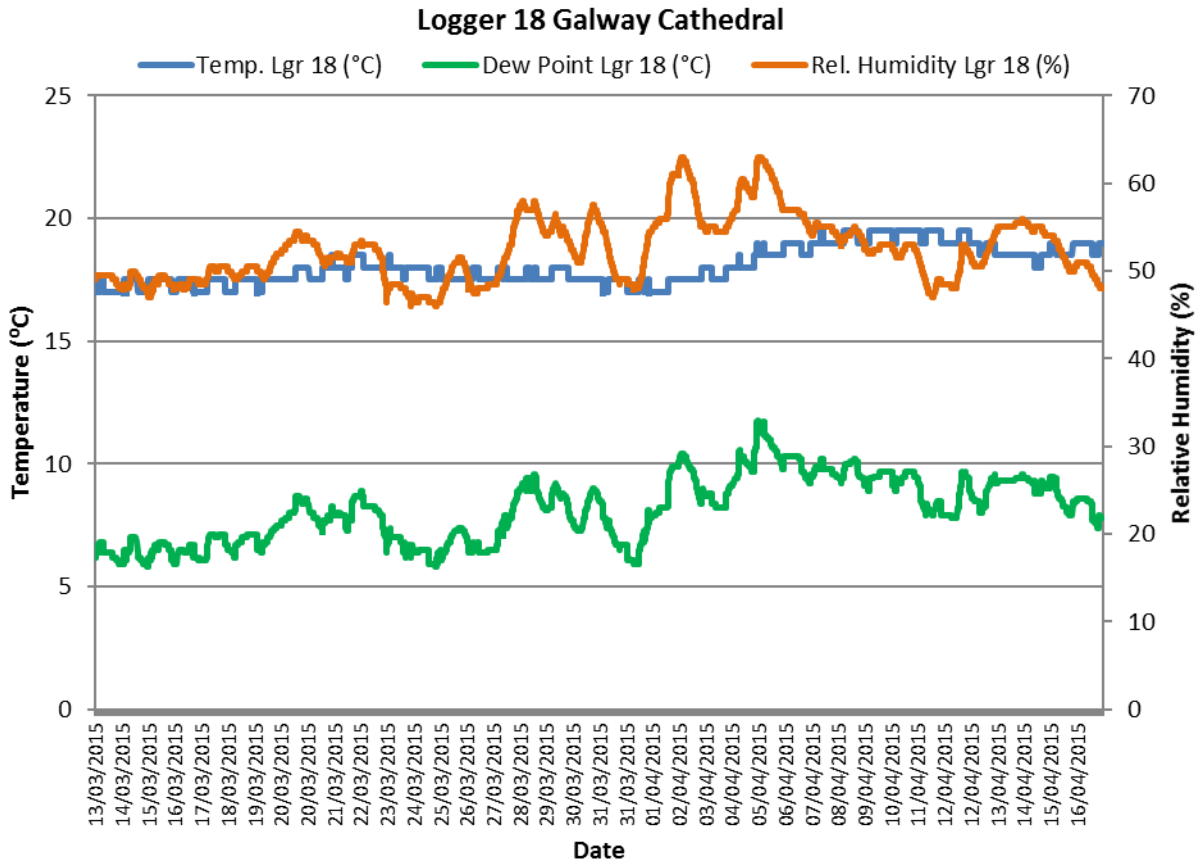

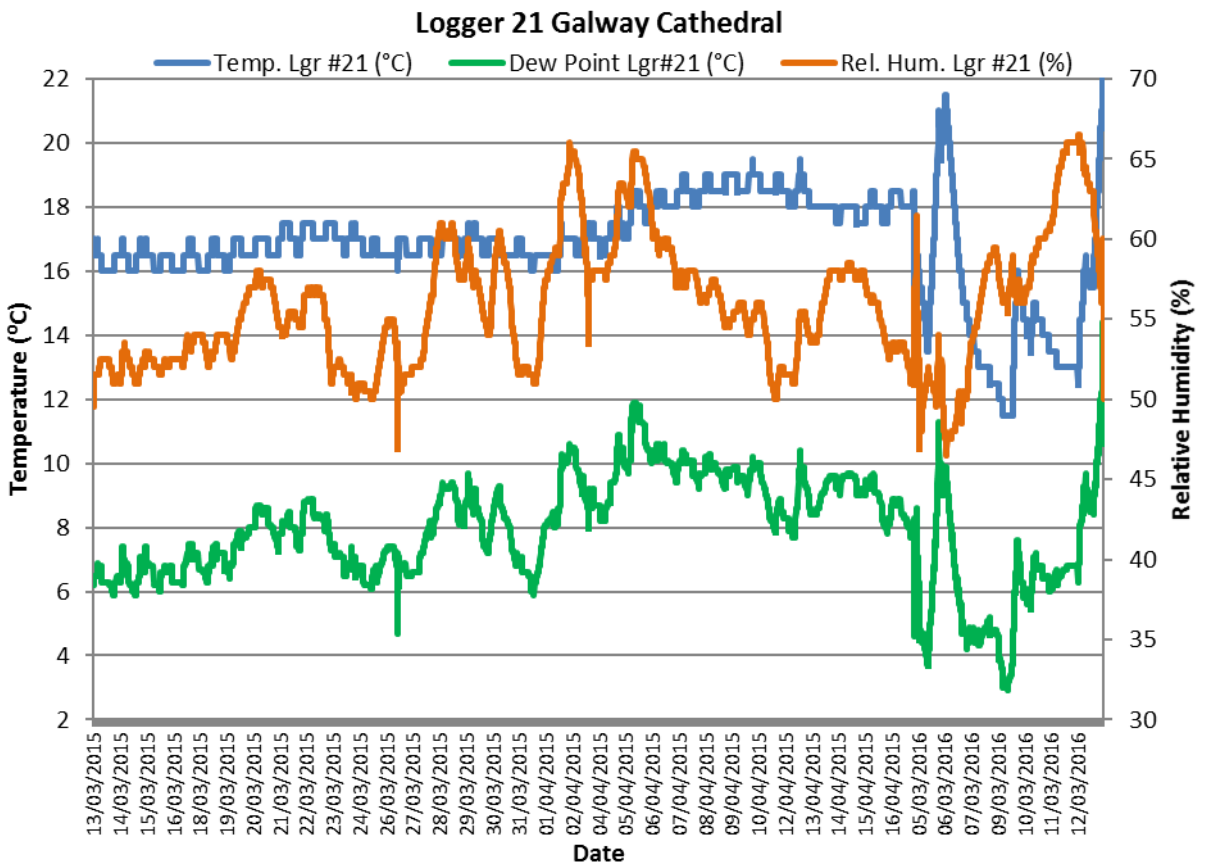
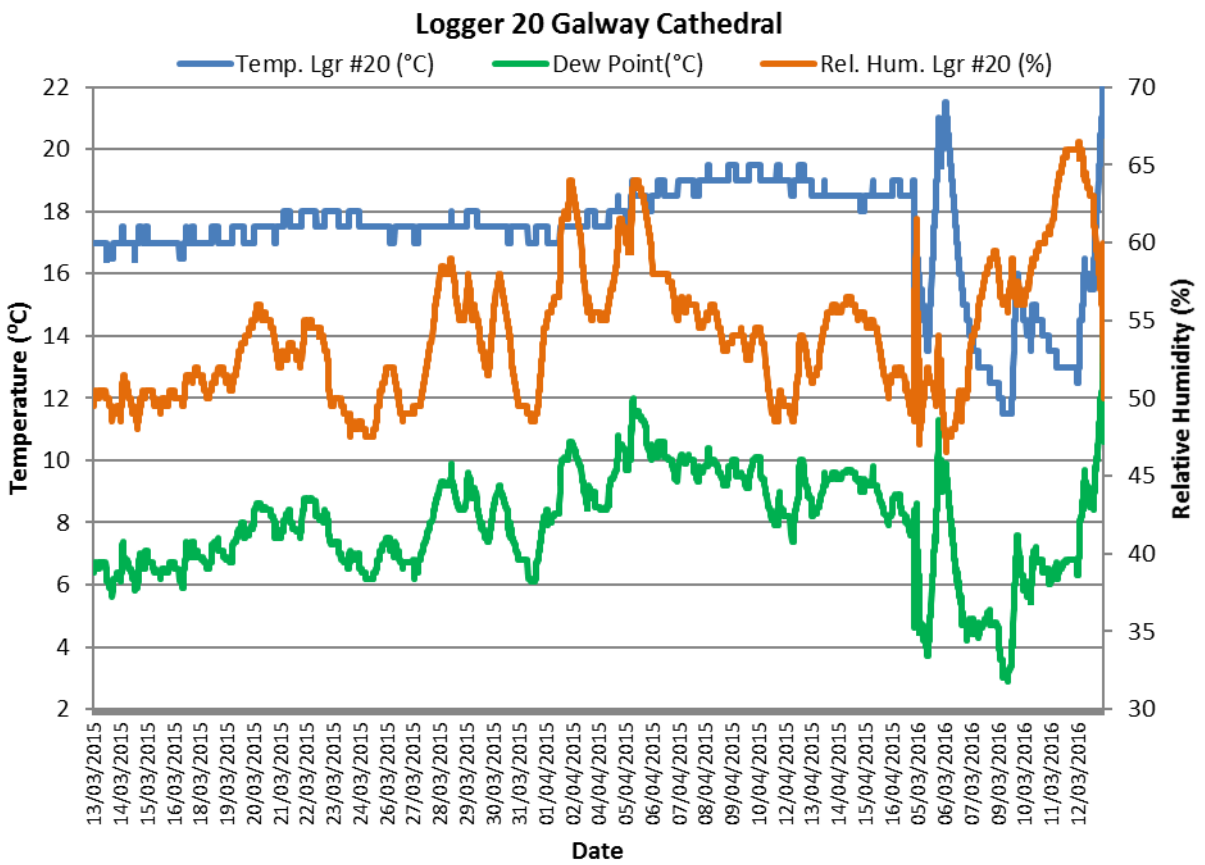

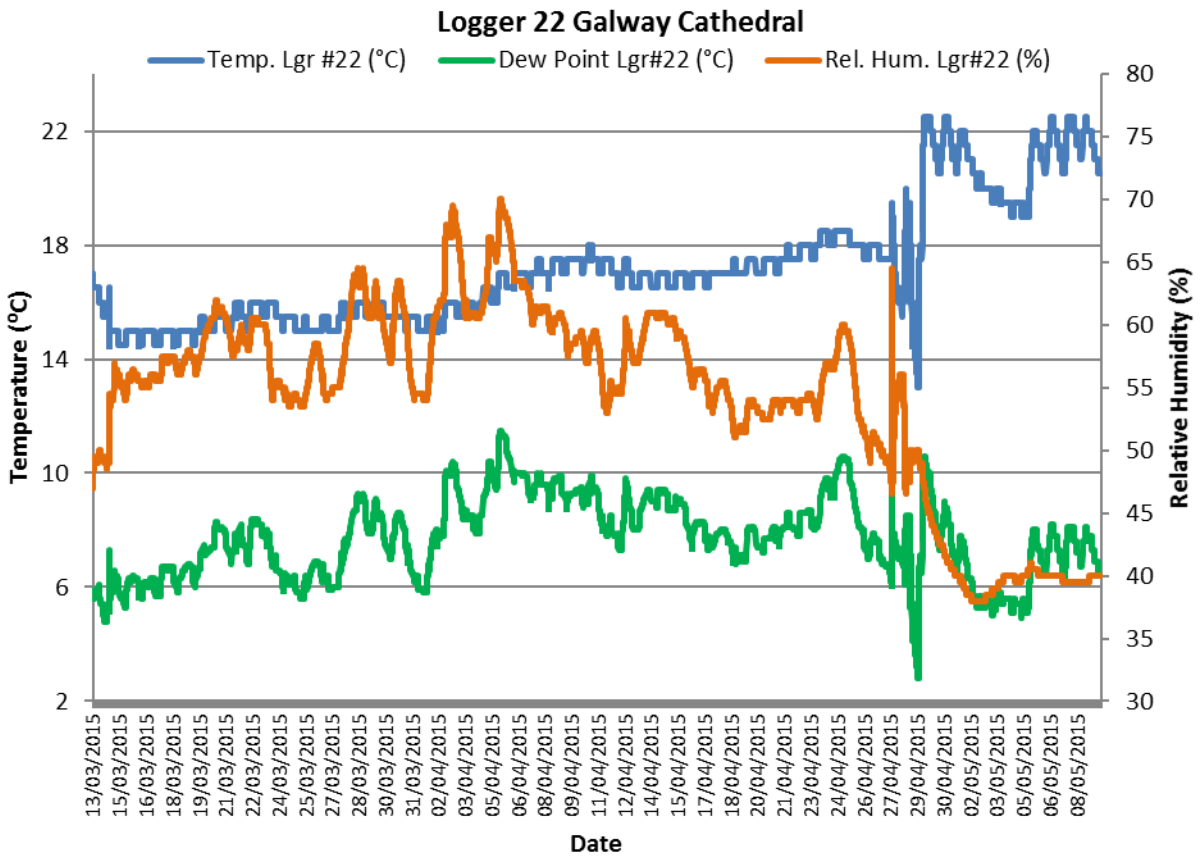

Appendix 4.3 – Tinytag graph (outside T and RH)

TT4 Galway 03/15

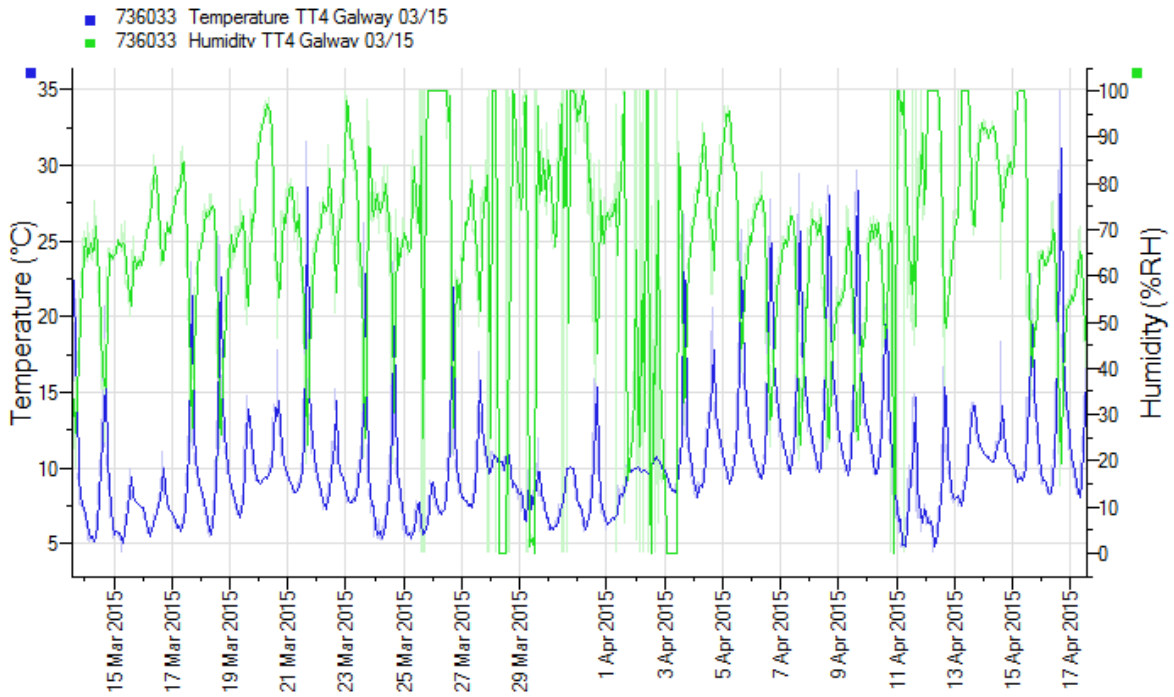

Appendix 5 - St. Patrick's Roman Catholic Cathedral

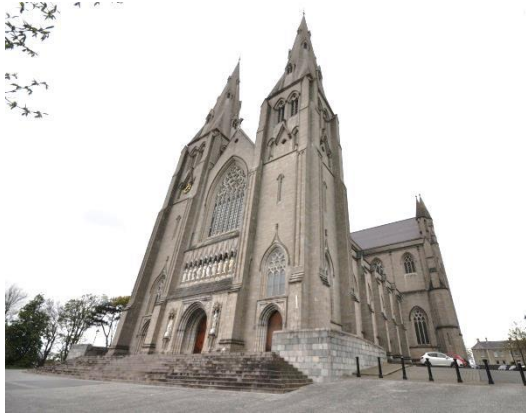

Armagh

Name: The Cathedral Church of St. Patrick.

Location: Armagh City, Northern Ireland.

Tradition: Roman Catholic.

Outline History: St. Patrick's Roman Catholic cathedral is located in a very prominent position on top of a hill in the City of Armagh in Northern Ireland. Construction of the building started in 1840 but, because of the famine, amongst other events, it was not completed until 1904 although it was dedicated in 1873. It is a traditional Gothic style building built largely of local limestone and is modelled in looks but not size, on York Minster in England. The interior is widely decorated and painted with fine paintings covering the walls and the ceiling. There are many mosaics and much of the interior is covered in marble. The second Vatican council in the 1960 required that the altar be moved forward into the nave and this resulted in a number of internal changes to the building. Many of the interior items such as the pulpit and the cathedra were gifts from various parts of the world. This is a busy cathedral which holds over 300 services per year and with over 90,000 people attending those services. The cathedral has a seating capacity of 850 and regularly has attendances of around 450 to 500 people at services. The last major refurbishment of the building was carried out in 2003 at a cost of some £6M. The cathedral has an integral shop which is in a separate room off the West end of the nave. It also has a pipe organ which was originally built by William Telford in 1875 and it was rebuilt in 1904 and in 1987-1989. (Official cathedral guide book, 2003). This is a cruciform cathedral with central nave and side aisles. The floor is tiled and the pews are wooden. The ceiling is highly decorated with a void between the ceiling and roof. The interior of the cathedral was substantially altered by the requirements of Vatican II.

Appendix 5.1A – floor plan with the loggers and TinyTag location

(A) SUMMER

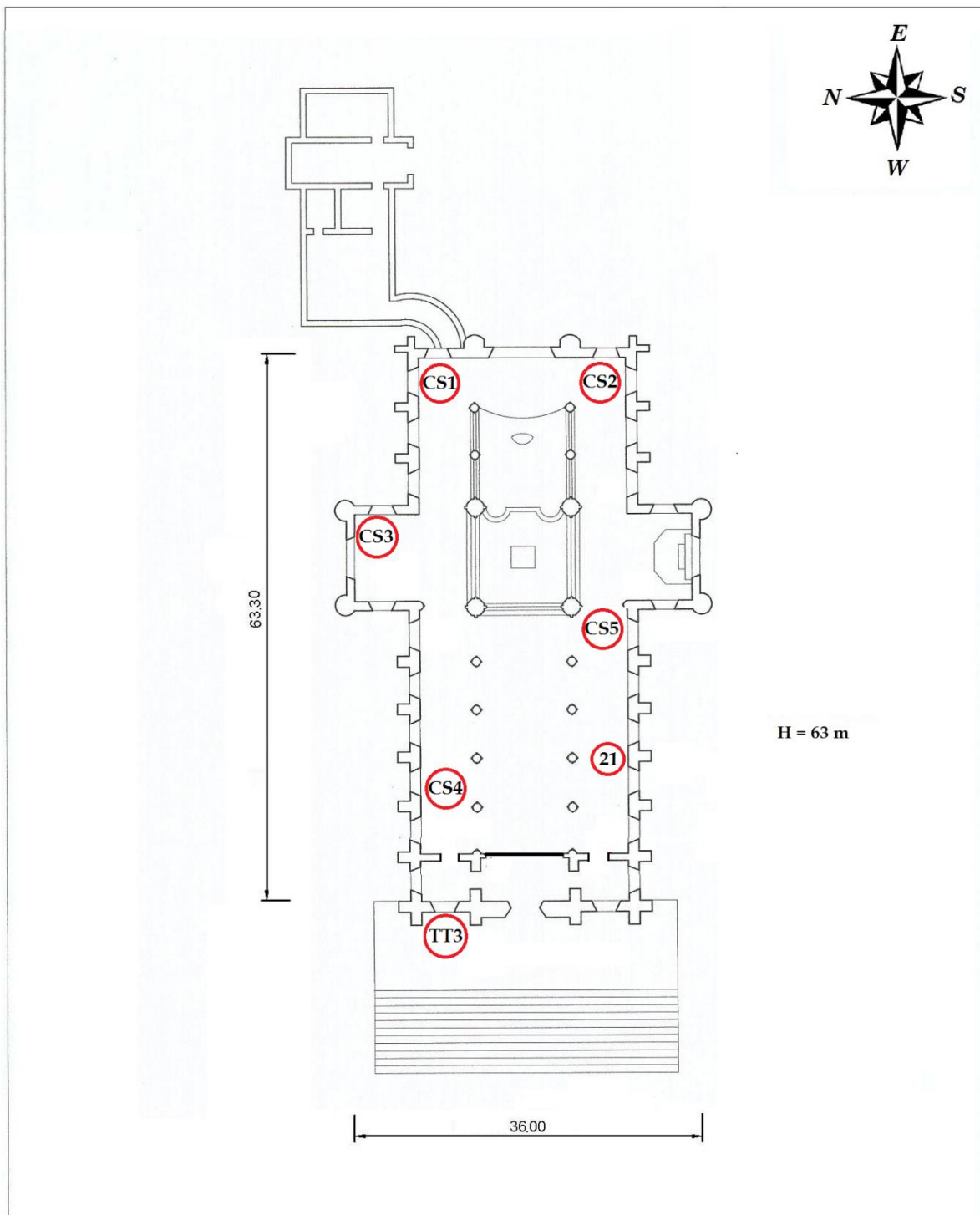

St. Patrick's Cathedral - Summer Armagh - Northern Ireland Roman Catholic Church	Size:	37,000 m ³
	Location:	54° 21' 8" N / 6° 39' 37" W
	Heating type:	LPHW

Appendix 5.2A – Loggers' graphs

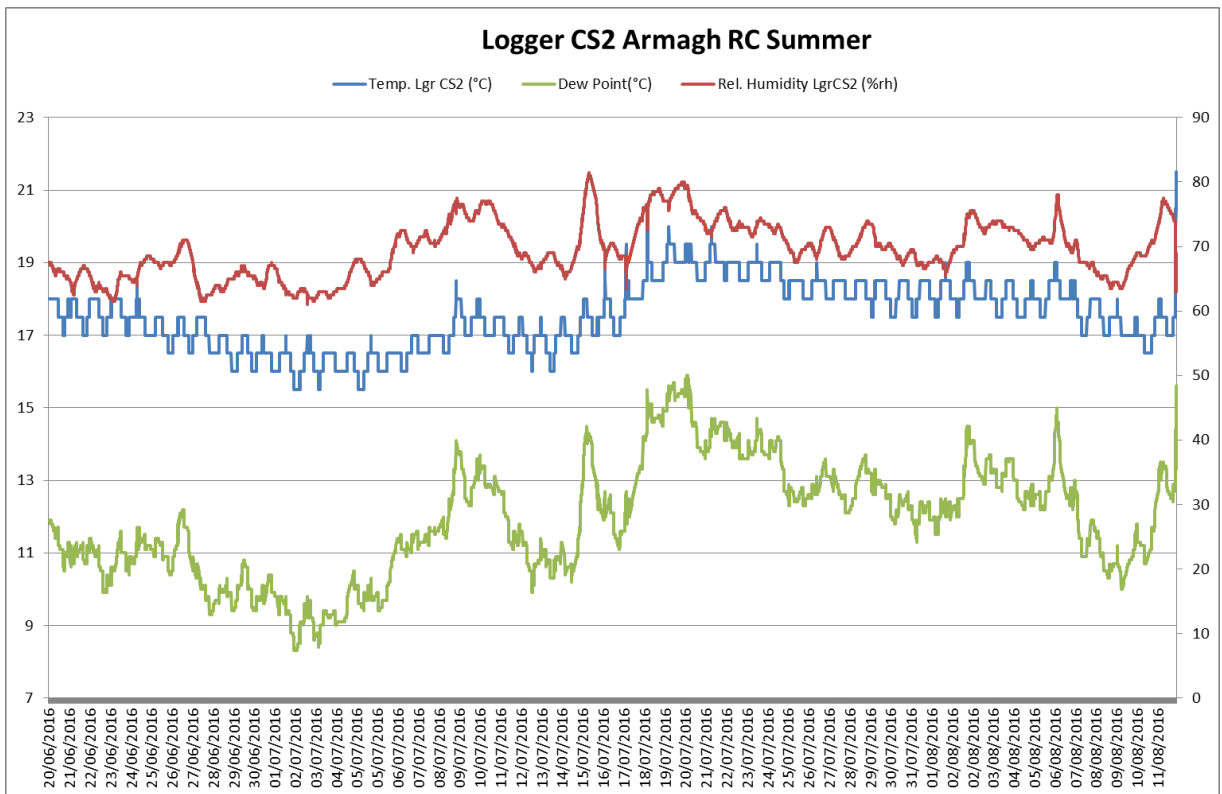
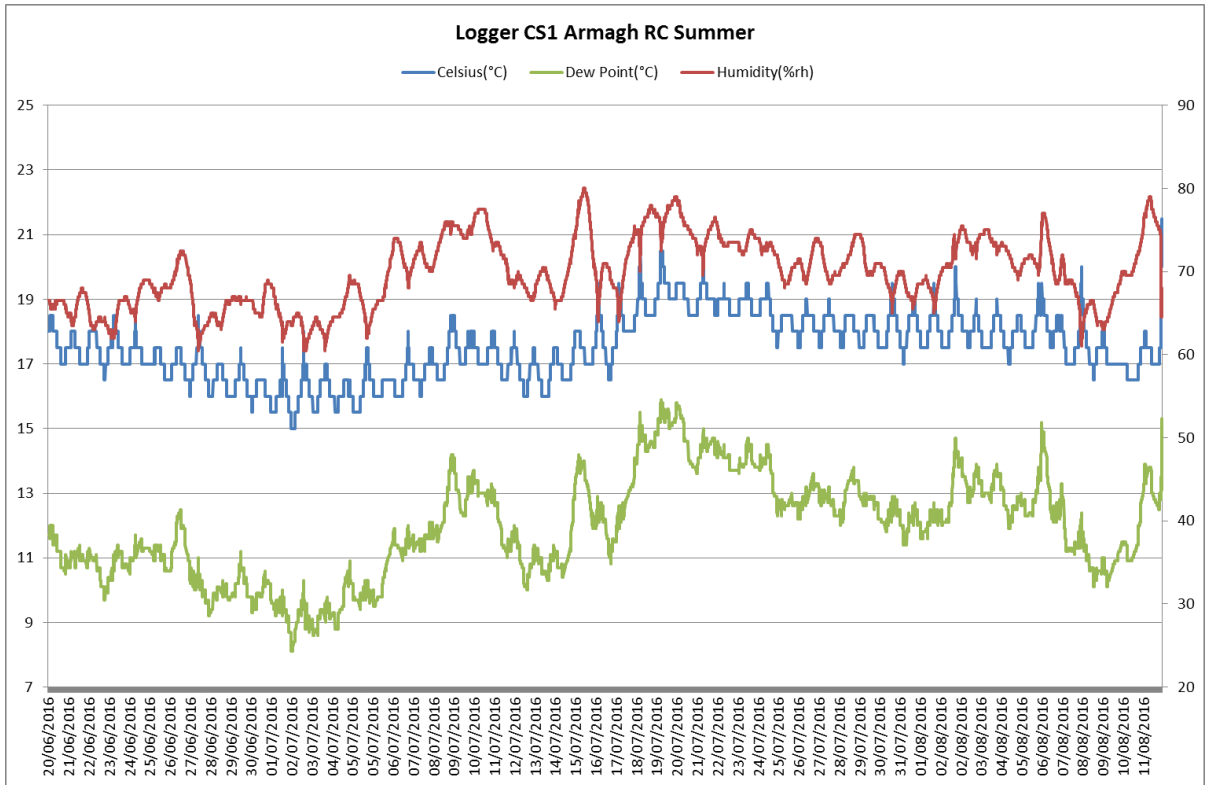

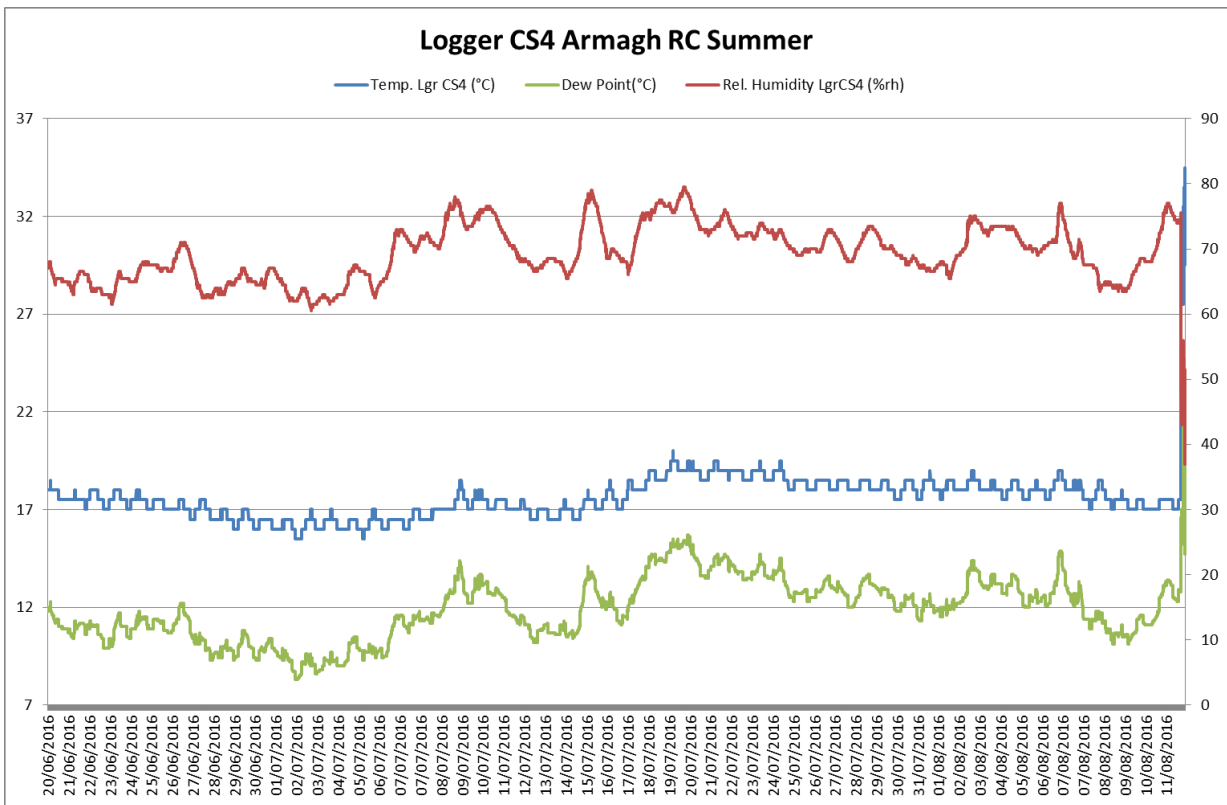
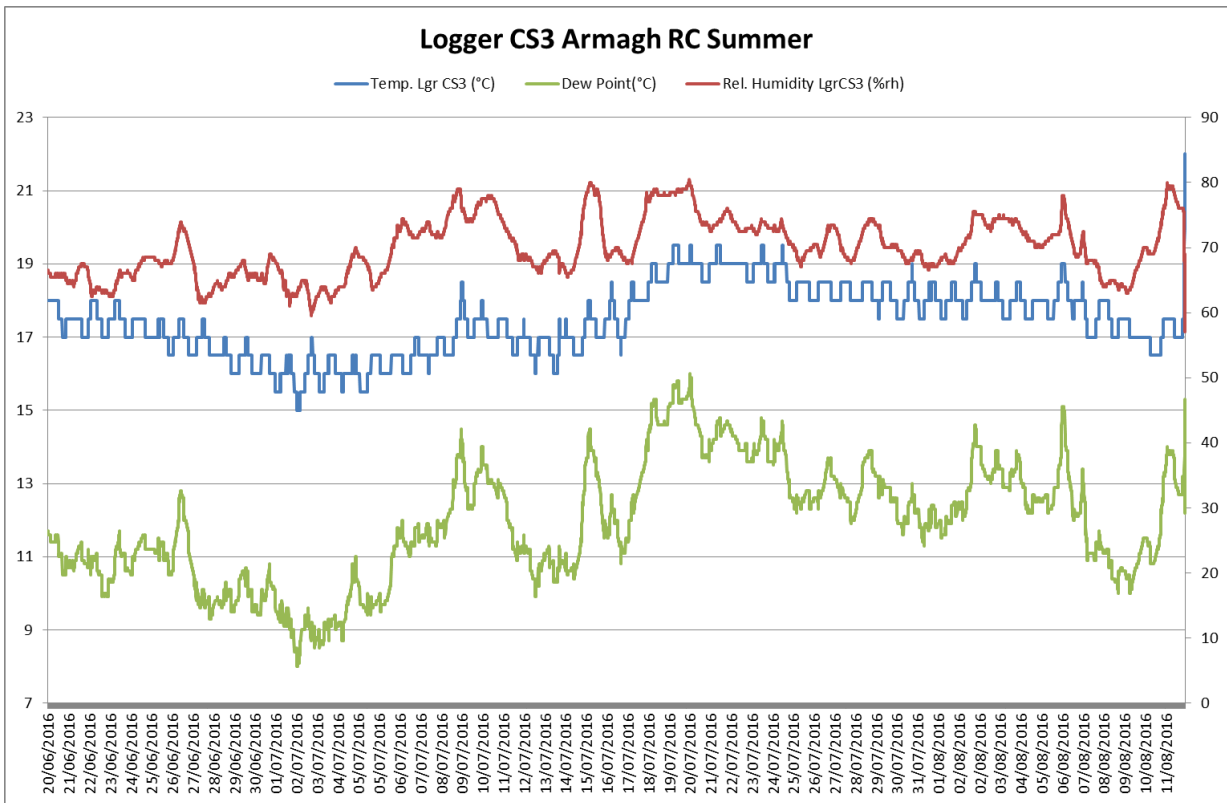

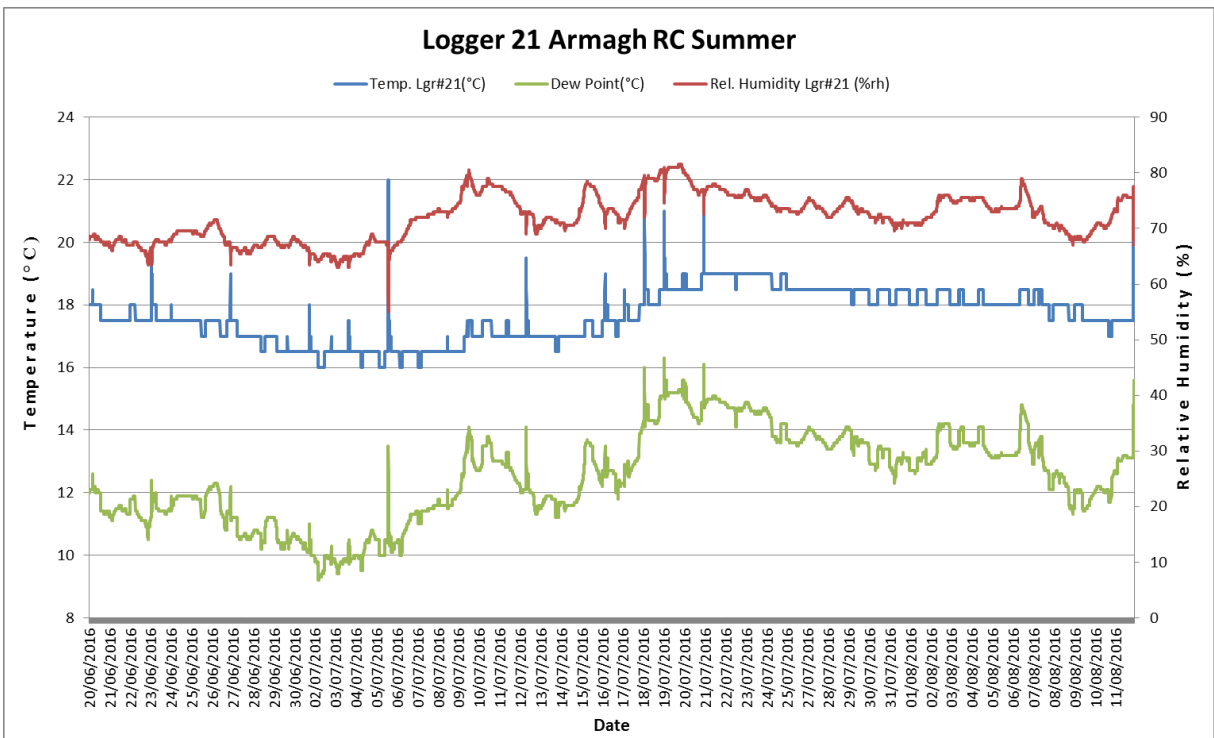
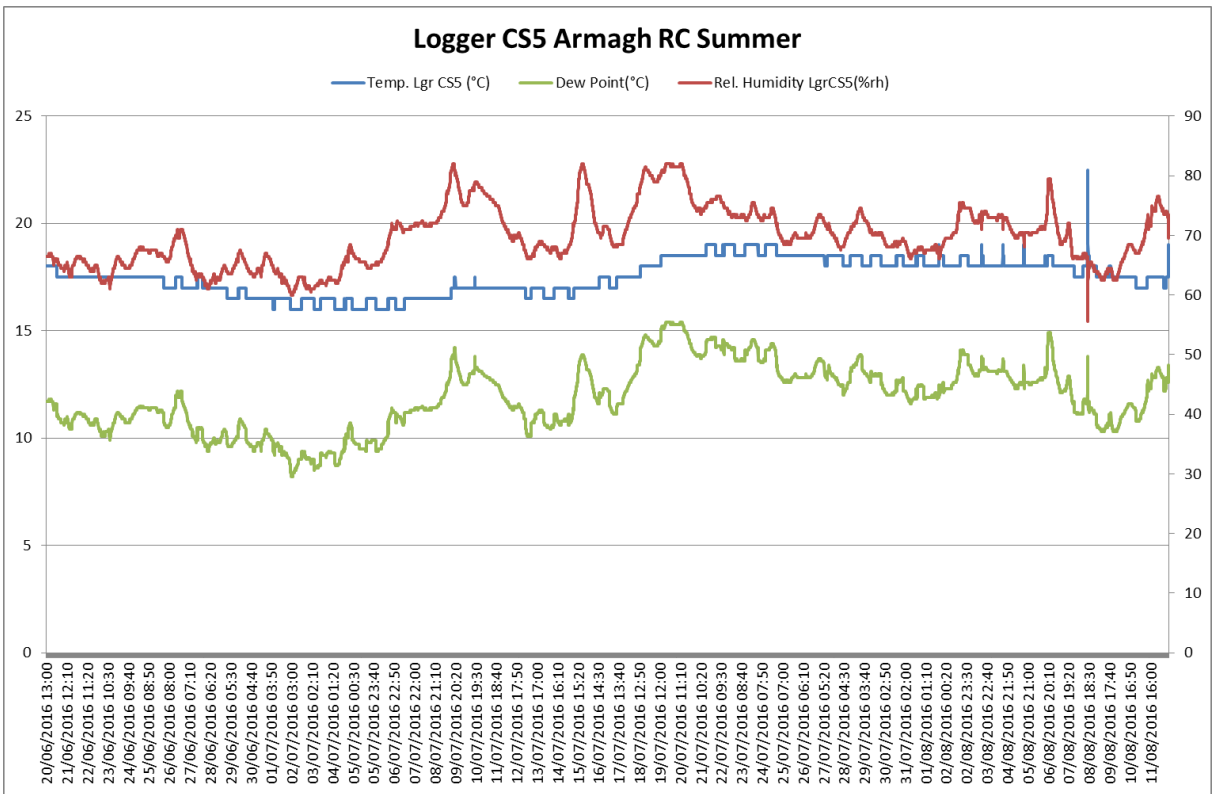

Appendix 5.3A – Tinytag graph

TT3 St. Armagh RC Summ

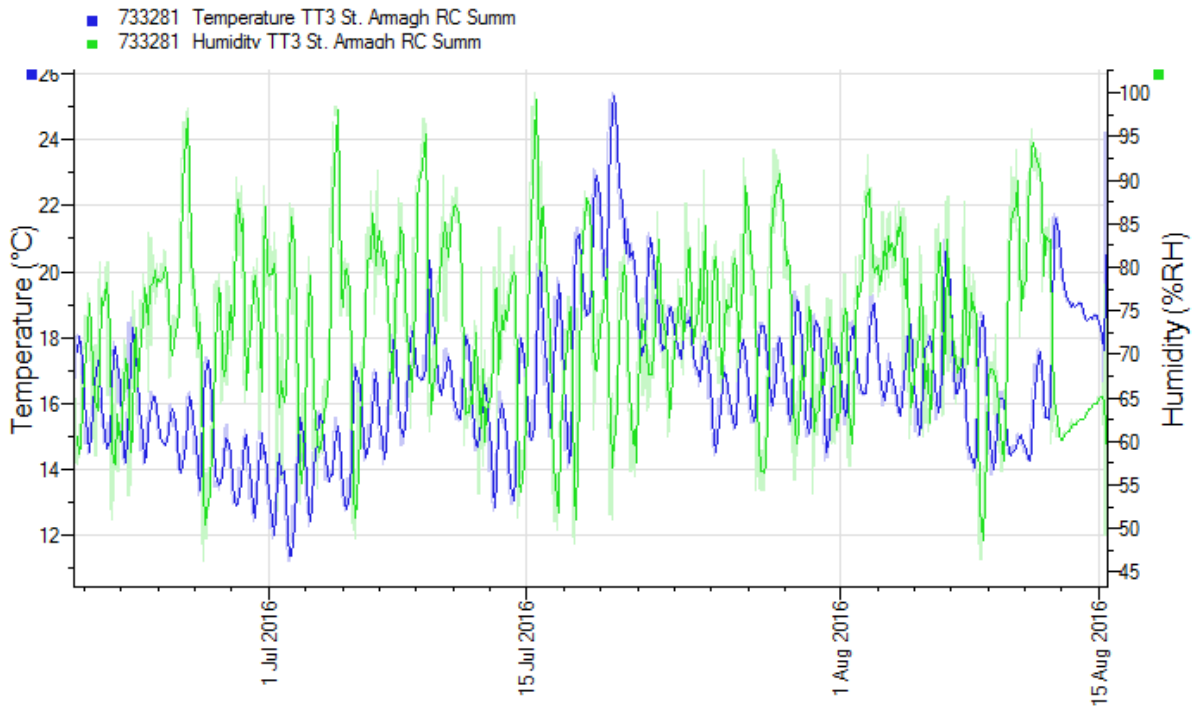

Appendix 5.1B – floor plan with the loggers and TinyTag location

(B) WINTER

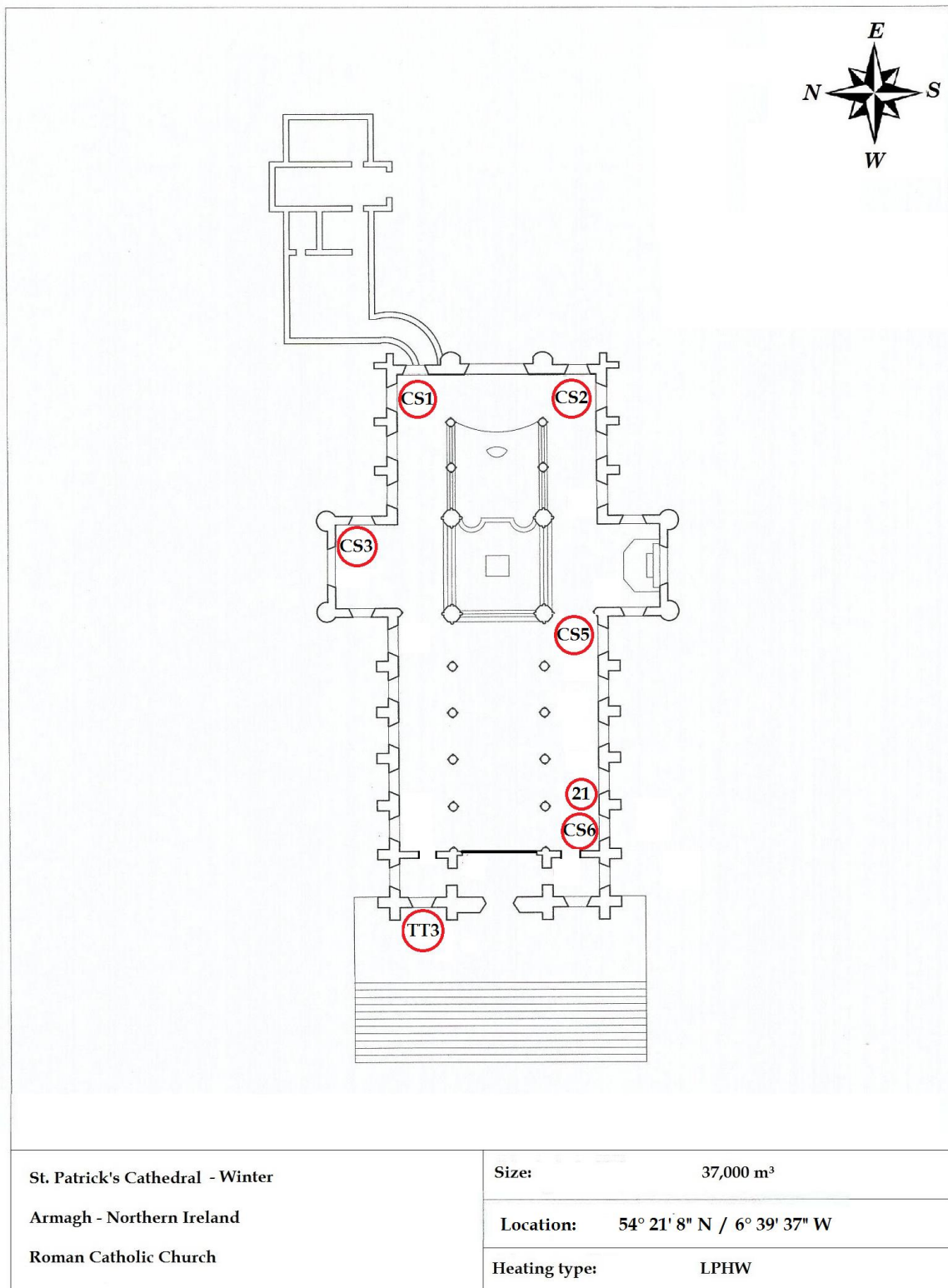

Appendix 5.2B – Loggers' graphs

Logger CS1 Armagh Winter

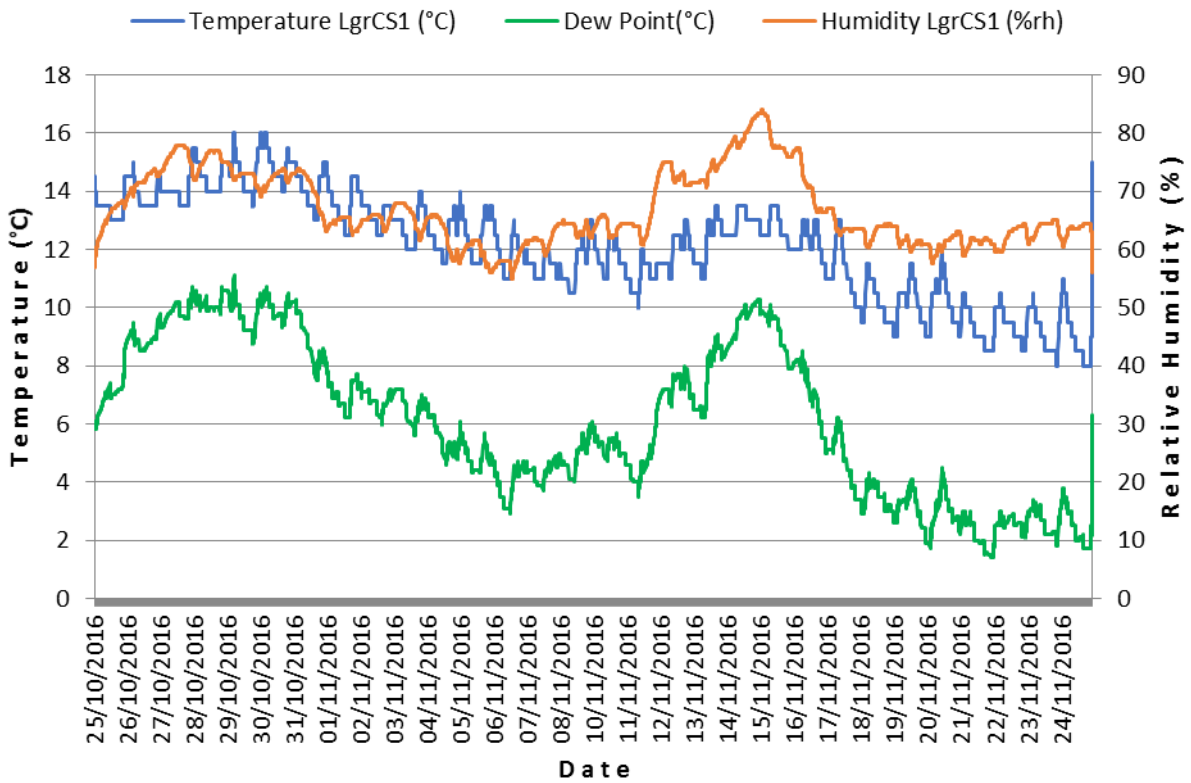

Logger CS2 Armagh Winter

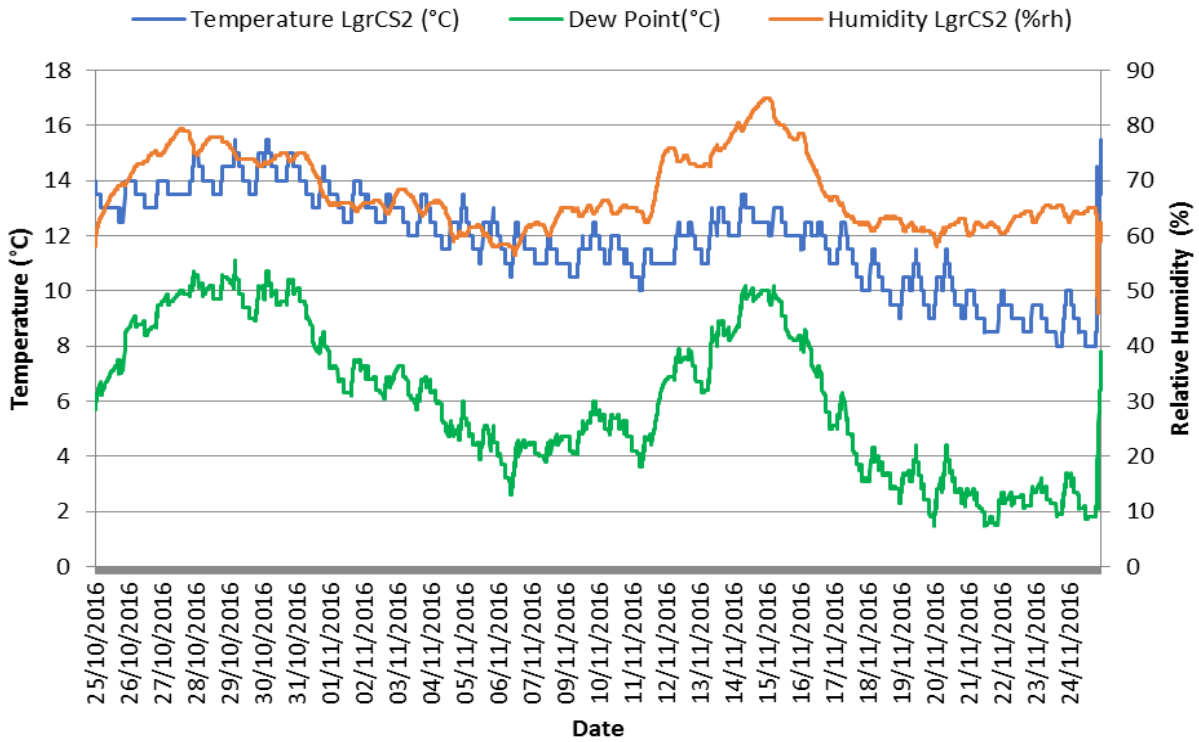

Logger CS3 Armagh Winter

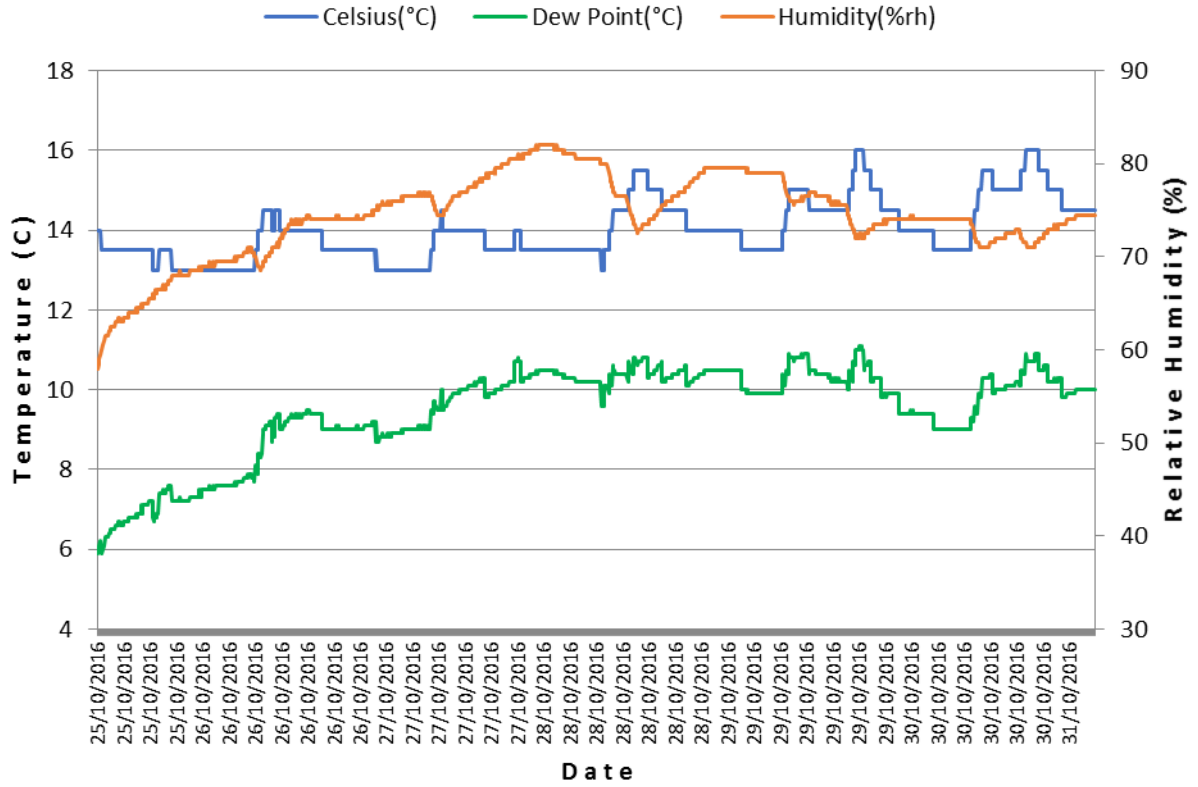

Logger CS5 Armagh Winter

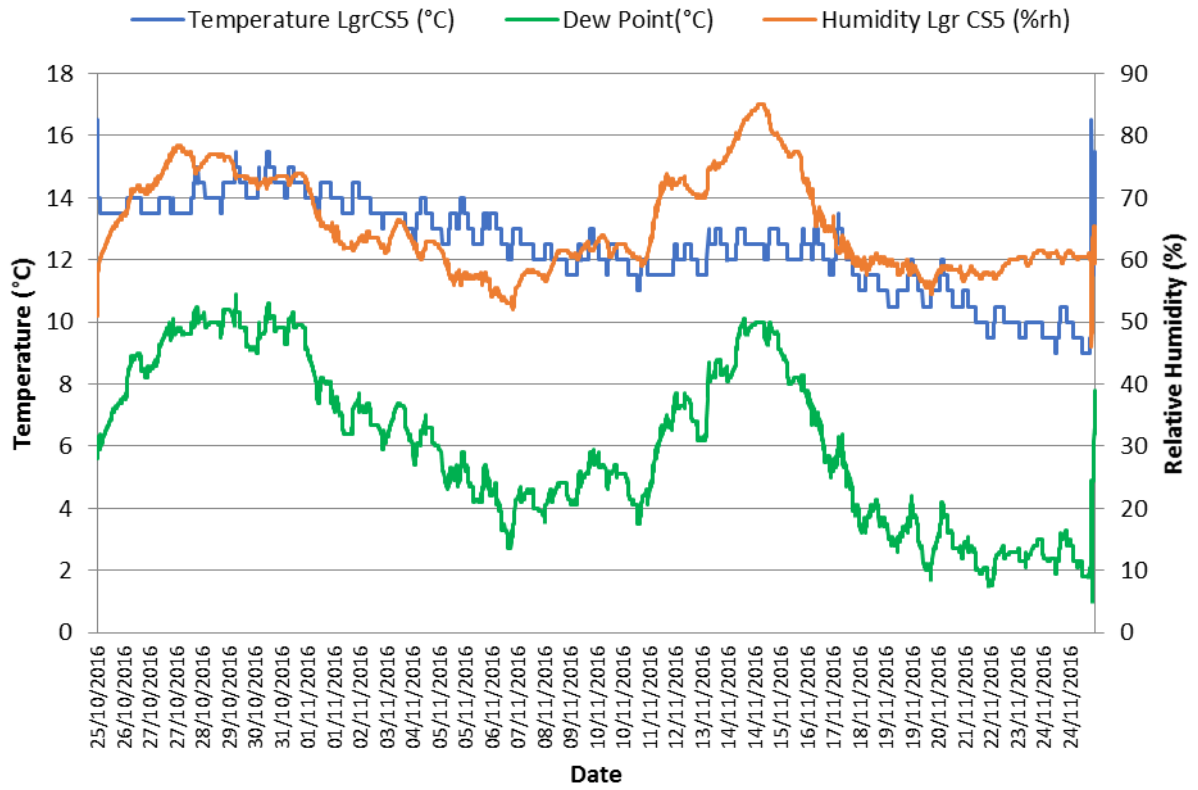

Logger CS6 Armagh Winter

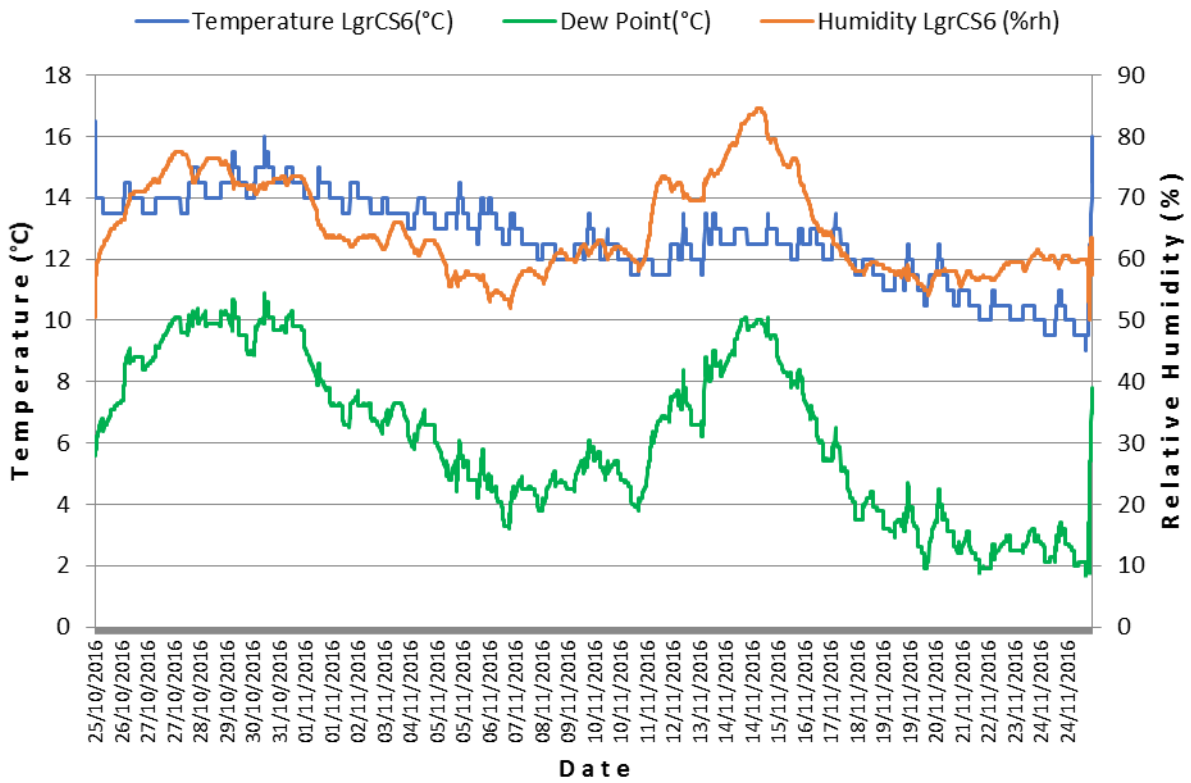

Logger 21 Armagh Winter

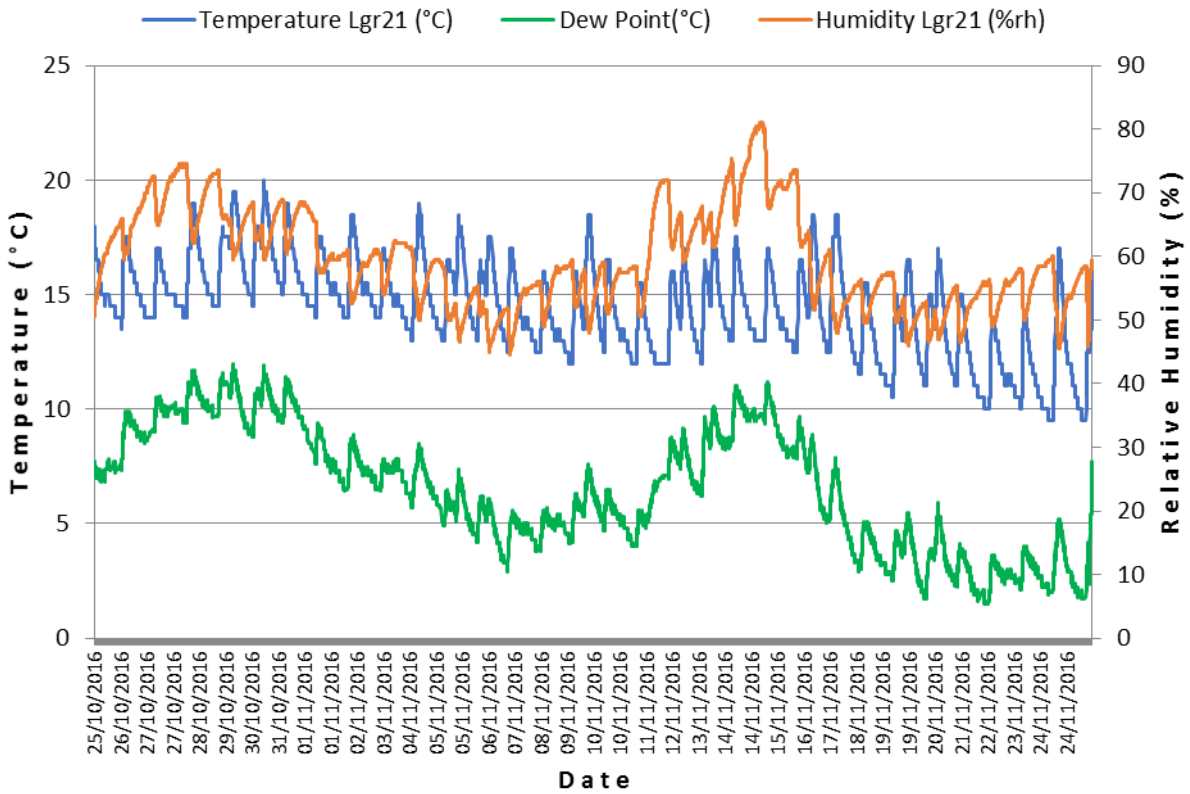

Appendix 5.3B – Tinytag graph

TT3 St. Armagh RC Wint

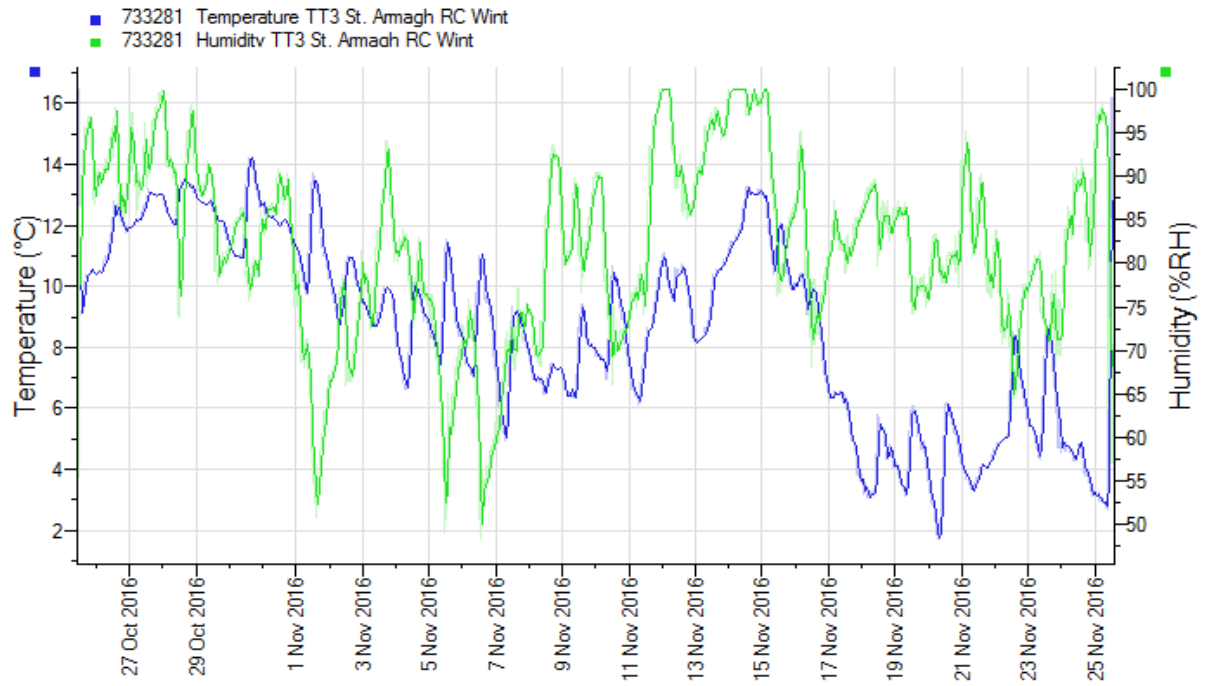

Appendix 6 – St. Mary’s Pro Cathedral, Roman Catholic



Photo by DAVID ILIFF. License: Creative Commons-BY-SA 3.0

Dublin

Name:	The Cathedral of the Immaculate Conception of the Blessed Virgin Mary.
Location:	Dublin City, Republic of Ireland.
Tradition:	Church of Ireland.
Outline history:	

It was originally intended that this cathedral would be built on the site of the present general post office which is situated in O’Connell Street in Dublin. This street used to be called Sackville Street. However it was decided that building a Roman Catholic cathedral in such a prominent location was too bold a step and it was felt by the RC hierarchy that such a step might set back the implementation of Catholic Emancipation and so a less prominent site was chosen in Marlborough Street just off what was then called Sackville Street. The architect of the cathedral is unknown but may have been a Frenchman called Louis leBas because he also built a church in Notre Dame in Paris which is very similar in design to the Pro cathedral. leBas was Napoleon’s architect and as Britain was at war with France at the time, it would have been important to keep his name secret. The cathedral has been altered and added to many times since it was dedicated on November 14, 1825 with a large expansion being made in 1928 when the cathedral was widened, on both sides, to maximise the seating capacity. In the 1920s extensive roof repairs were required as a result of damage caused by pollution. Over the years the cathedral has been the site of many important public and liturgical events in the life of the city of Dublin and Ireland. This cathedral is almost as wide as it is long and although there are pillars down each side of the nave there are no side aisles, as such. The floor is tiles and the pews are wooden. The ceiling is wooden and plastered and the windows both plain and stained glass are single glazed.

Appendix 6.1 – Floor plan with loggers and TinyTag location

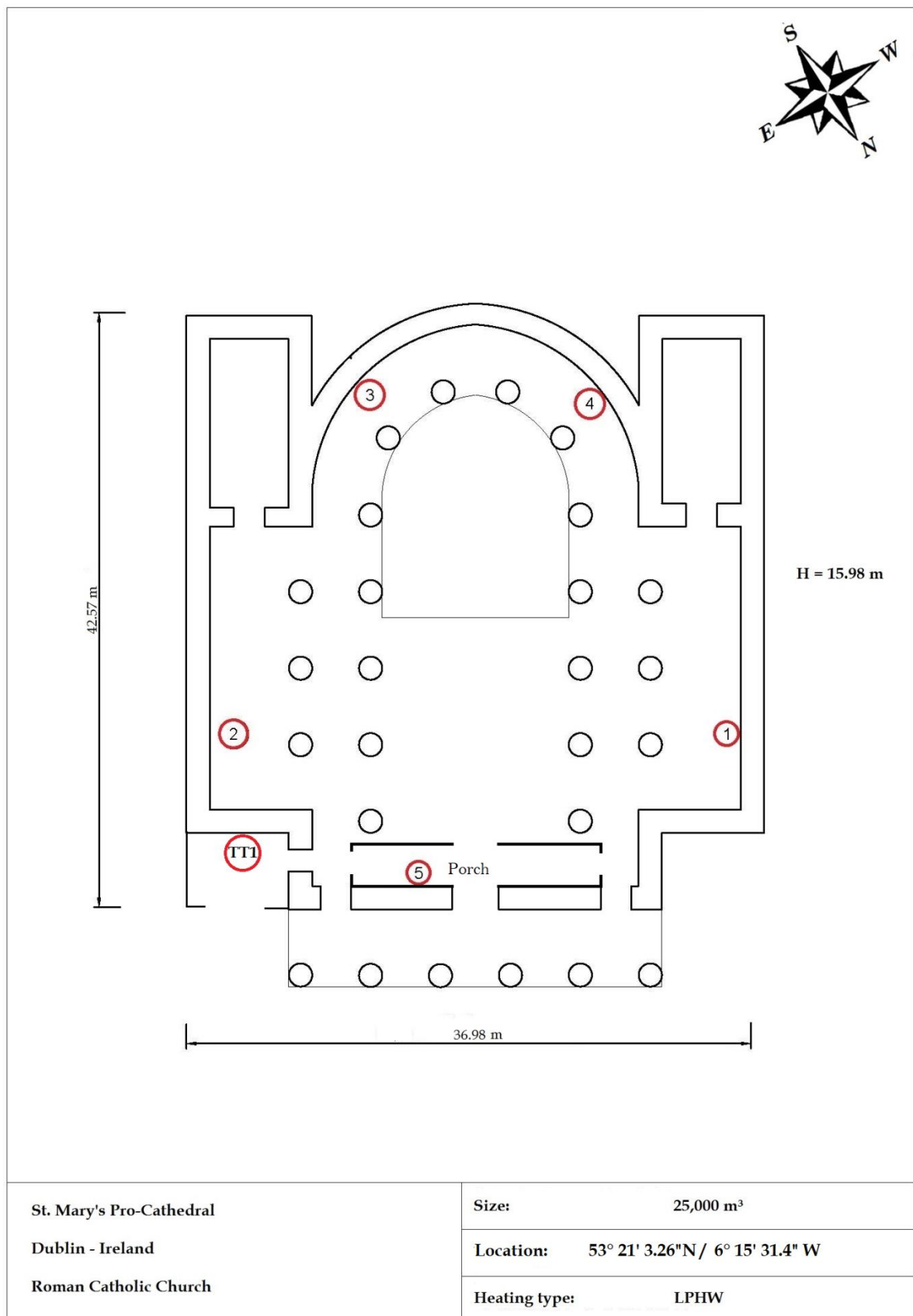

Appendix 6.2 – Loggers’ graphs

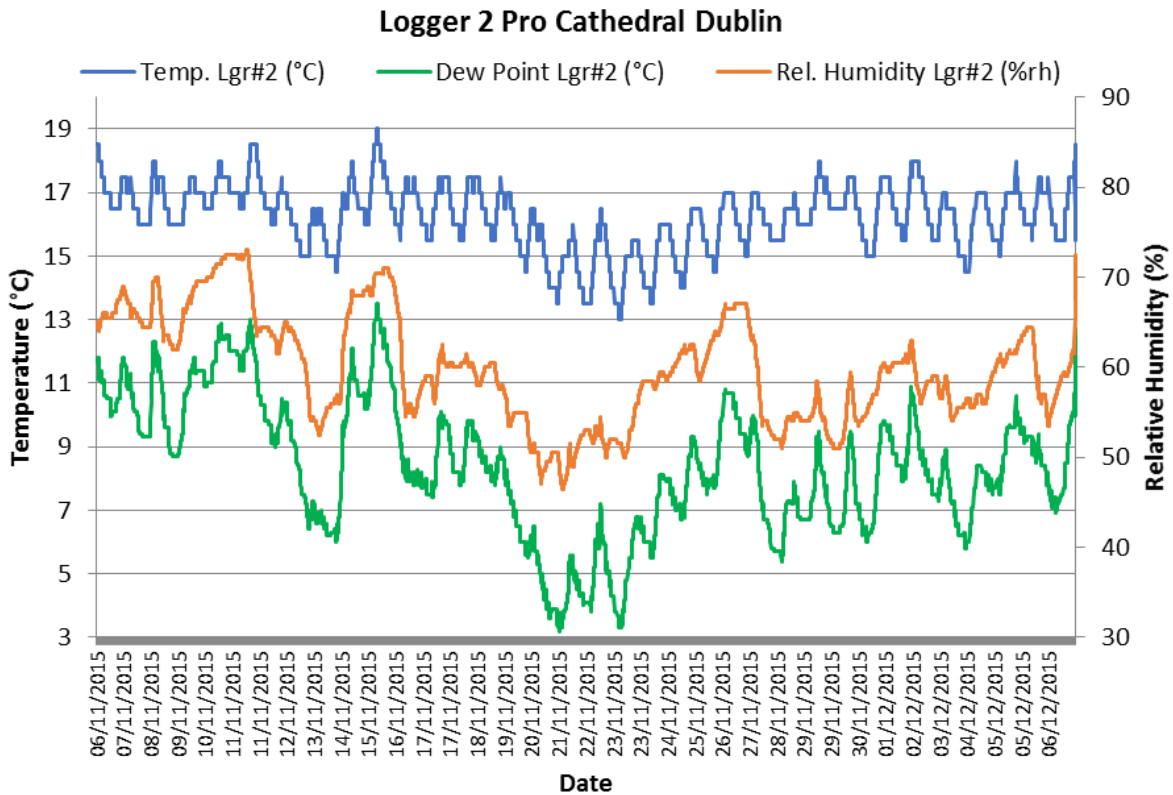
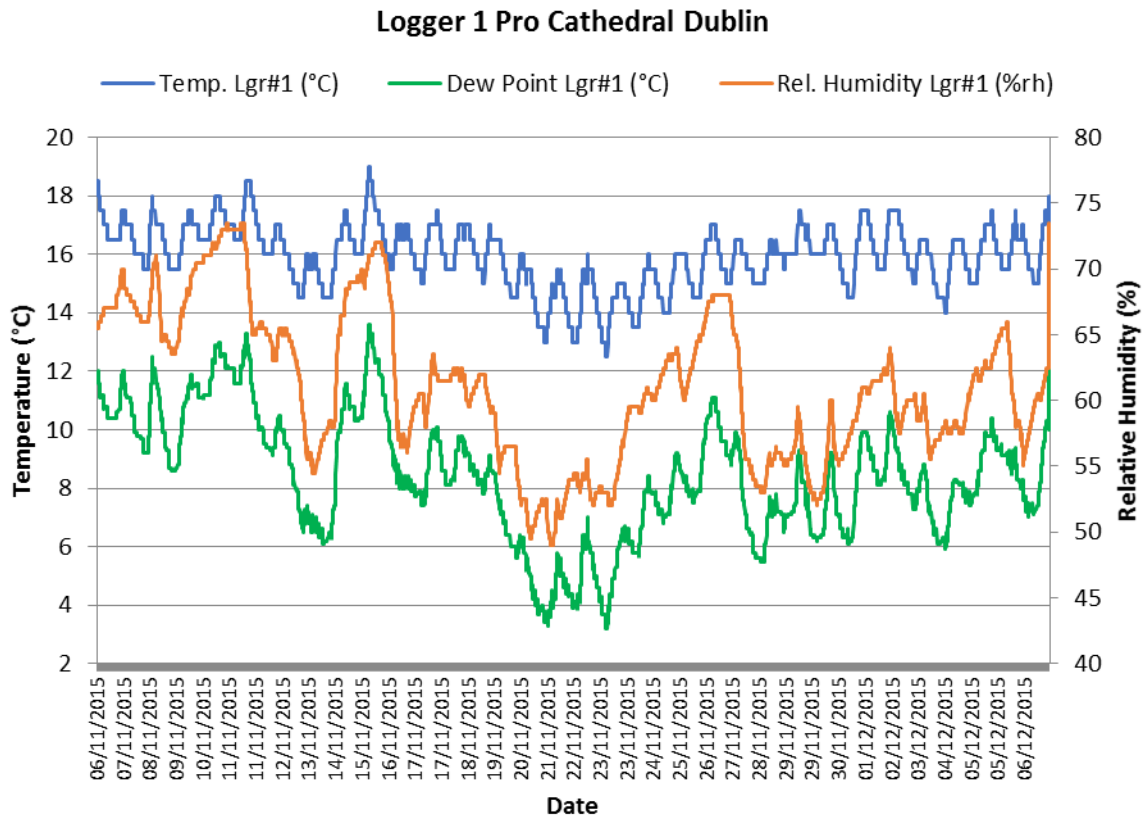

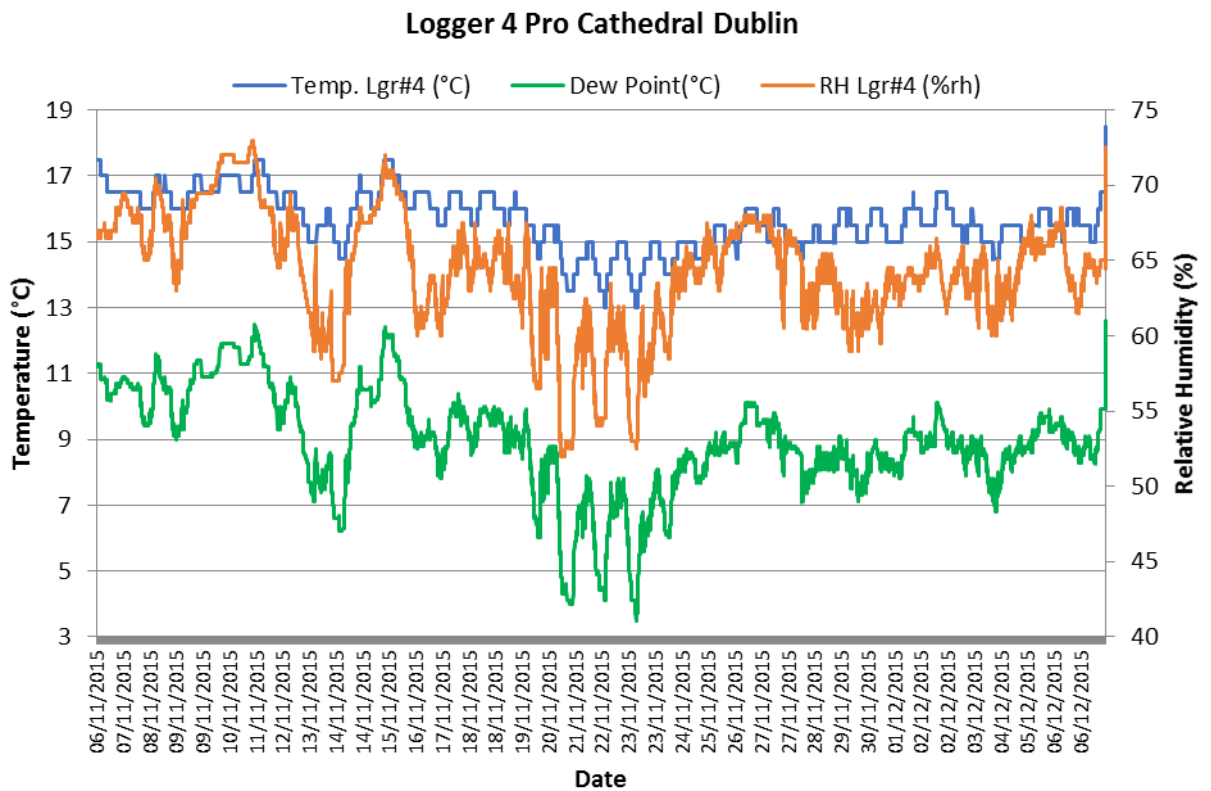
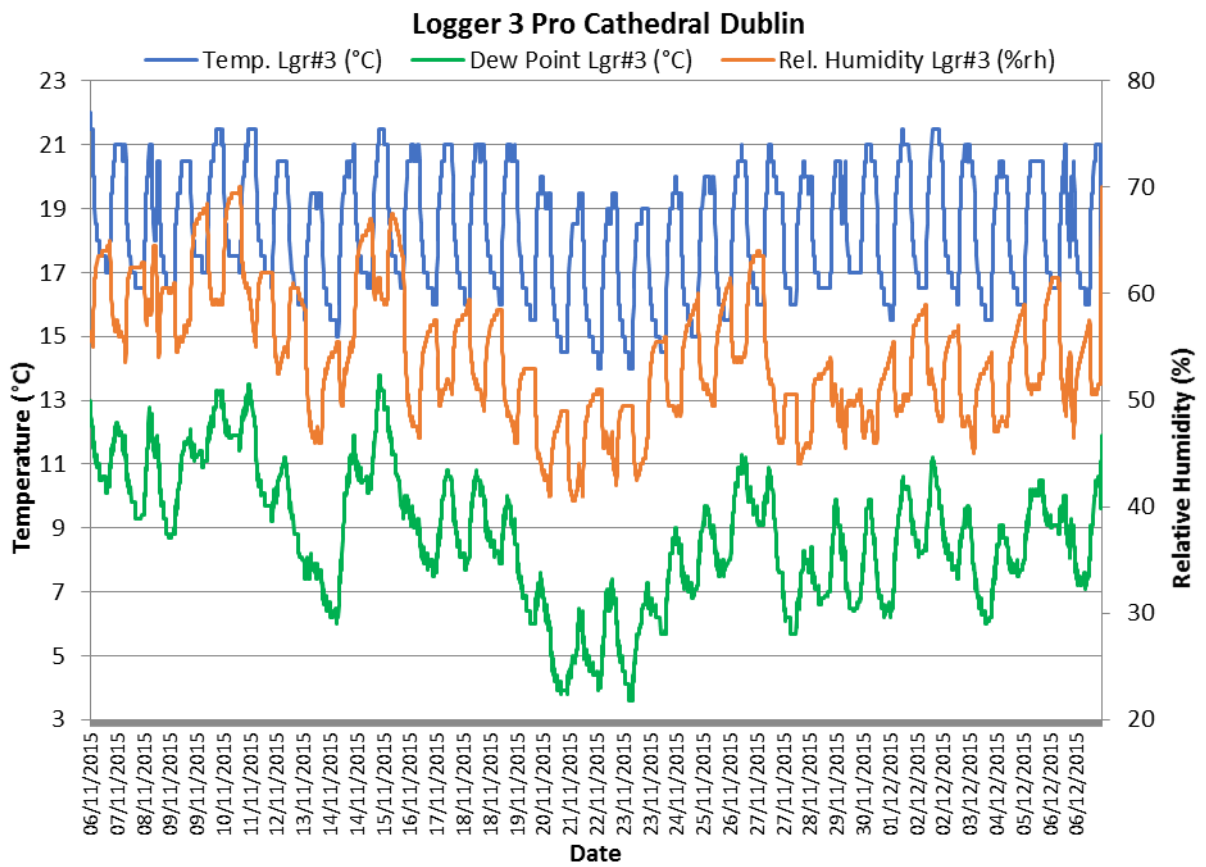

Logger 5 Pro Cathedral Dublin

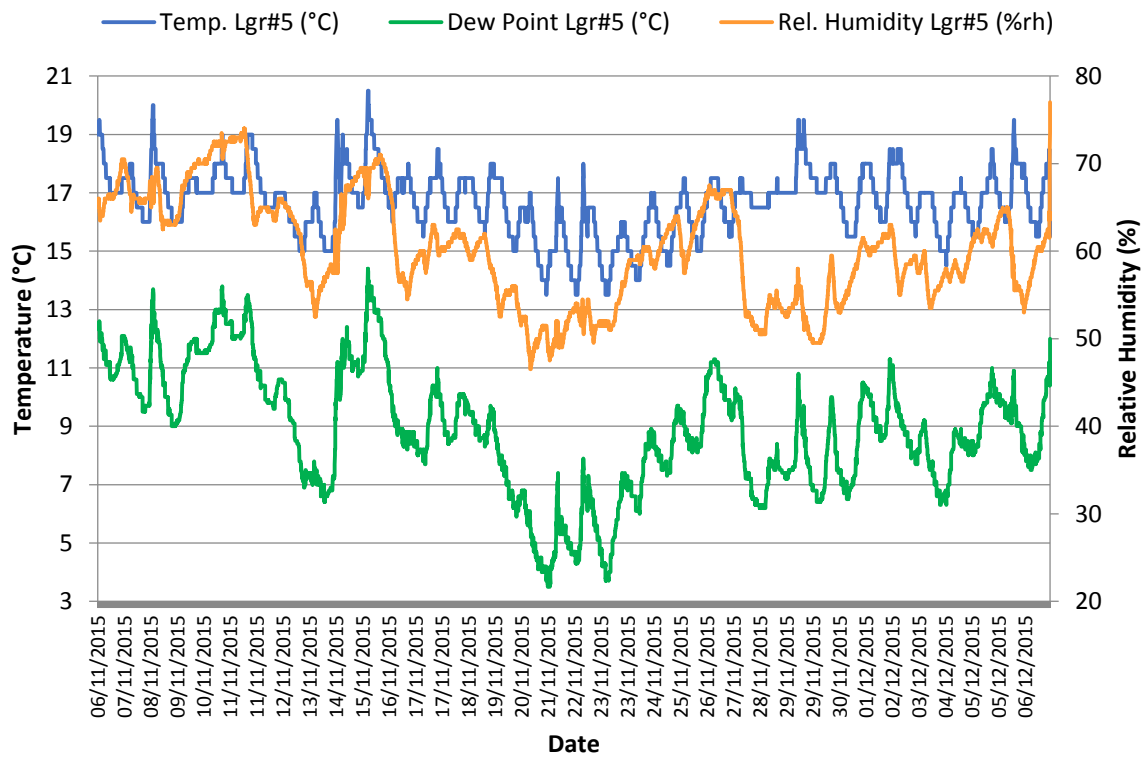

Appendix 6.3 – Tinytag graph (outside T and RH)

TT2 St. Pats Dub02/15

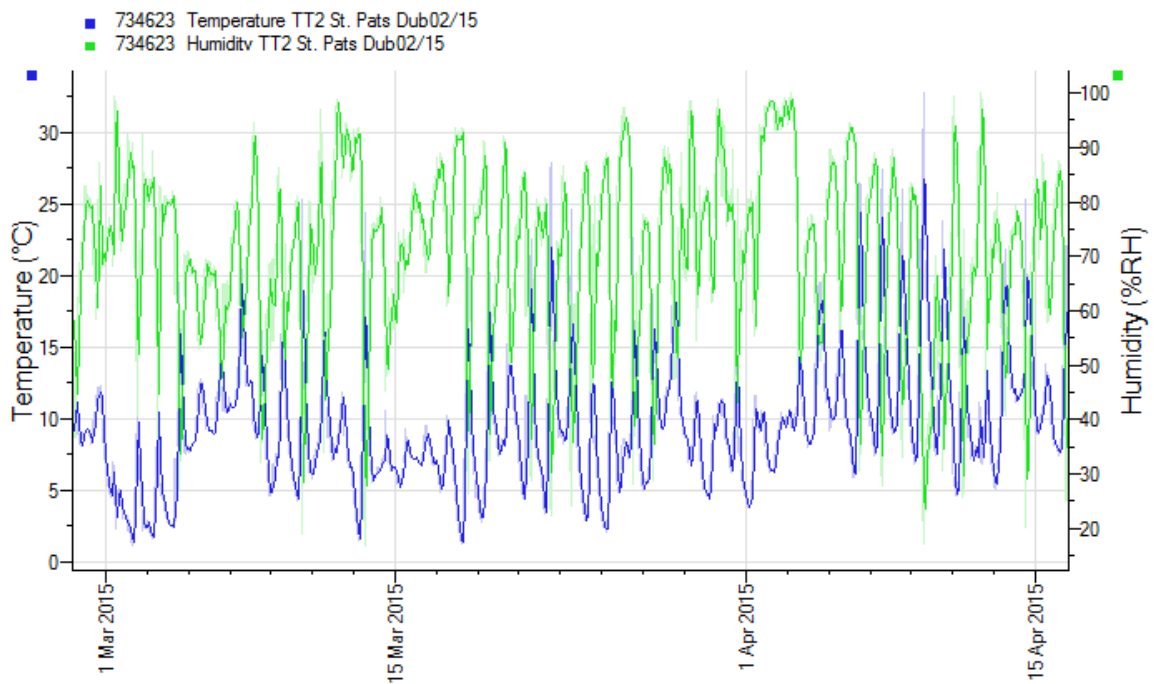

Appendix 7 – St. Mary’s Church of Ireland Cathedral



Limerick

Name: The Cathedral Church of St. Mary.

Location: Limerick City, Republic of Ireland.

Tradition: Church of Ireland.

Outline history: St. Mary's cathedral was originally built between 1168 and 1207 and has been added to and restored many times over the centuries. The cathedral is situated in the heart of Limerick city right on the banks of the River Shannon and on the original site of the palace of the Kings of Munster. The building suffered greatly under Cromwell in the mid-1600s and required major restoration work as a result. Another major restoration took place in the mid-1800s in an attempt to restore the original Gothic features but this did not appear to meet with universal approval. In 1990 another major restoration took place which cost over €2.5m and which, amongst other things, involved the removal of all of the internal plaster work. Because of the many restorations and alterations which have been made to the building it is not possible to attribute a particular architectural style to the building. A new underfloor heating system was installed under the stone flags in the nave, in recent years. The building is unusual in having large stone flags on the floor and an underfloor heating system. The building as has been added to many time over the centuries but is is cruciform in shape the transepts having been added in the 13th century with a number of chapels being added later.. The cathedral has wooden seats rather than pews and these are covered in cloth which will absorb some of the moisture and sound. There are a number of wooden artifacts within the building.

Appendix 7.1 – Floor plan with loggers and TinyTag location

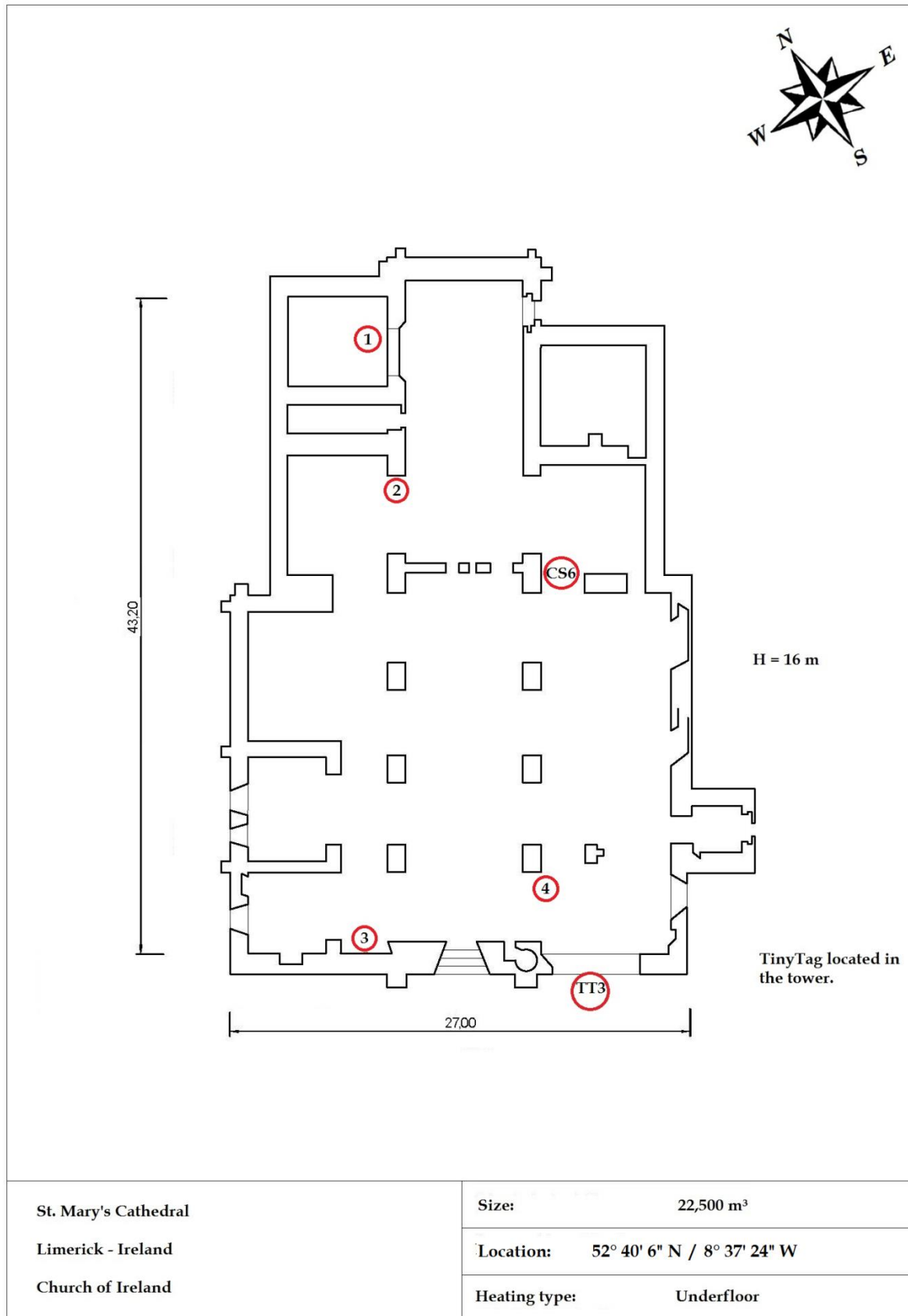

Appendix 7.2 – Loggers' graphs

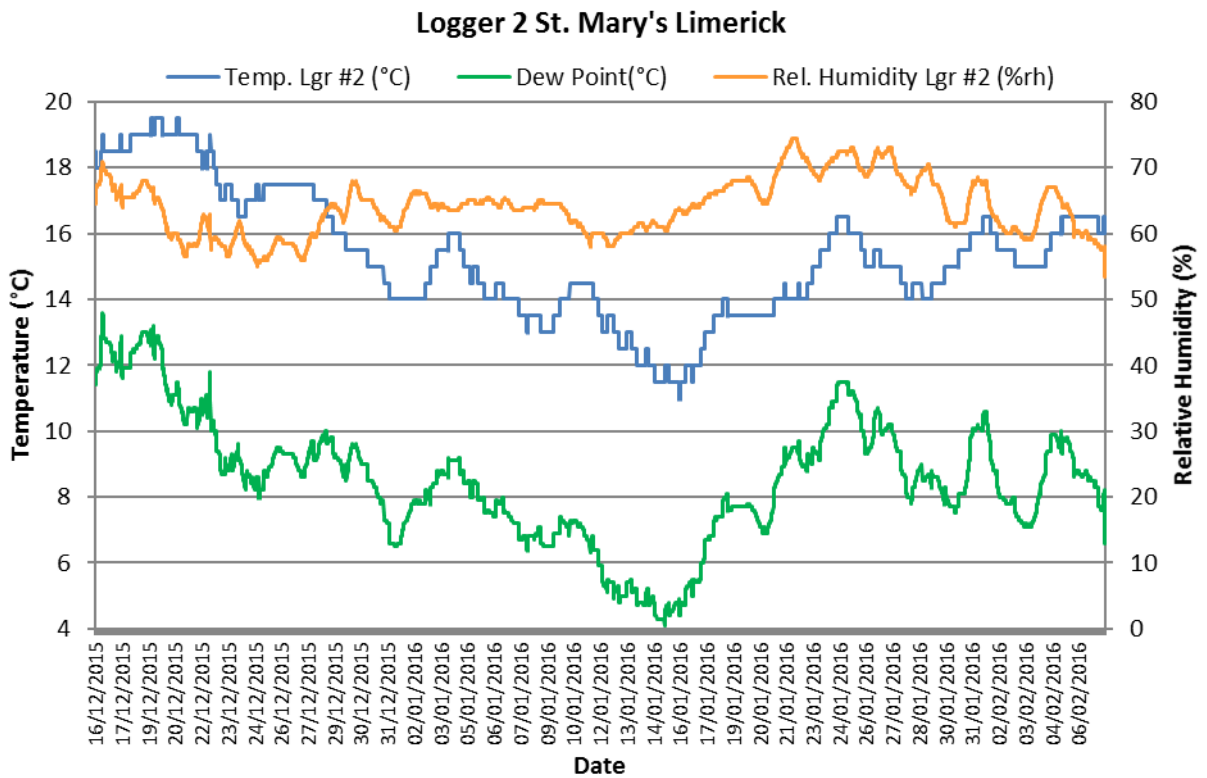
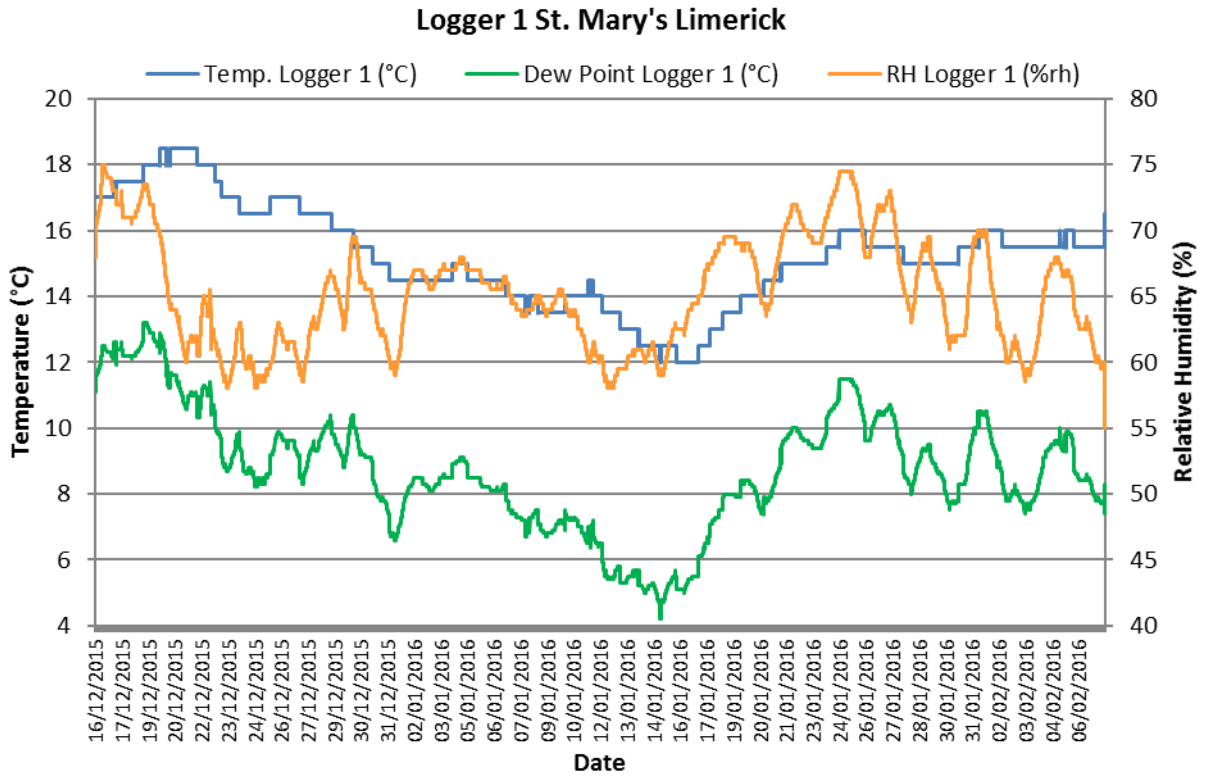

Logger 3 St. Mary's Limerick

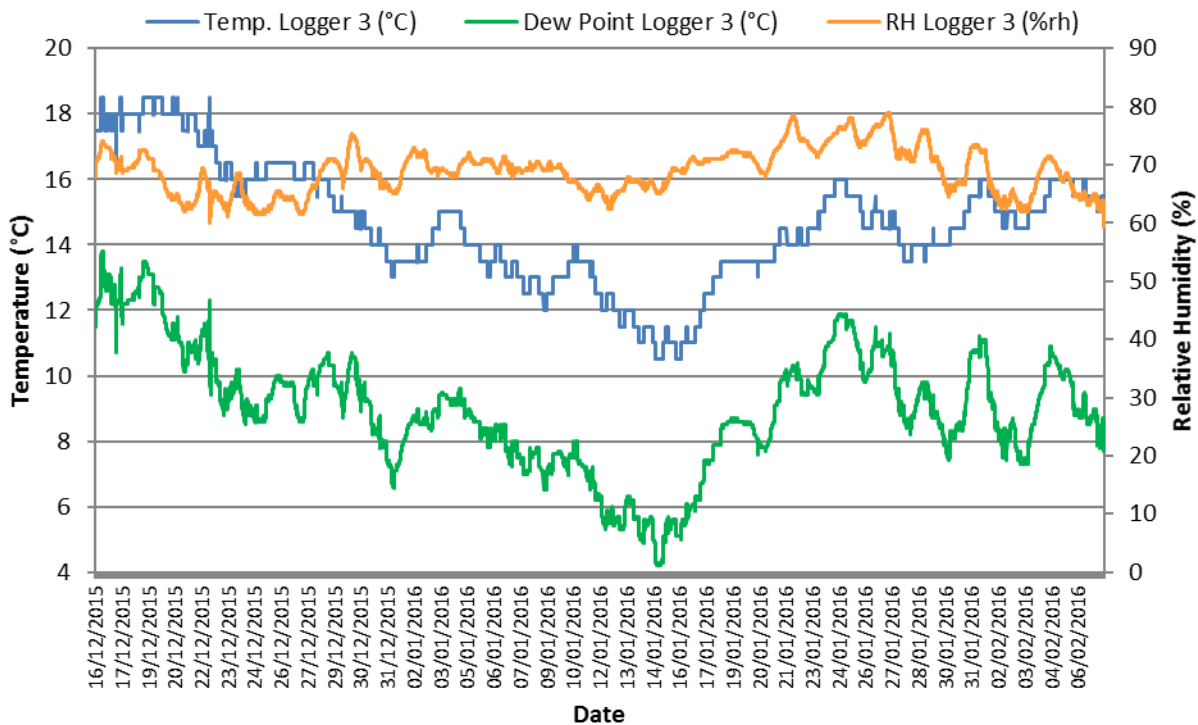

Logger 4 St. Mary's Limerick

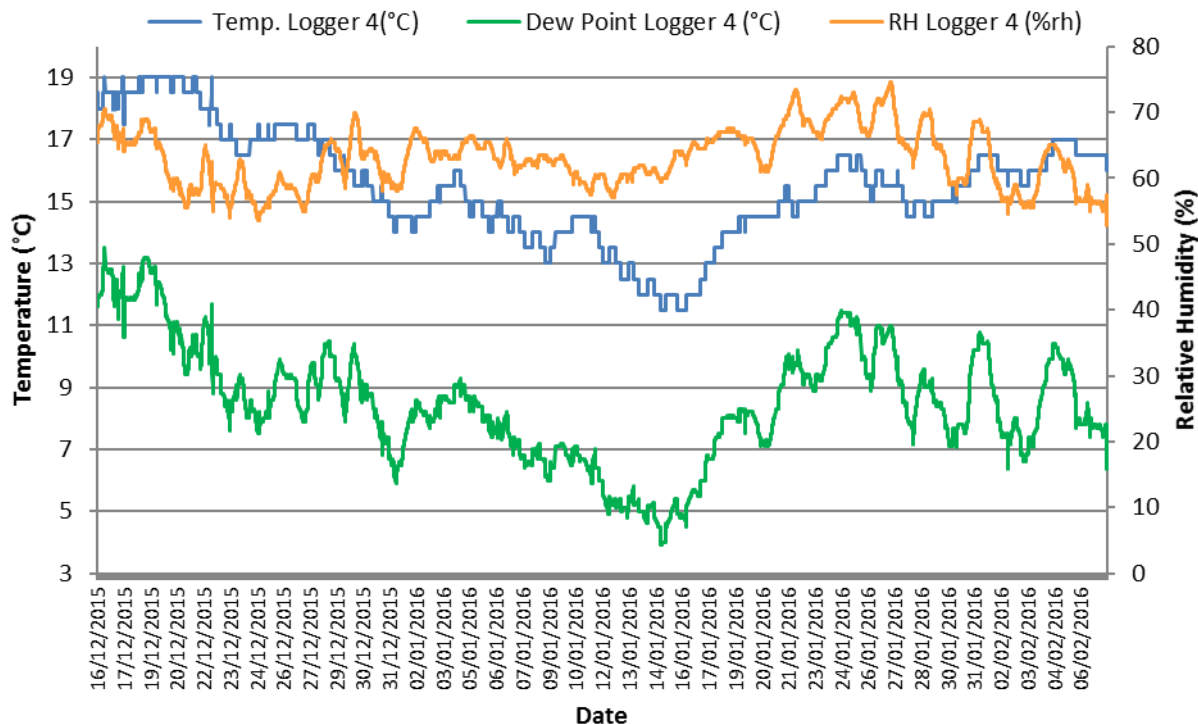

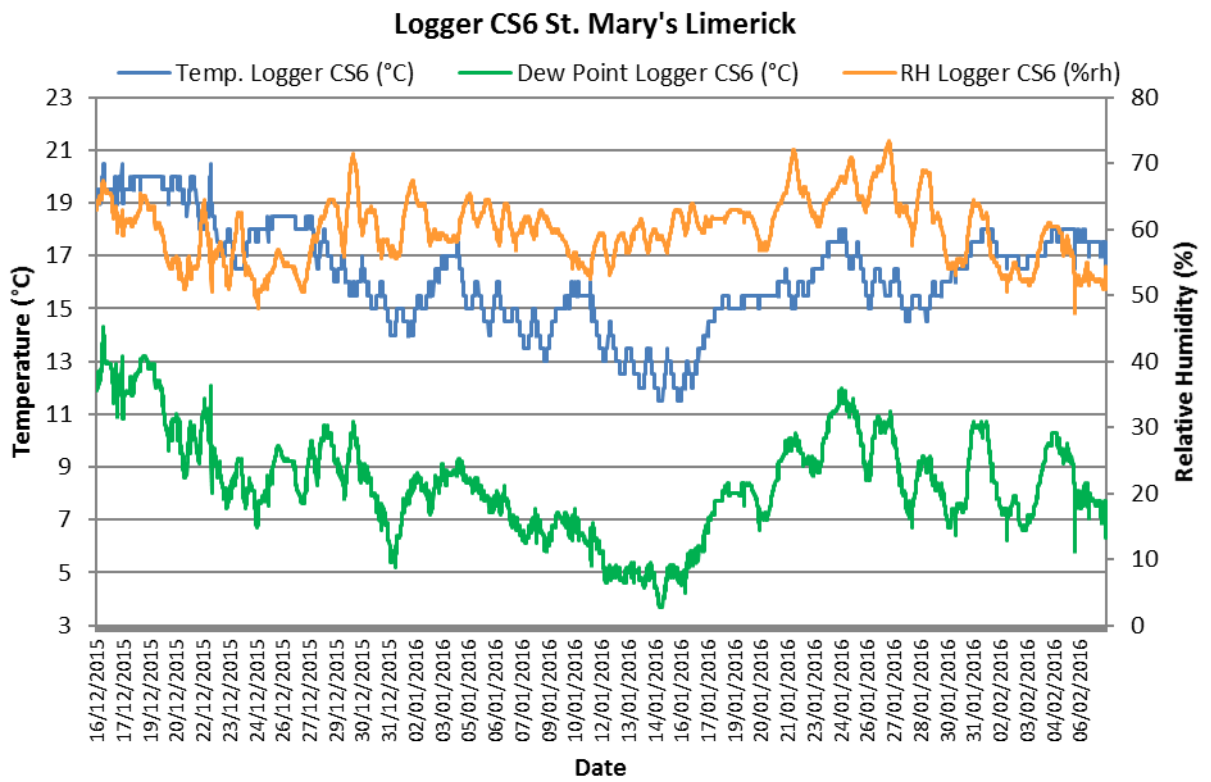

Appendix 7.3 – Tinytag graph (outside T and RH)

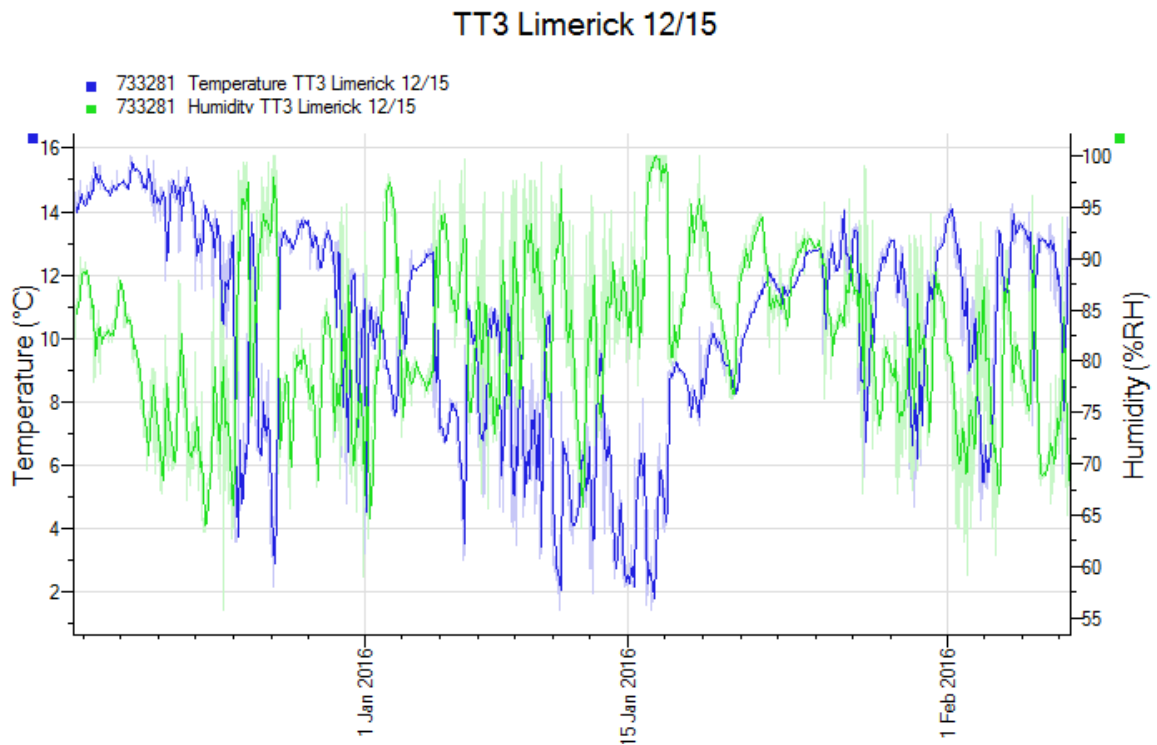

Appendix 8 – Saint Mary’s Roman Catholic Cathedral



Killarney

Name: The cathedral Church of The Assumption of the Blessed Virgin Mary.

Location: Killarney City, Republic of Ireland.

Tradition: Roman Catholic.

Outline history: St. Mary's cathedral as it is commonly known, in Killarney, occupies a very prominent position on flat land on the outskirts of the town and on land originally donated by the Presentation Brothers. The original building has been described as Gothic Revival in style and was designed by the famous architect Augustus Pugin (1812-52) who designed some 60 churches during his lifetime. The building work commenced in 1842 but work stopped during the famine years of 1846 and 1847 with the building finally being dedicated in 1855. The cathedral was very substantially restored and rearranged, particularly internally in the mid-1970s partly as a result of the Second Vatican Council but also because Pugin's original design was deemed to be less relevant for the type of liturgy which was then taking place in the cathedral. One of the biggest changes came with the complete removal of all of the internal plaster work in the cathedral which exposed the original stonework. This has changed the look and feel of the inside of the cathedral. Beneath the Lady Chapel, now known as the Kenmare chapel, is the burial place of the Earls of Kenmare.

The building is cruciform in shape with pillars separating the nave from the side aisles. The nave is particularly high which may lead to complex air flows. All of the internal plaster work on the walls was removed in the 1970's. The building has a tiles floor, single glazed stained glass windows and a considerable amount of wood, such as pews.

Appendix 8.1 – Floor plan with loggers and TinyTag location

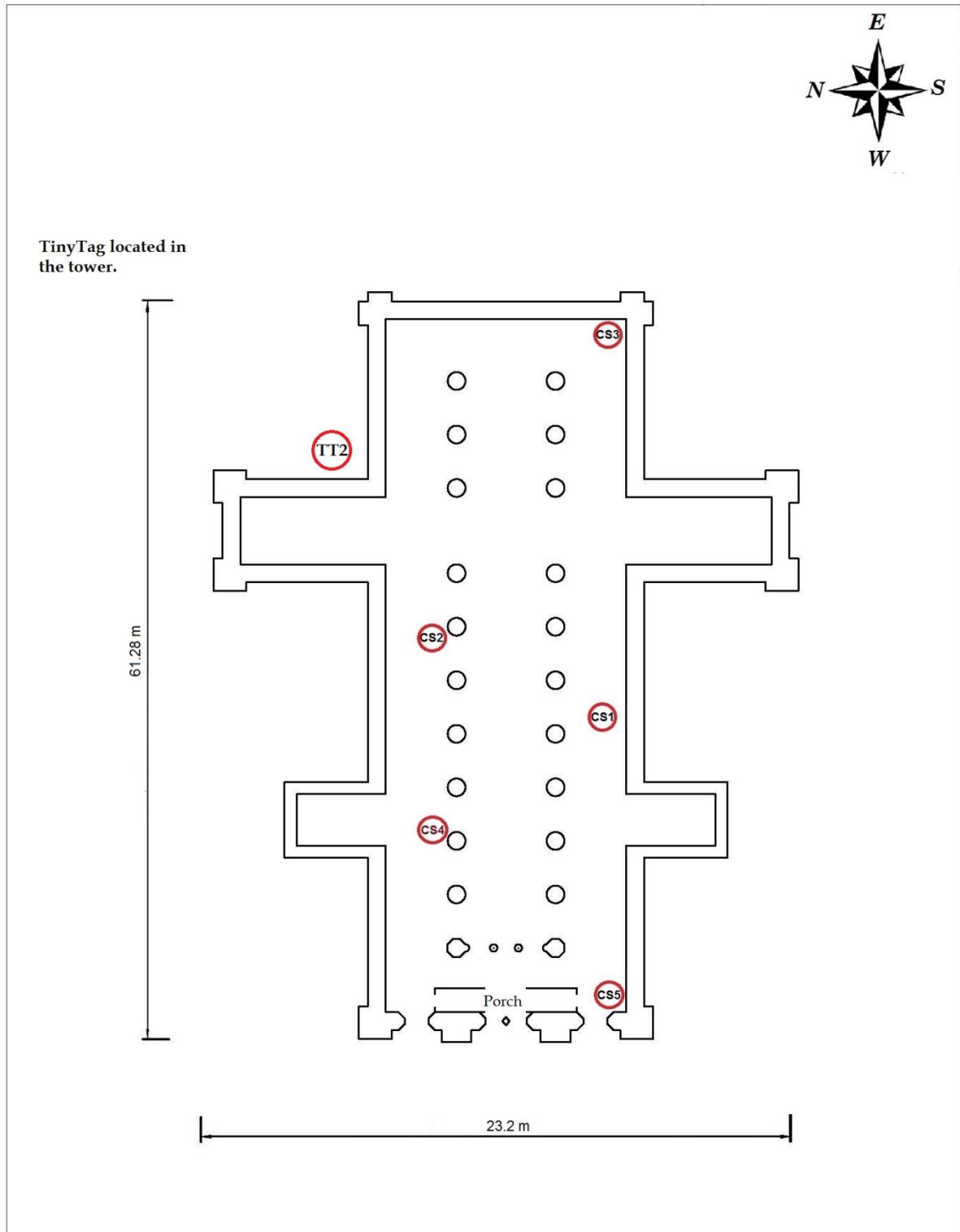

St. Mary's Cathedral	Size:	22,500 m ³
Killarney - Ireland	Location:	52° 3' 31" N / 9° 31' 3" W
Roman Catholic Church	Heating type:	Underfloor / LPHW

Appendix 8.2 – Loggers' graphs

Logger CS1 St. Mary's Killarney

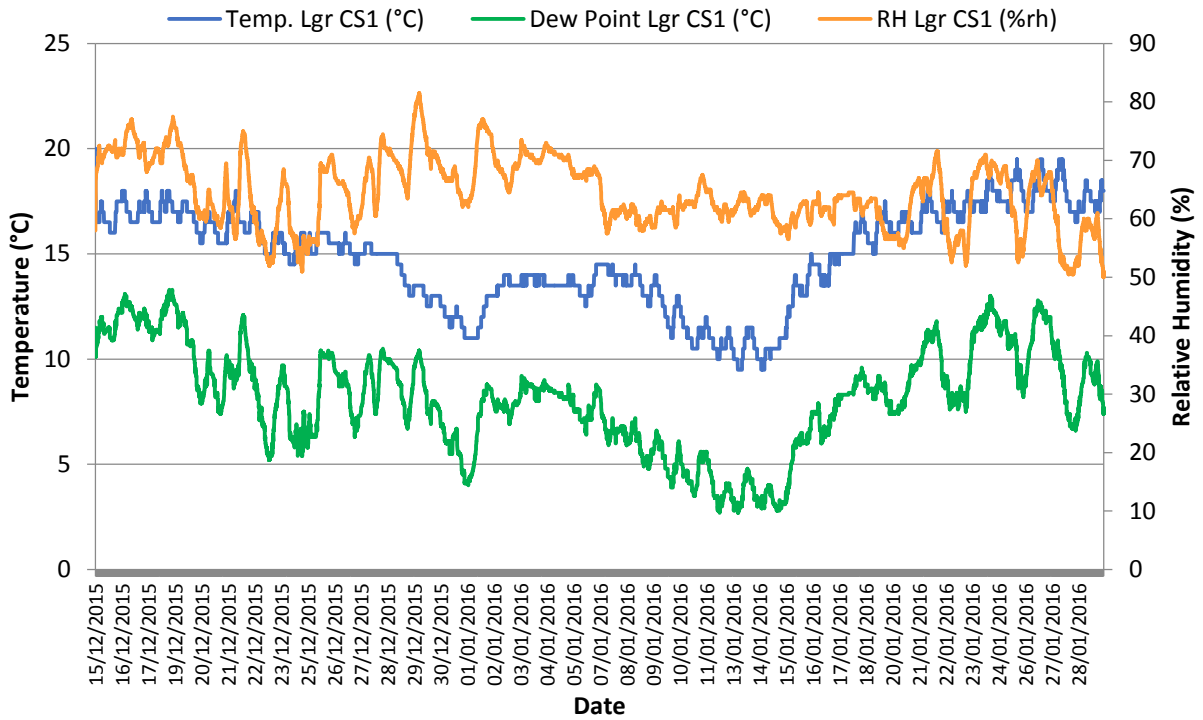

Logger CS2 St. Mary's Killarney

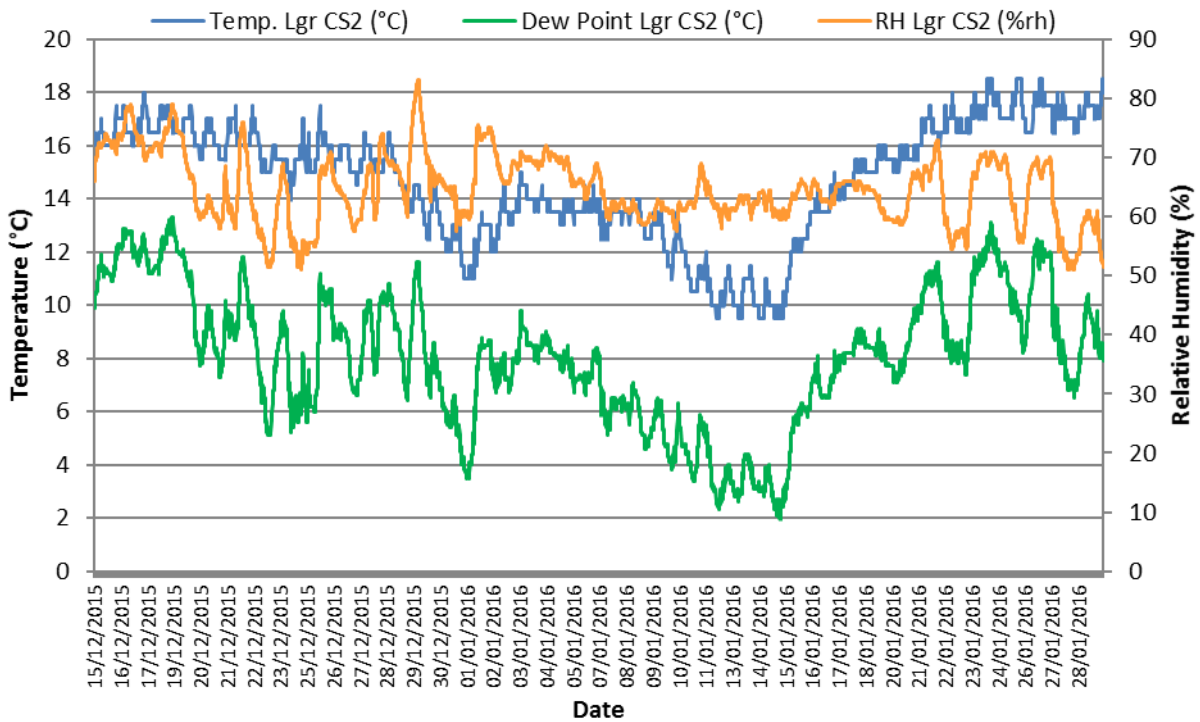

Logger CS3 St. Mary's Killarney

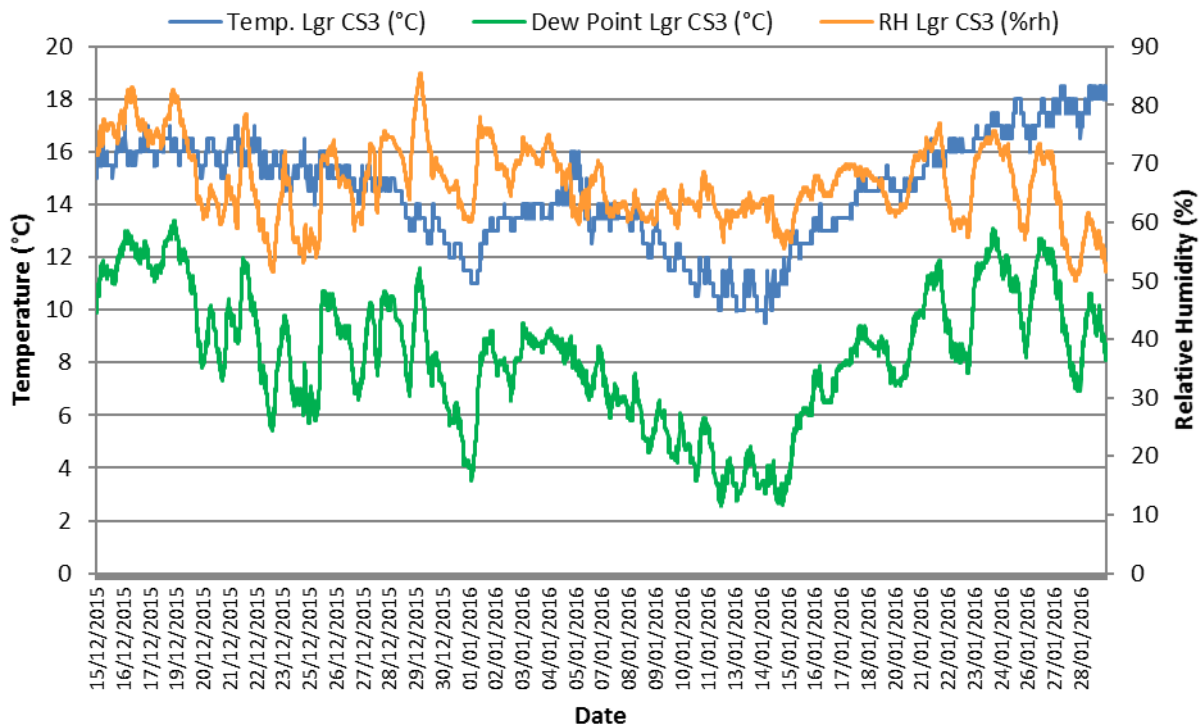

Logger CS4 St. Mary's Killarney

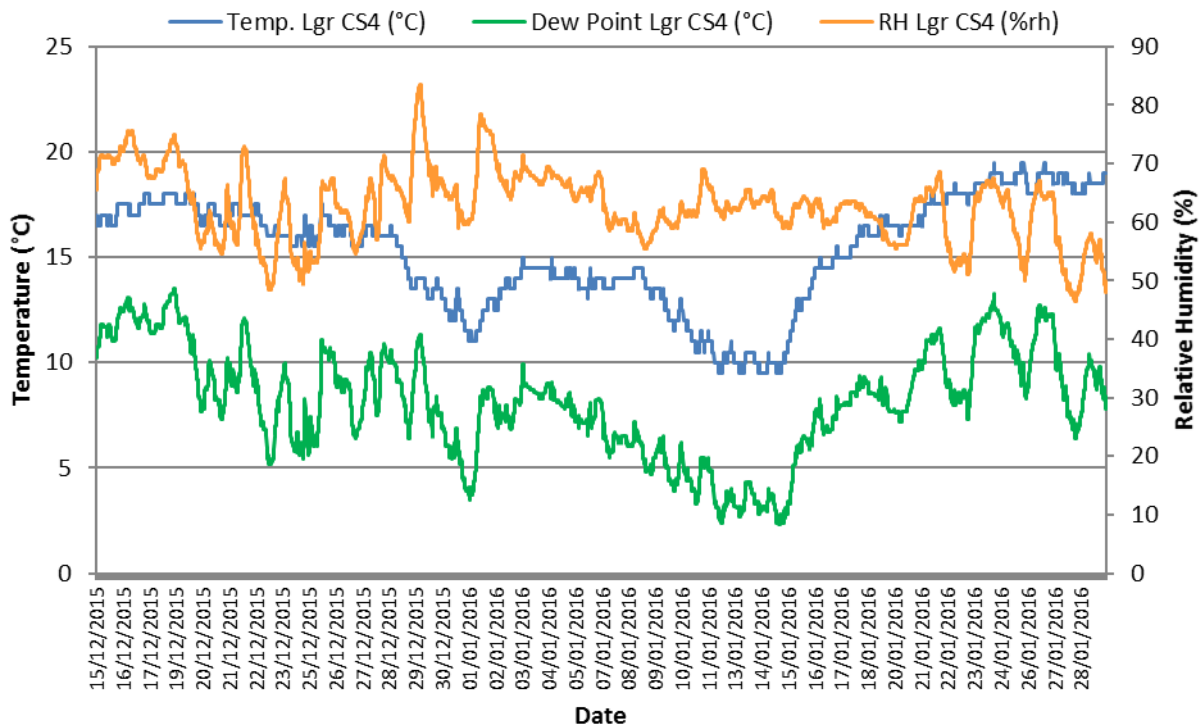

Logger CS5 St. Mary's Killarney

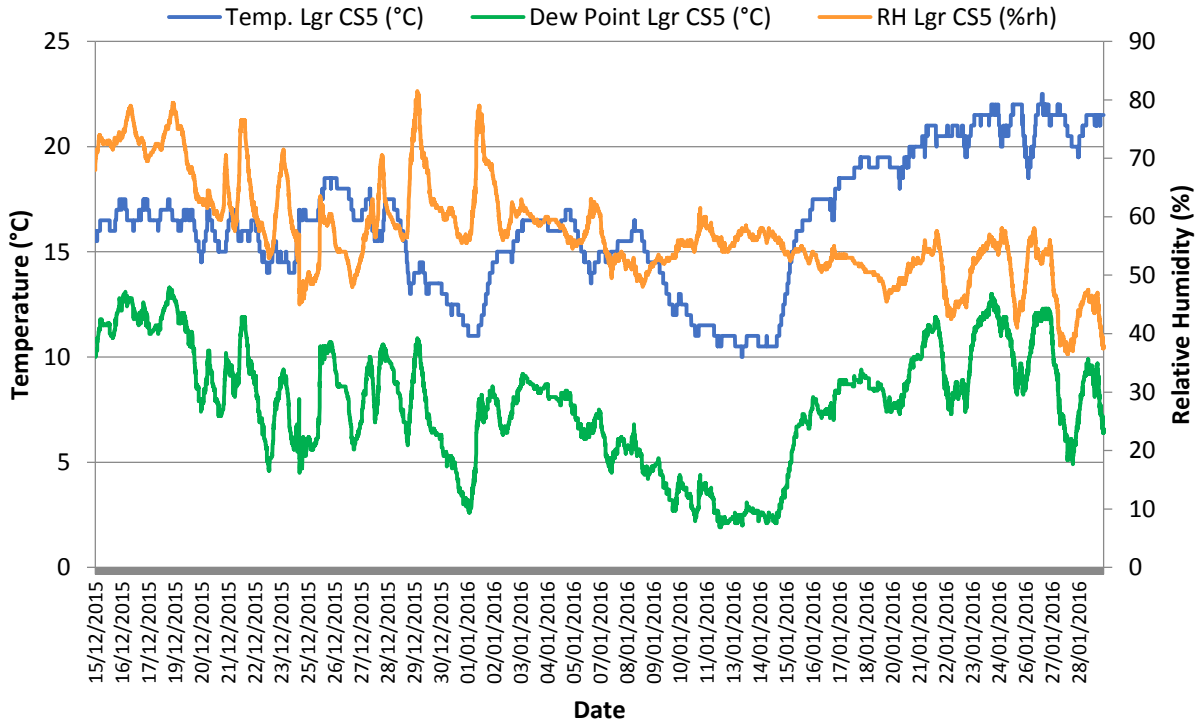

Appendix 8.3 – Tinytag graph (outside T and RH)

TT2 Killarney 12/15

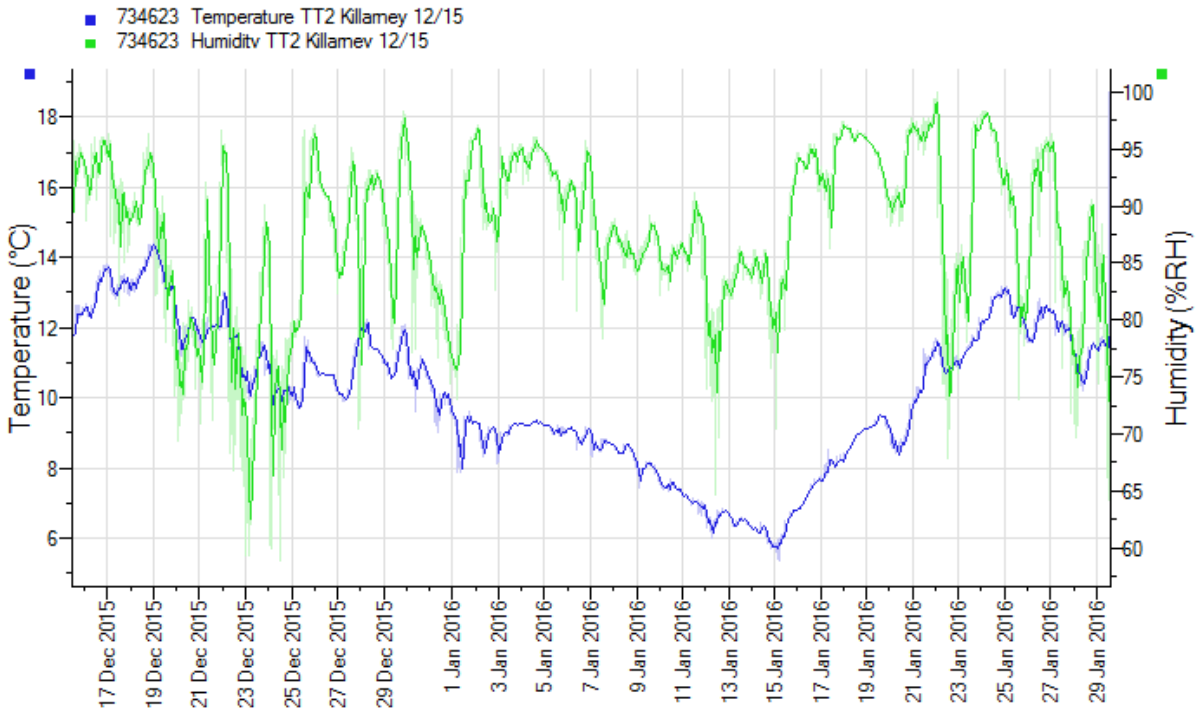

Appendix 9 – Saint Mel’s Roman Catholic Cathedral



Longford

Name: Cathedral Church of Saint Mel.

Location: Longford City, Republic of Ireland.

Tradition: Roman Catholic.

Outline history: St. Mel to whom Longford cathedral is dedicated is reputed to have been a contemporary of St. Patrick and the pair of them are supposed to have travelled from Britain to Ireland together. St. Mel died in circa 488. A Dominican Friary existed in Longford since the 1400s but the first stone of the cathedral was laid in 1840 but it was not consecrated until 1893, largely as a result of the famine in Ireland during which time the work on the cathedral stopped since the parish had other priorities at that time. The cathedral is cruciform in shape with six columns down each side of the nave, each column weighing 28 tons, and the cathedral is neoclassical in design. The sanctuary area was completely remodeled in 1975 as a result of the Second Vatican Council but this did not meet with universal approval amongst the parishioners. The biggest change in the history of the cathedral was caused in December 2009 when the building was completely destroyed by fire. It was rebuilt at a cost of €30m and reopened in December 2014. The rebuilt building is filled with the best of Irish art and craftsmanship although the new organ was made in Italy. The floors are tiles and are well insulated. The ceiling is wooden, plastered and painted and the void between the ceiling and the roof is also insulated. The walls are stone and are not insulated and are one of the few remaining structures which survived the fire. The pews and confessionals are made of wood and being new and hygroscopic will take some time to adjust to the internal environment within the building.

Appendix 9.1 – Floor plan with loggers and TinyTag location

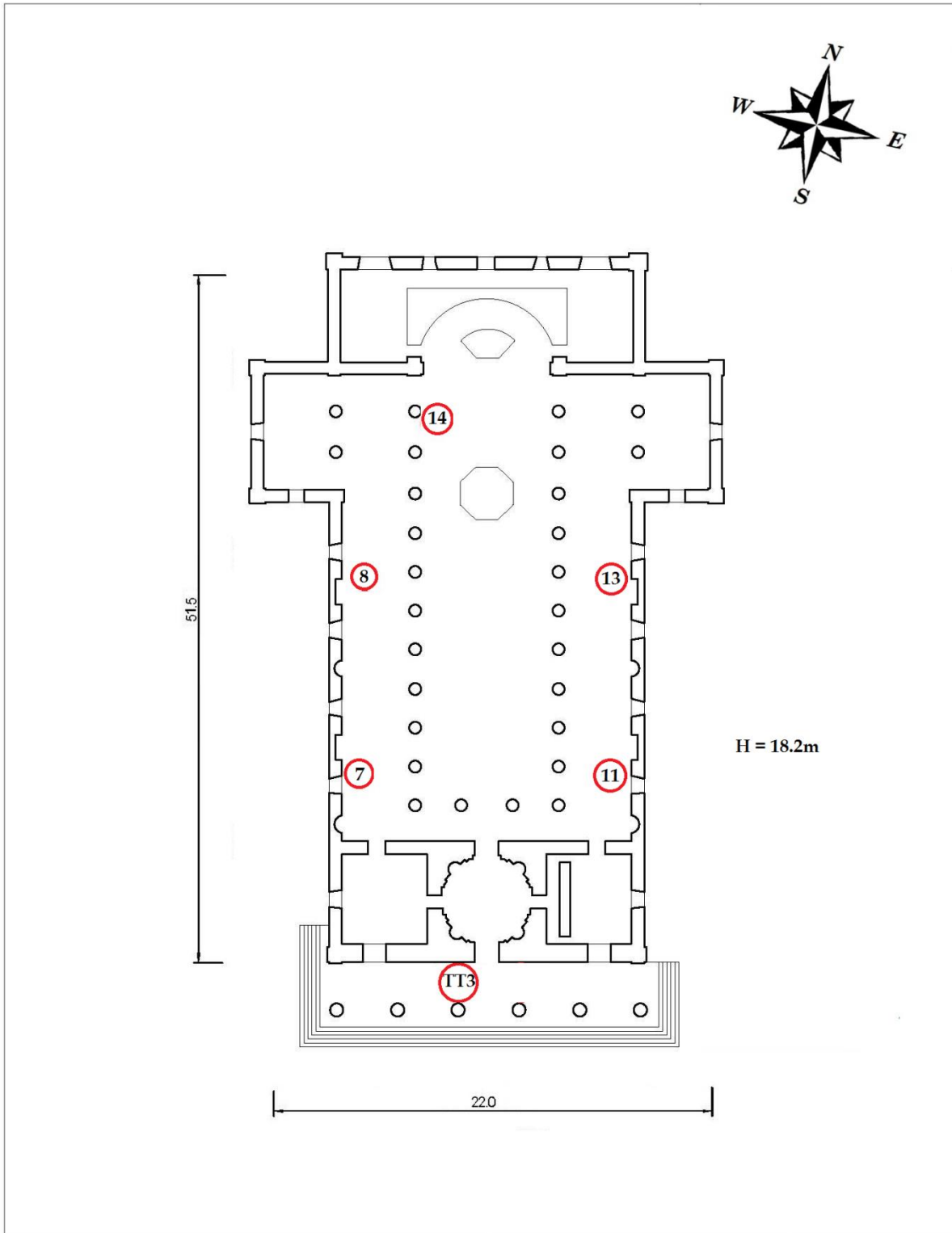

<p>St. Mel's Cathedral</p>	<p>Size: 22,500 m³</p>
<p>Longford - Ireland</p>	<p>Location: 53° 43' 38" N / 7° 47' 46" W</p>
<p>Roman Catholic Church</p>	<p>Heating type: Underfloor & LPHW</p>

Appendix 9.2 – Loggers' graphs

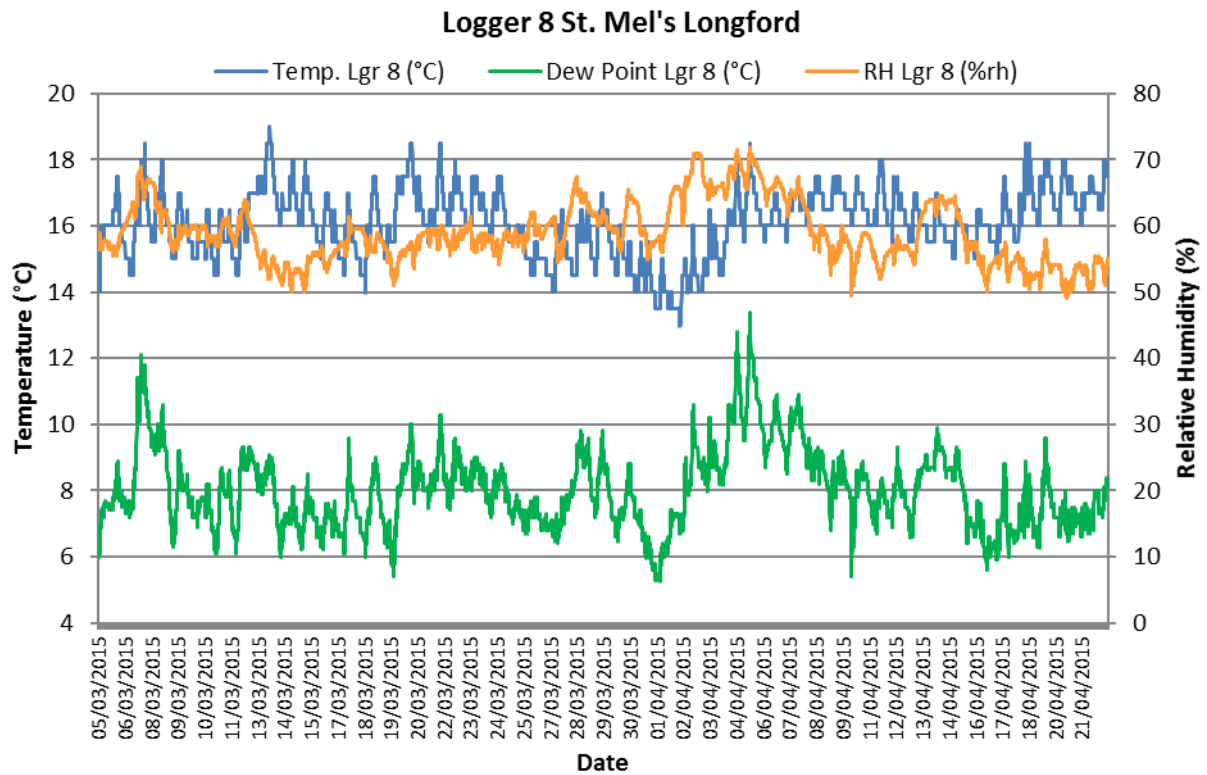
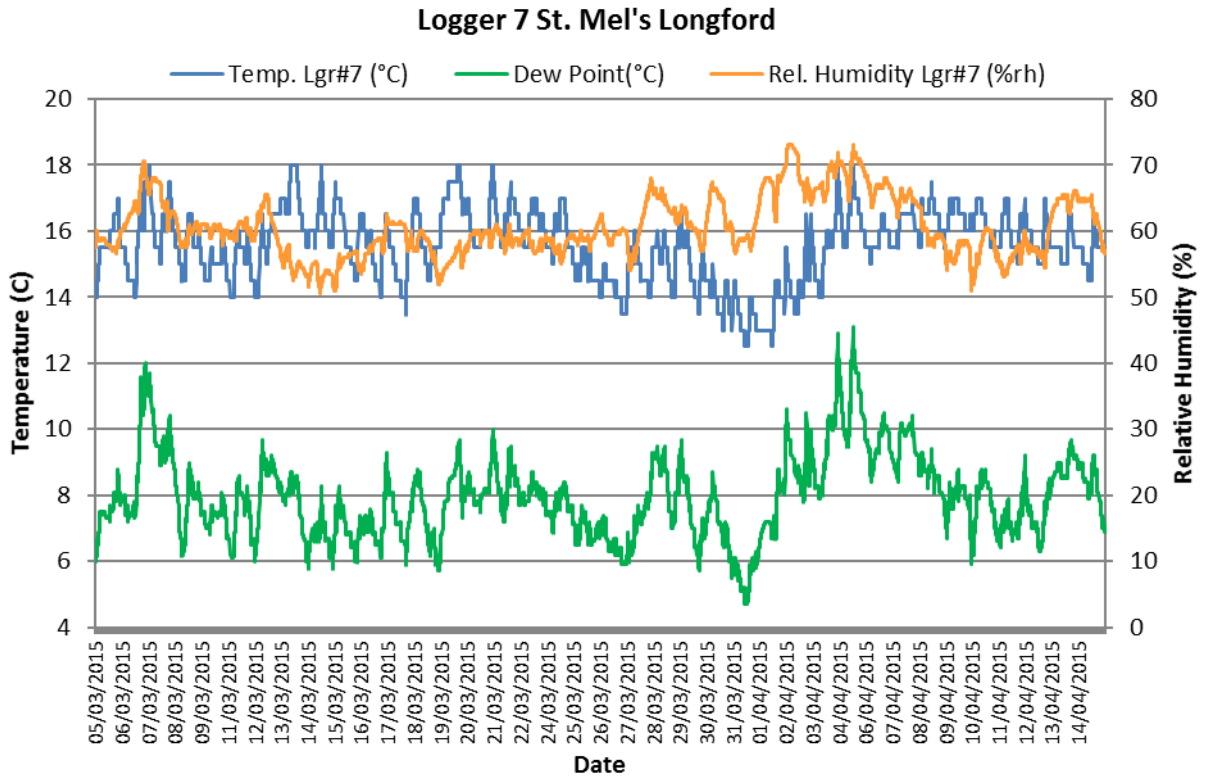

Logger 11 St. Mel's Longford

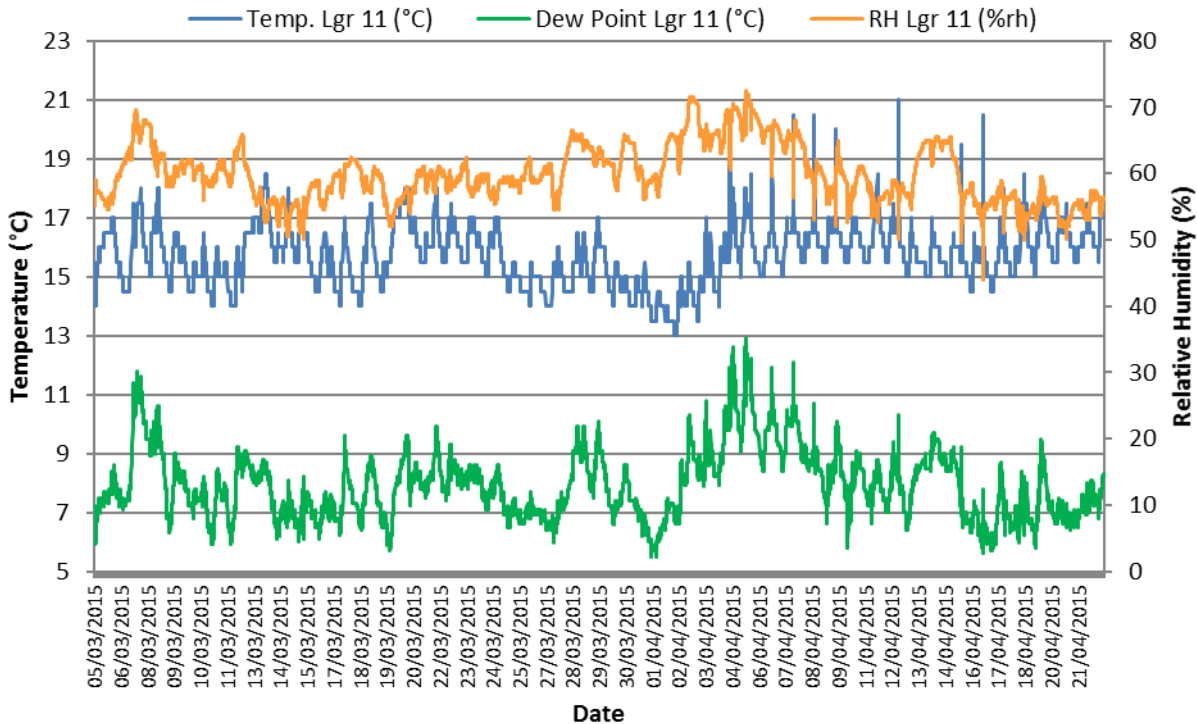

Logger 13 St. Mel's Longford

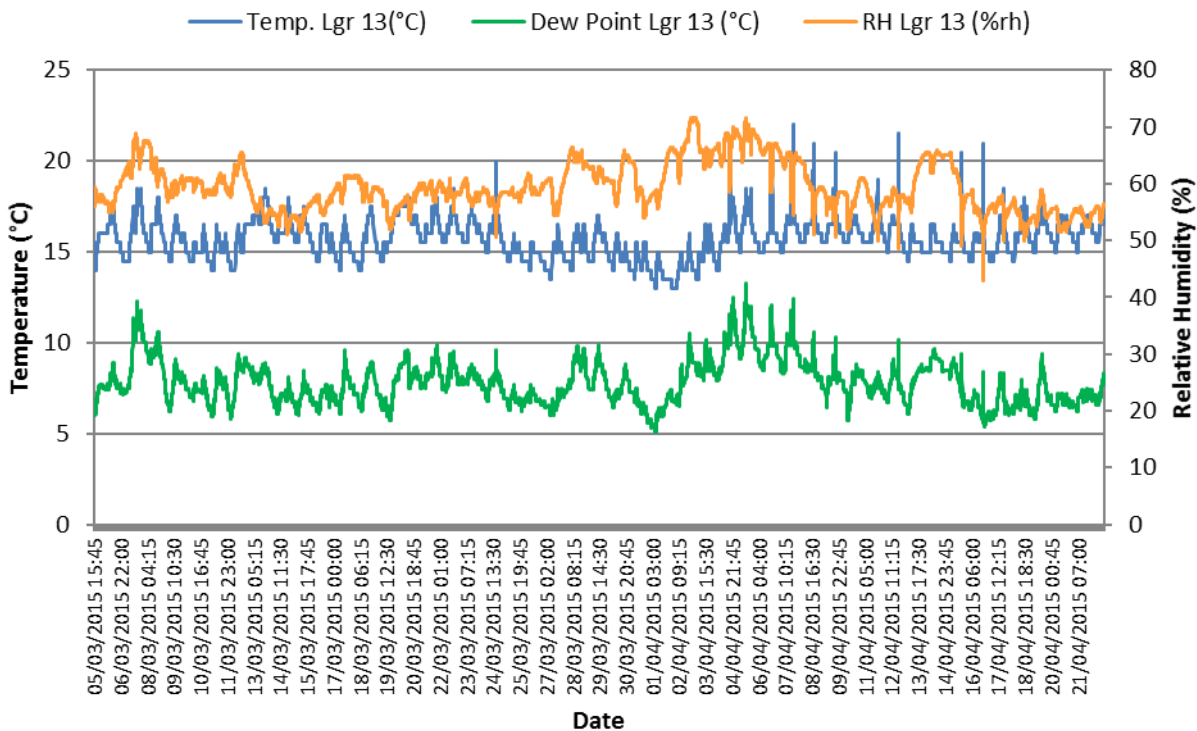

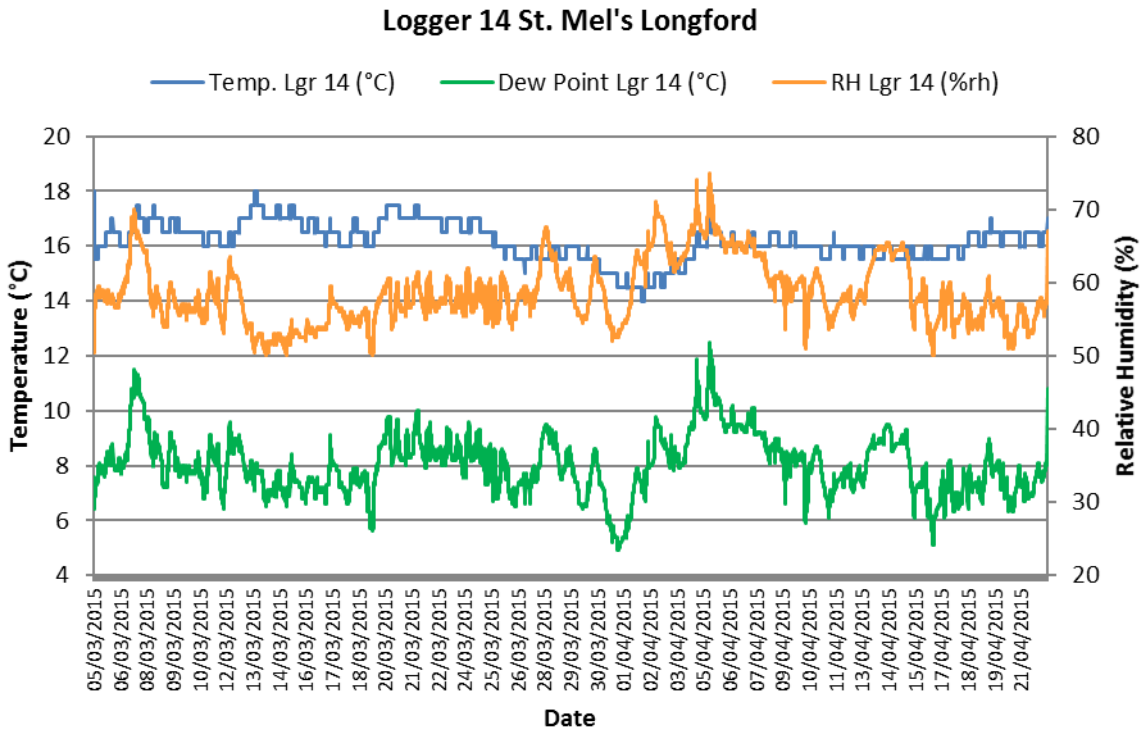

Appendix 9.3 – Tinytag graph (outside T and RH)

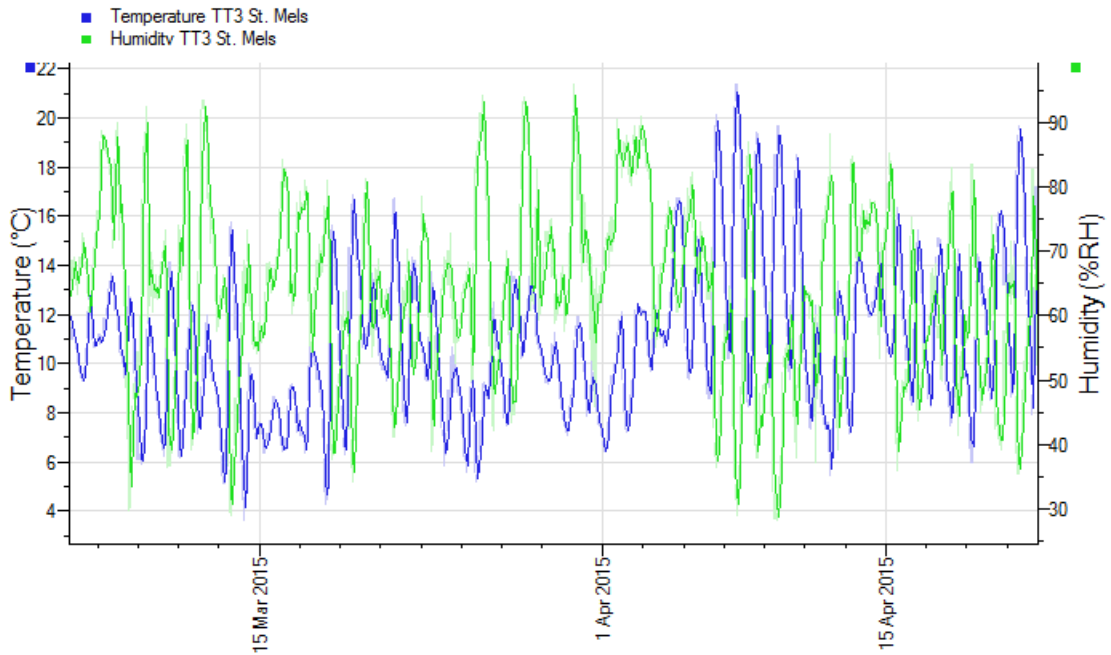

Appendix 10 – St. Mary’s Roman Catholic Cathedral

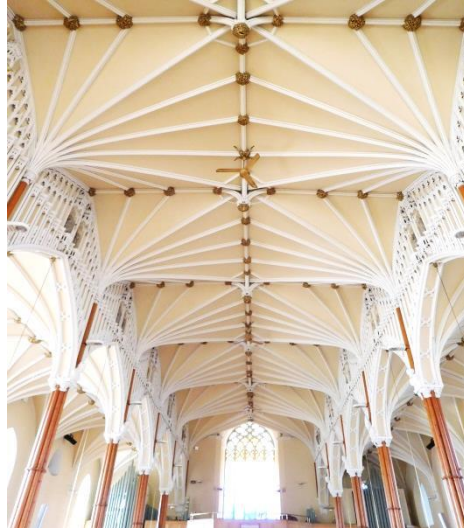

Cork

Name: Cathedral of St. Mary and St. Anne.

Location: Cork City, Republic of Ireland.

Tradition: Roman Catholic.

Outline history: This cathedral, which was dedicated in 1808 is situated in an historic part of the city of Cork near to one of the 13th Century city gates. In the 18 century this part of Cork was part of the worldwide trade in beef and particularly butter. The present cathedral is built on the site of an older church which was known locally as the North Church which explains why the present cathedral is often referred to as the North Cathedral. The cathedral is perhaps Gothic in design but has been much added to and altered over the years, which makes it difficult to ascribe a particular architectural style to the building. The cathedral was badly damaged by fire in 1820 as a result of sectarian unrest surrounding the issue of Catholic Emancipation. A tower was added in 1862-67 and major alterations carried out as a result of Vatican II (1962-65). The cathedral is the cathedral of the Roman Catholic Diocese of Cork and Ross. This is a cruciform church with a nave and side aisles. The floor is tiled and the ceiling is plaster and painted. It is not known if there is a void between the ceiling and roof or if this is insulated. The pews are made of wood and there is a pipe organ suited above the west end door. The walls are stone with plaster on the inside. The windows are single glazed with storm glazing on the outside.

Appendix 10.1 – Floor plan with loggers and TinyTag location

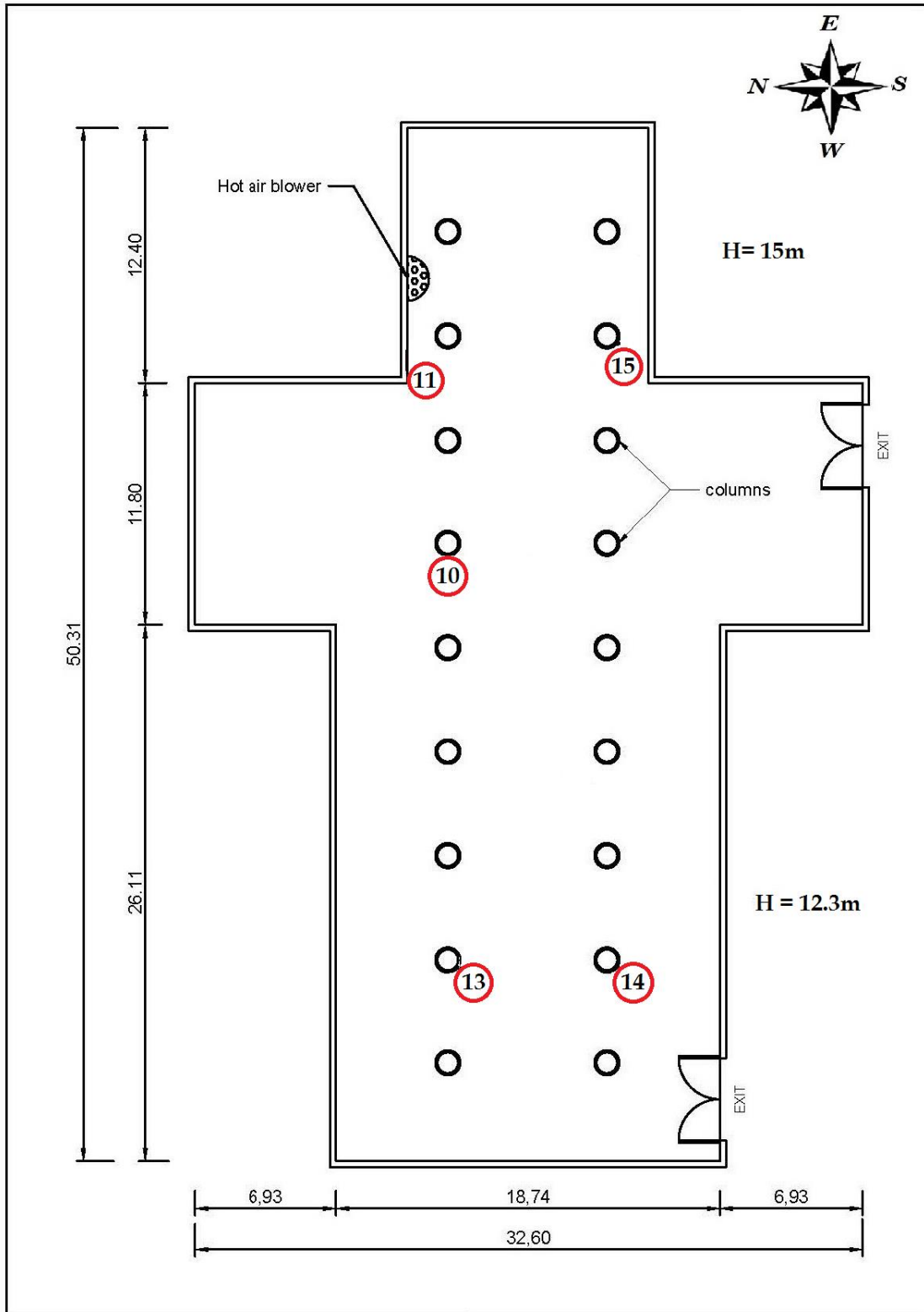

St. Mary's Cathedral Cork - Ireland Roman Catholic Church	Size:	13,000 m ³
	Location:	51° 54' 17" N / 8° 28' 34" W
	Heating type:	Hot air / LPHW

Appendix 10.3 – Loggers' graphs

Logger 10 St. Mary's Cork

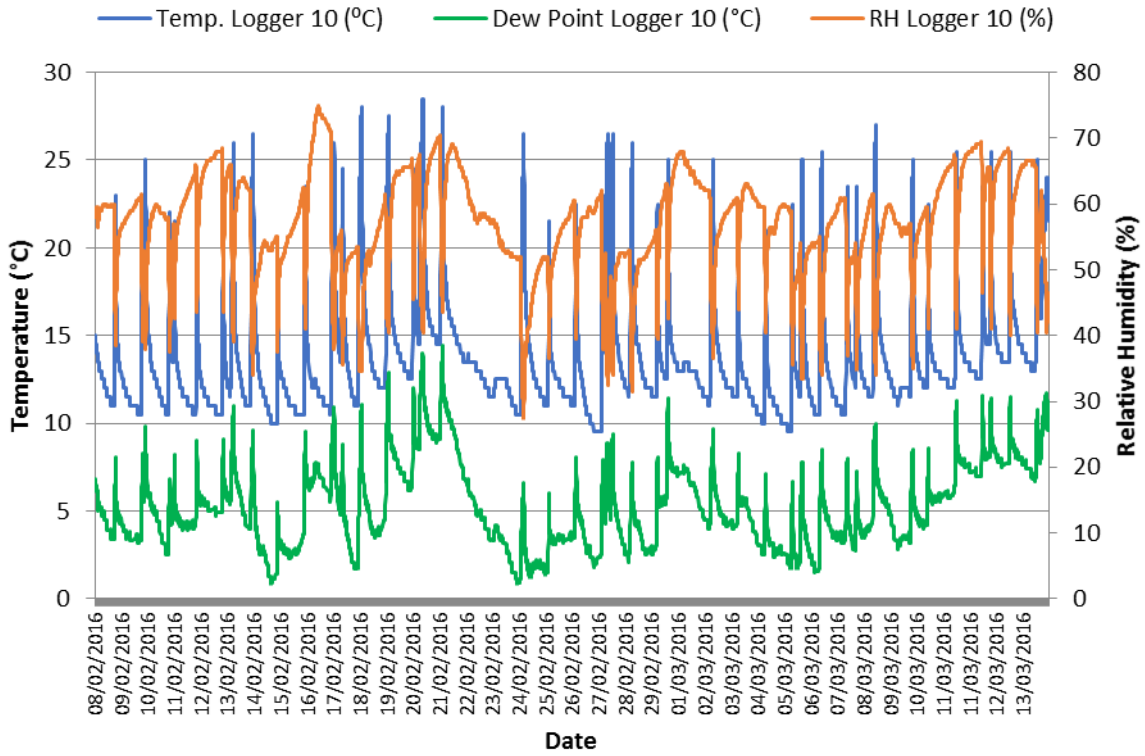

Logger 11 St. Mary's Cork

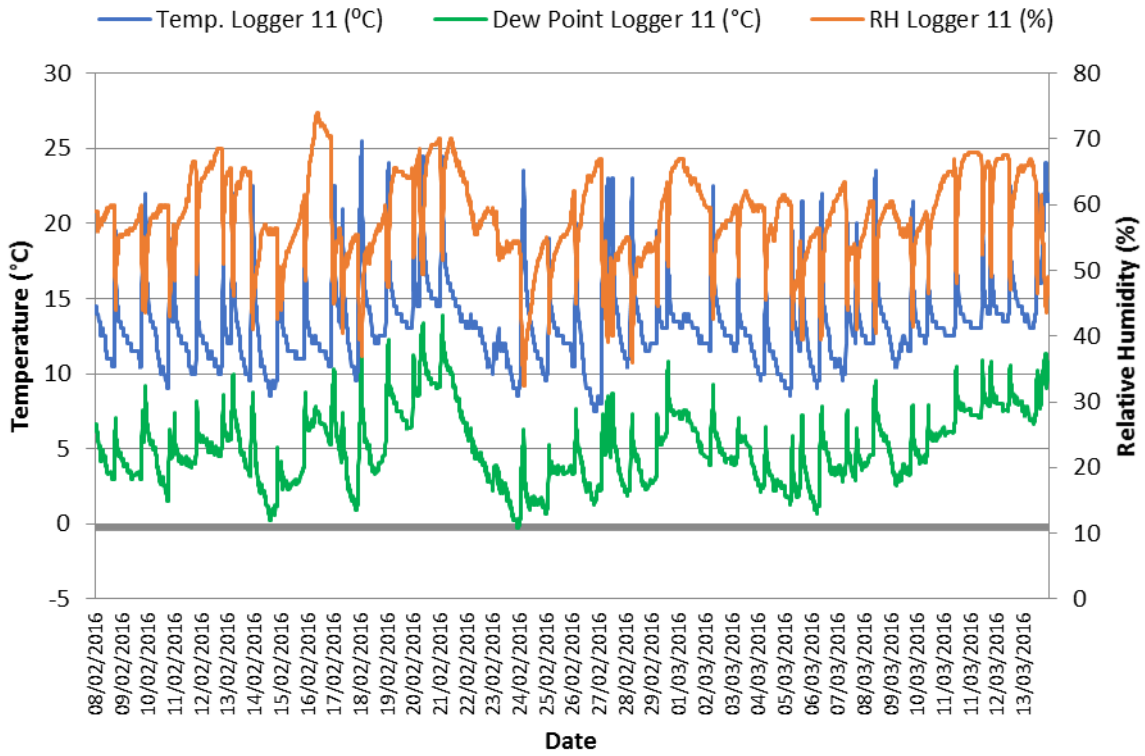

Logger 13 St. Mary's Cork

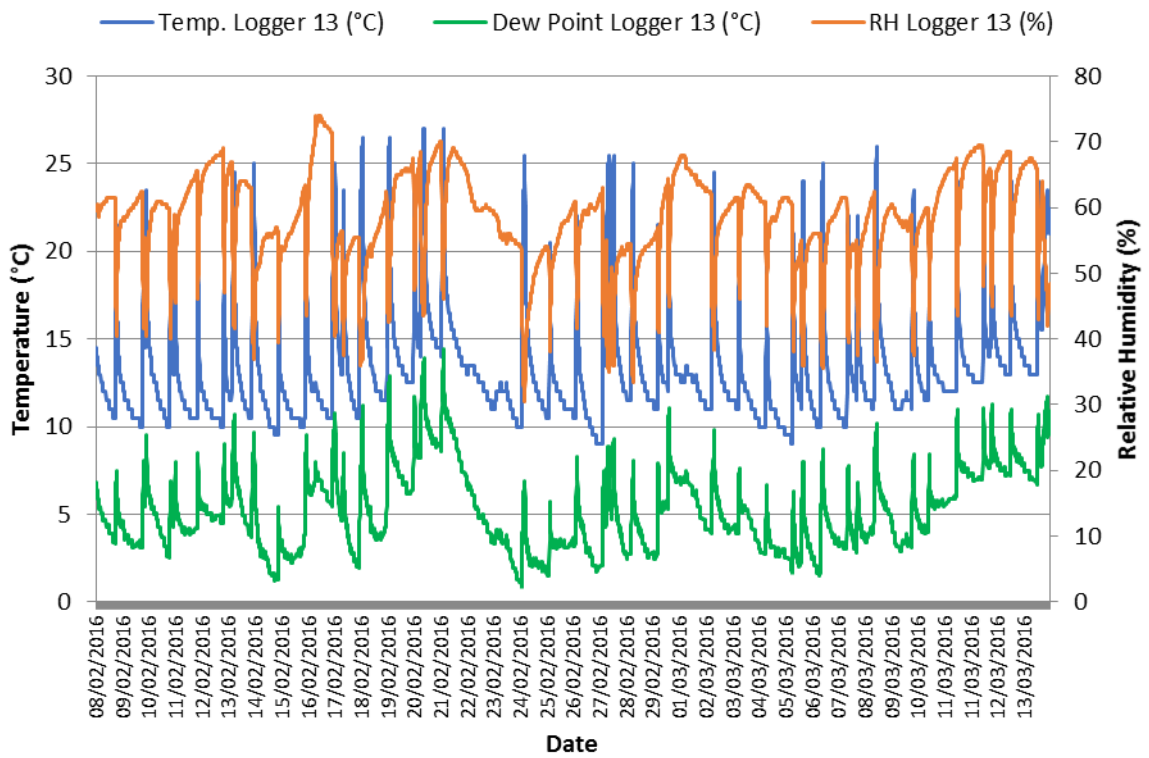

Logger 14 St. Mary's Cork

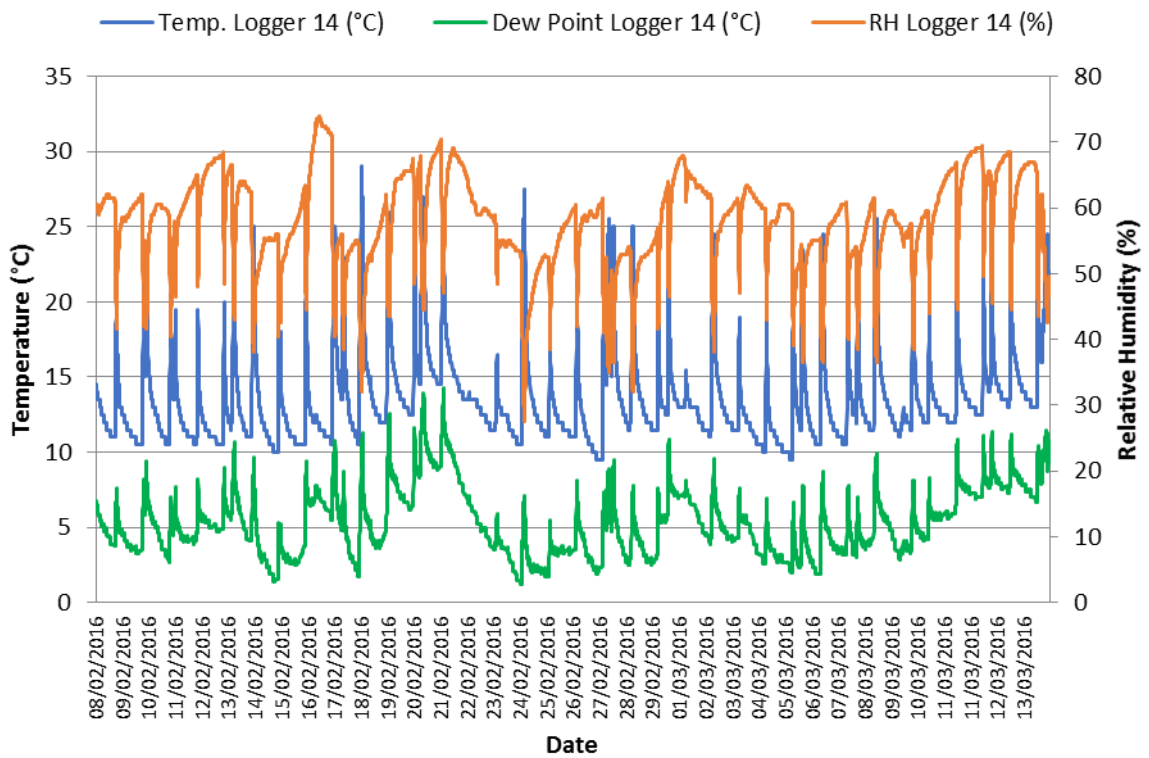

Logger 15 St. Mary's Cork

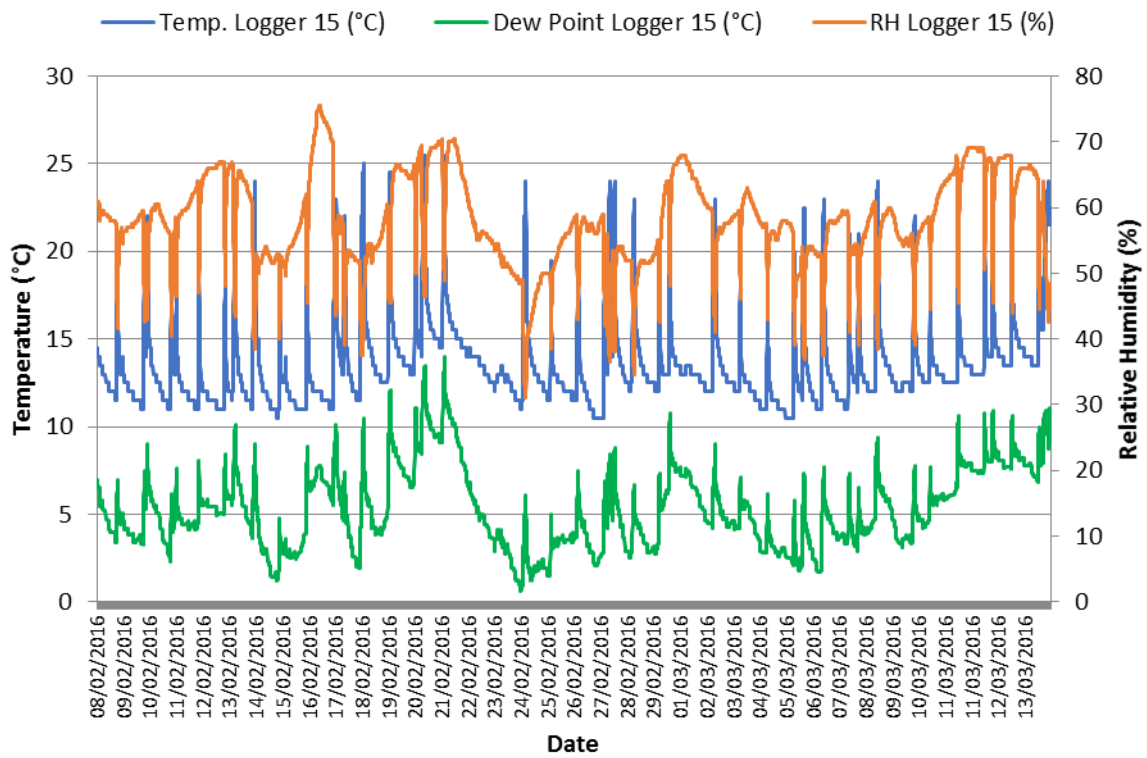

Appendix 10.4 – Tinytag graph (outside T and RH)

TT3 St. Mary Cork

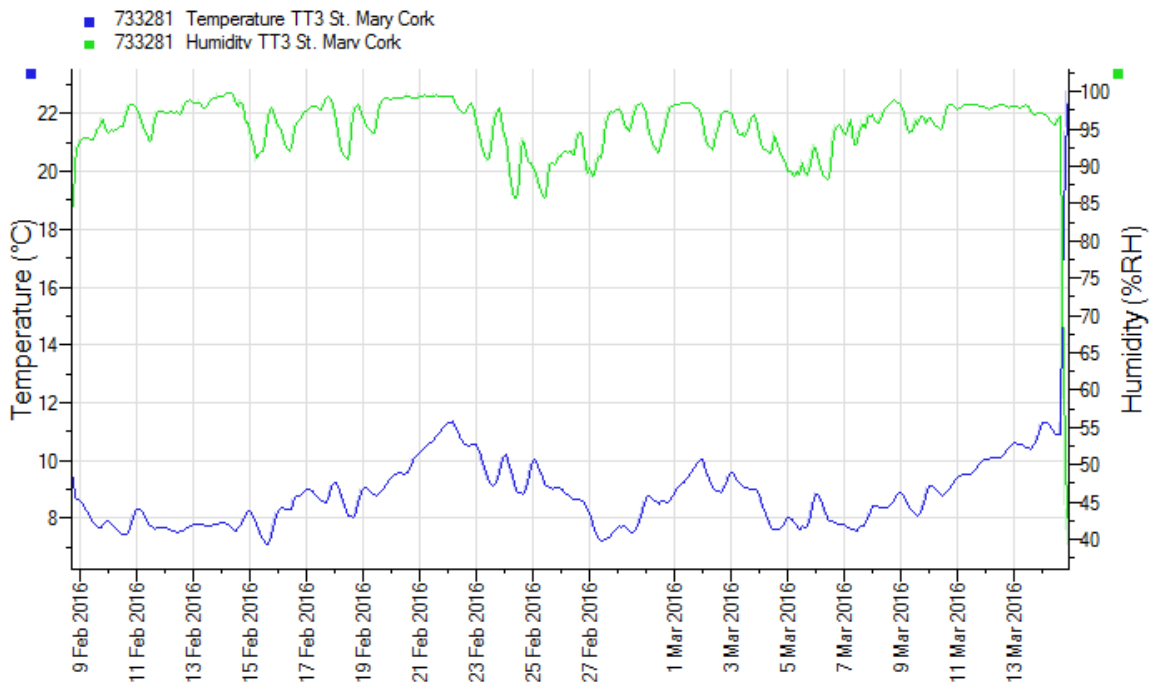

Appendix 11 – St Columb's Church of Ireland Cathedral



Nave, looking East. (By Andreas F. Borchert. License: CC BY-SA 3.0 de)

Derry

Name: The Cathedral church of St. Columb.

Location: Derry/Londonderry City, Northern Ireland.

Tradition: Church of Ireland.

Outline history: St. Columb founded a monastery on or near to the site of the current cathedral in the year circa 546. The present cathedral was completed in 1633 after James 1 of England asked the City of London to rebuild the city in 1608. Part of the conditions for rebuilding the city was that a cathedral would be built and that the name of the city would be changed to Londonderry. This was done and the new cathedral was built on a hill just inside the city walls. The cathedral suffered substantial damage during the famous siege of 1689 when the tower was used as an artillery platform. The tower was destroyed but rebuilt in 1776. Many improvements to the inside and outside of the building were made over the decades but the cathedral again suffered badly during the 'troubles' in Northern Ireland and all of the stained glass in the North aisle was lost in a bomb explosion in 1989. Fortunately it had been well photographed and was able to be replaced. The architectural style of the current building is known as Ulster Gothic or Planters Gothic or Gothic Survival which was a continuation of Gothic architecture into the 16th and 17th centuries. The two cathedrals in Derry namely St. Columb's and the Roman catholic cathedral of St. Eugene can clearly be seen from each other. This building is straight without transepts. The walls are stone and the internal plaster was removed some years ago. There are side aisles which are separated from the nave by pillars. The ceiling is wooden but it is not known if the void between the ceiling and the roof is insulated.

Appendix 11.1 – Floor plan with loggers and TinyTag location

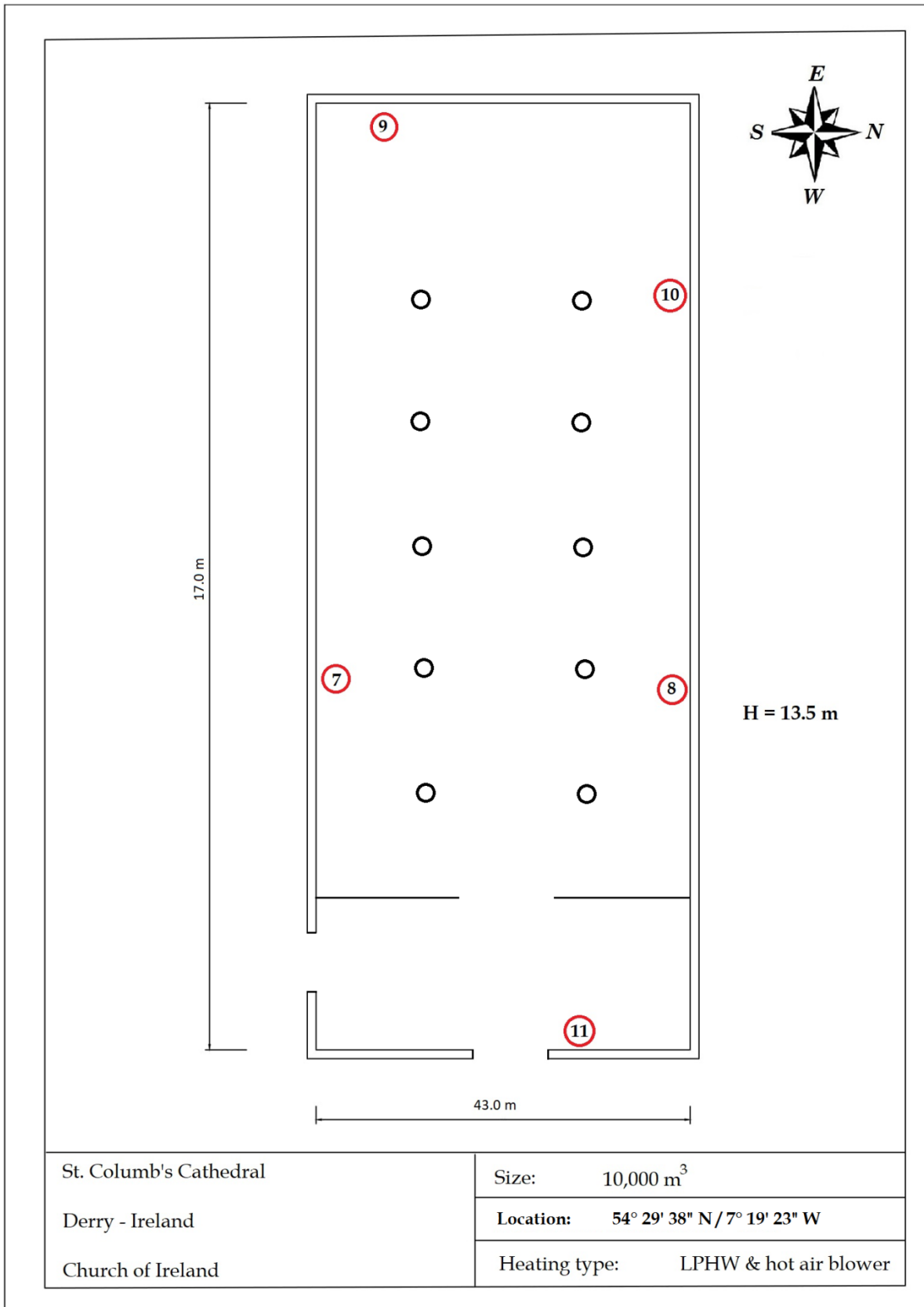

Appendix 11.2 – Loggers' graphs

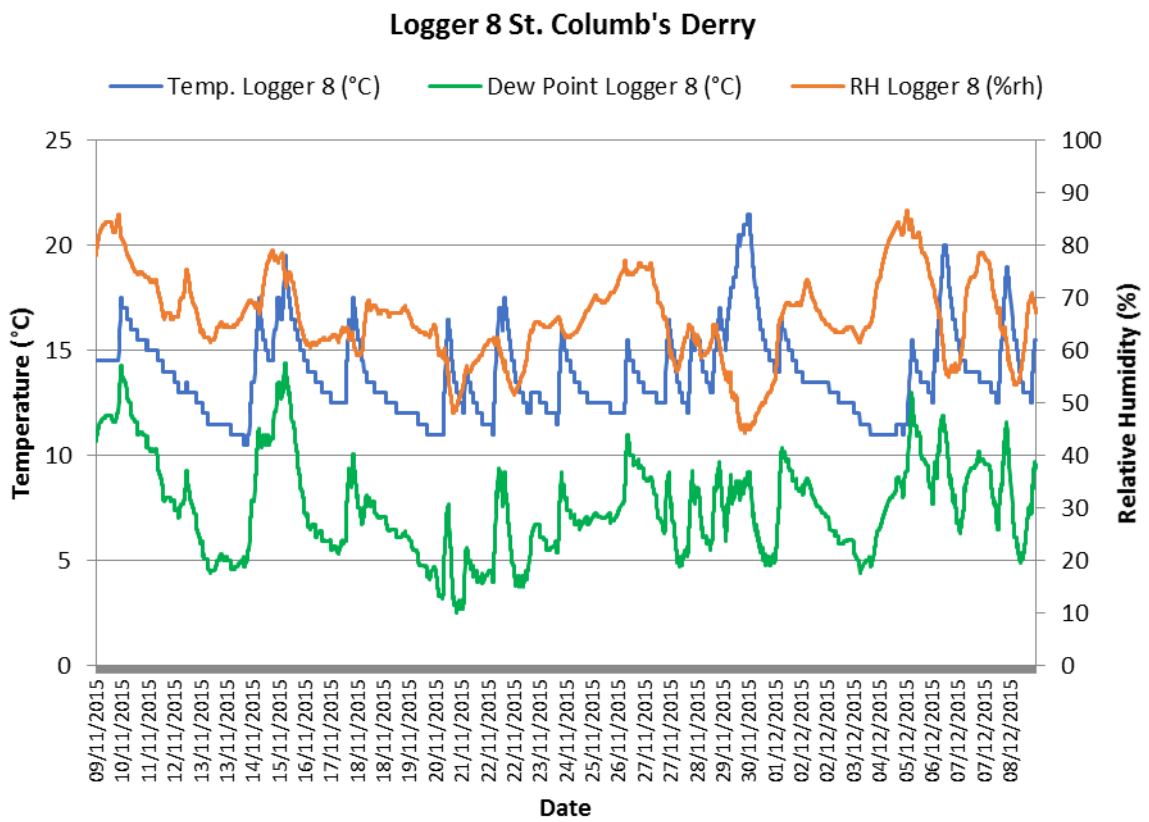
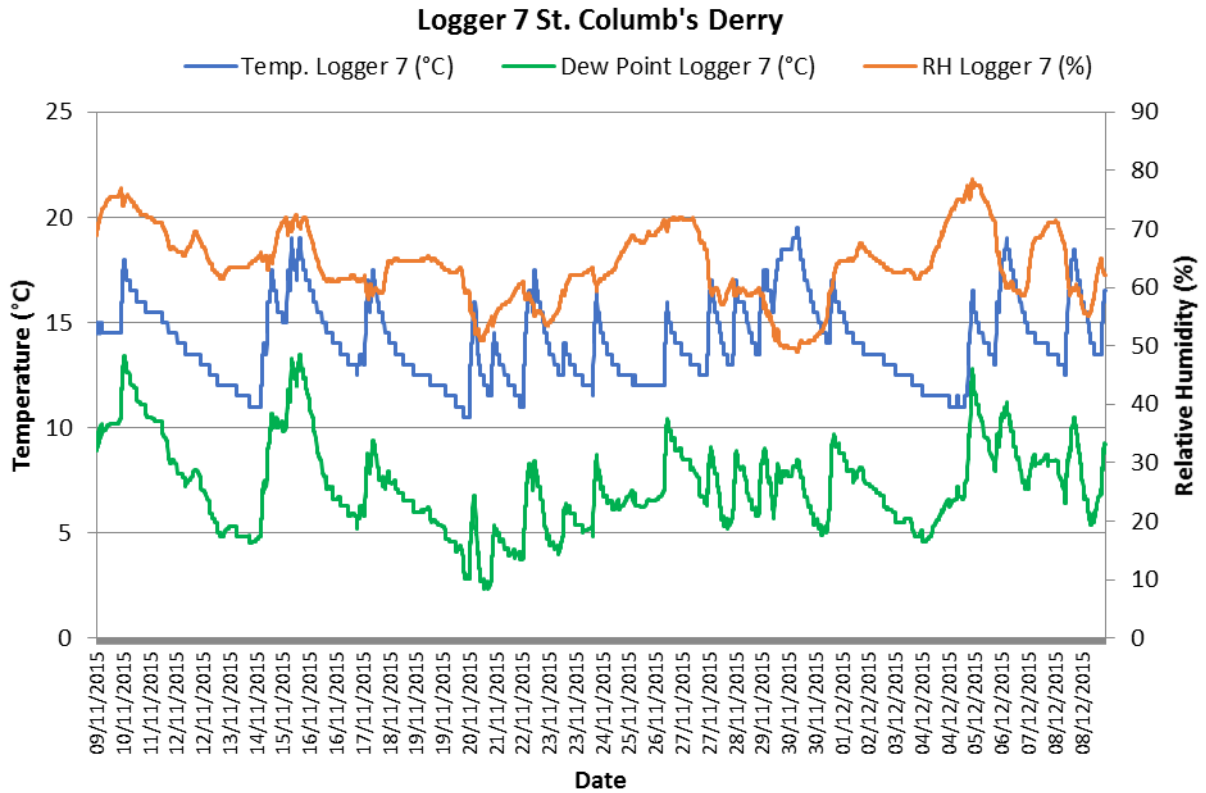

Logger 9 St. Columb's Derry

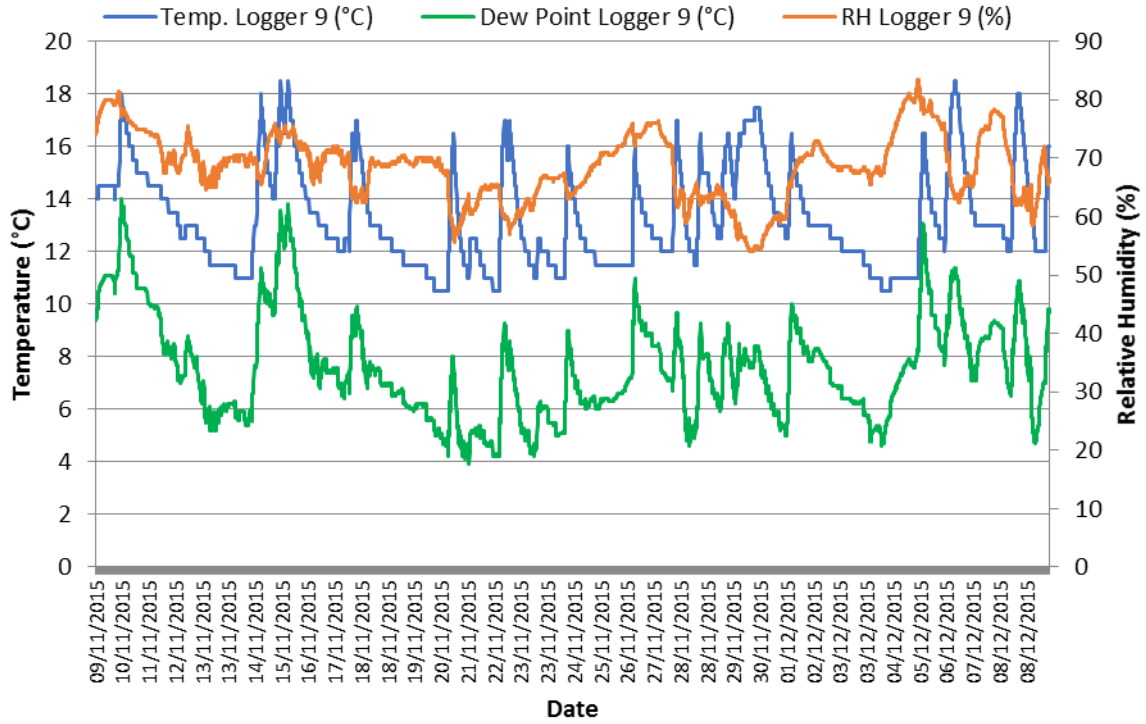

Logger 10 St. Columb's Derry

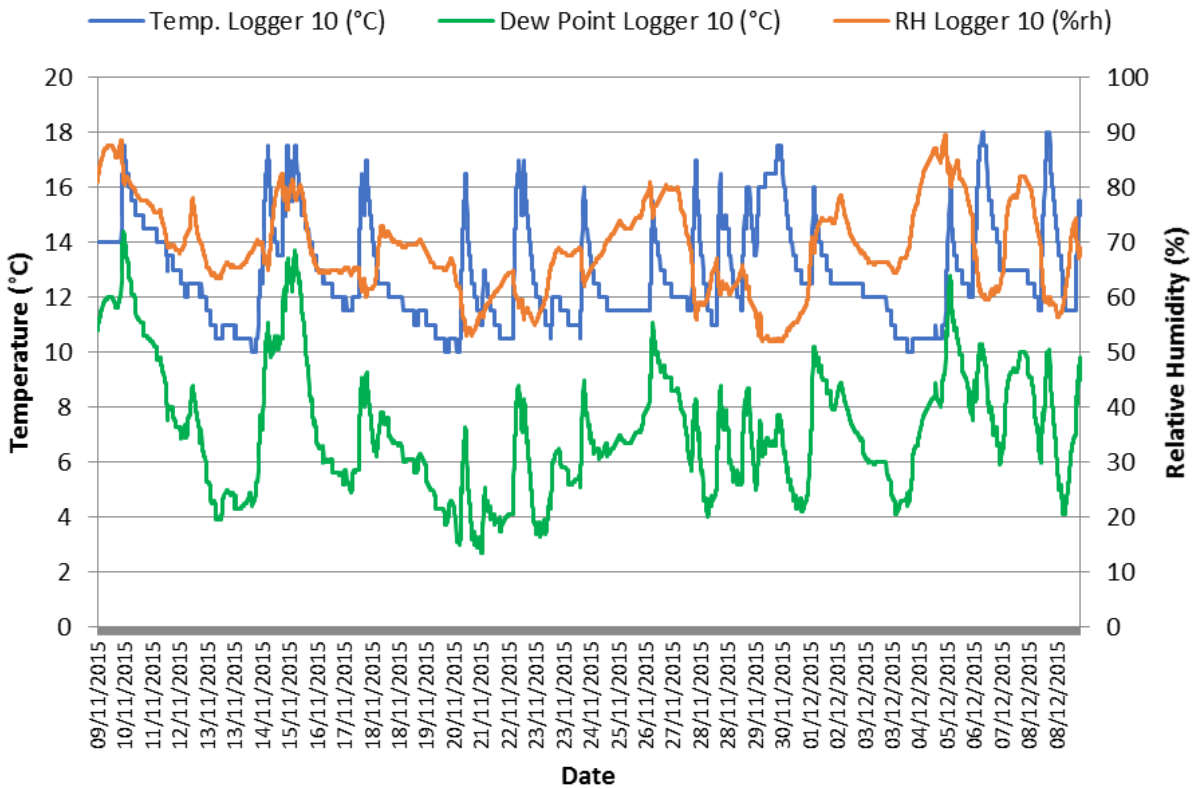

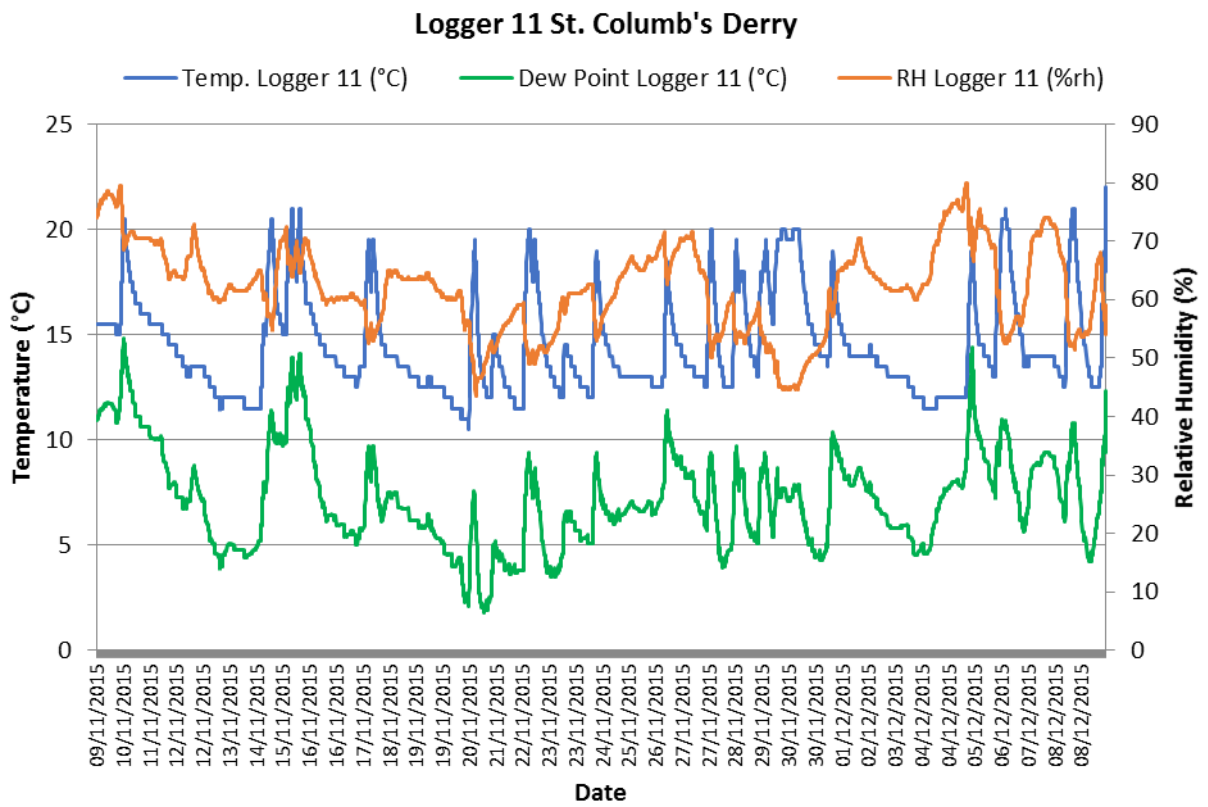

Appendix 11.3 – Tinytag graph (outside T and RH)

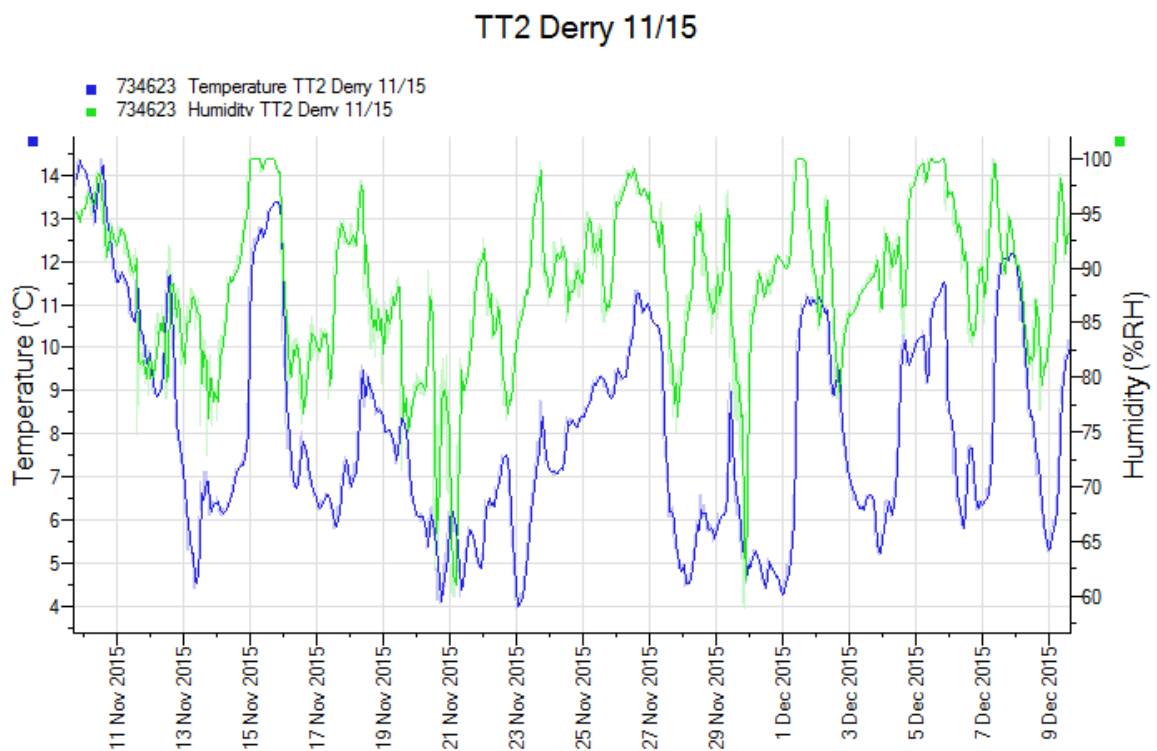

Appendix 12 – St. Patrick’s Church of Ireland Cathedral



Armagh

Name: The Cathedral Church of St. Patrick.

Location: Armagh City, Northern Ireland.

Tradition: Church of Ireland.

Outline history There has been a church on this site in Armagh since circa 444 and

Armagh has been the ecclesiastical capital of Ireland since that time. St. Patrick, the Patron Saint of Ireland, formed a monastery there and he said that the church in Armagh should take precedence over all other churches in Ireland. It still does today, although there are now two cathedrals in Armagh. Each cathedral is the pre-eminent cathedral for each tradition and the home of the senior archbishop of each tradition.

The Church of Ireland cathedral in Armagh is built on top of a hill from which the city derives its name, namely Ard Macha or Macha's height. It is recorded that the churches and cathedrals which were built on the site of today's cathedral, were destroyed by burning and sacking no less than 26 times between 670 and 1642. These burnings and sackings being the result of raids by Vikings and, local Irishmen. The cathedral has been renovated many times over the centuries and by 1834 was reported to be in a state of almost complete abandonment. A major refurbishment was carried out between 1834 and 1837 which demolished most of the original cathedral leaving the 13th century crypt which is under the east end of the cathedral, one of the few remains of the earlier cathedral. This is a cruciform cathedral with nave and side aisles as well as a number of side chapels. The floor is tiled and stone and the walls are stone with painted plaster internally. The windows are single glazed with storm glazing externally. The ceiling is painted and wooden but details of the void between the ceiling and roof are unknown. There is a crypt under the east end of the nave which is used as a visitor centre.

Appendix 12.1 – Floor plan with loggers and TinyTag location

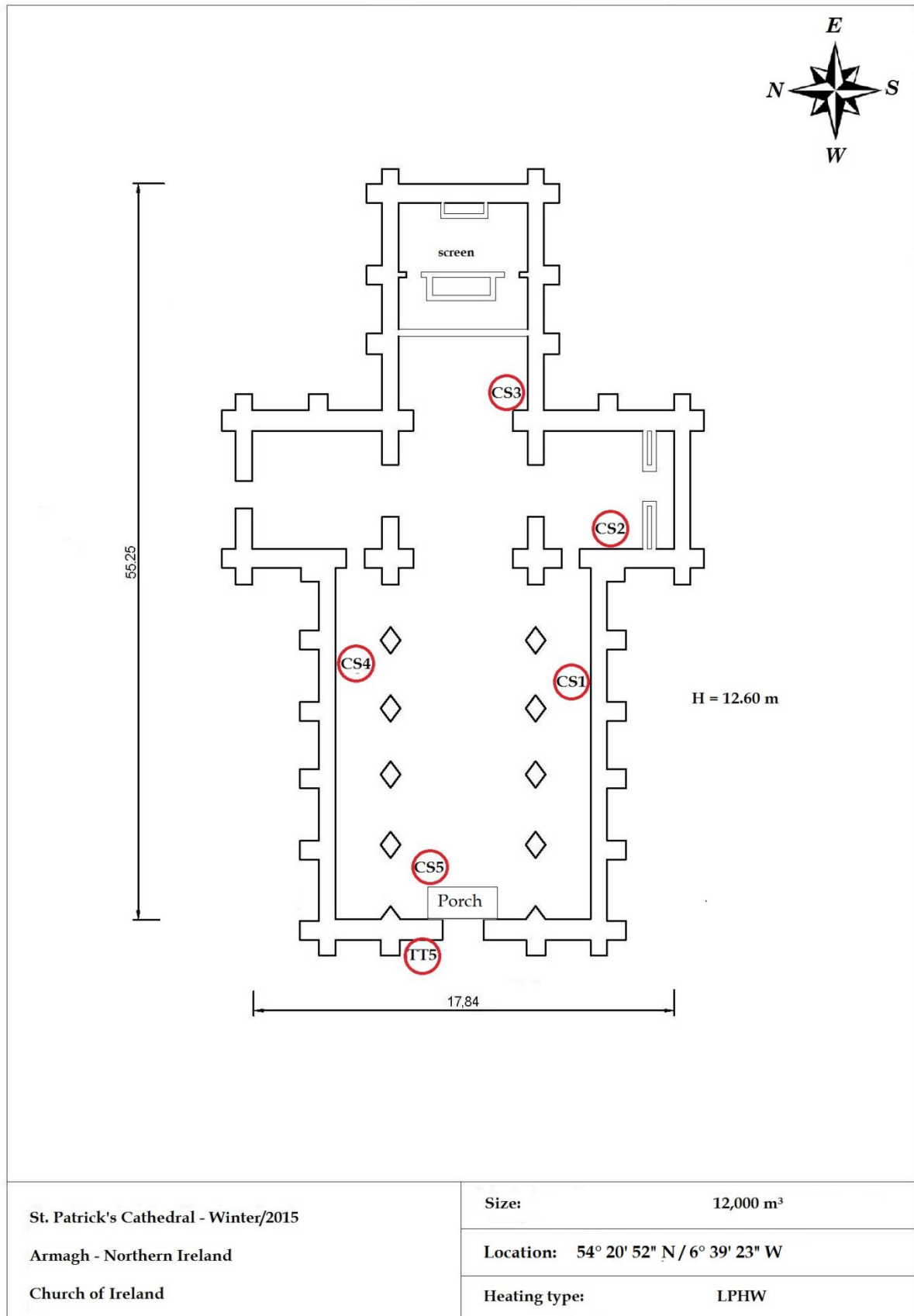

Appendix 12.2 – Loggers' graphs

Logger CS1 St. Patrick's Armagh CI

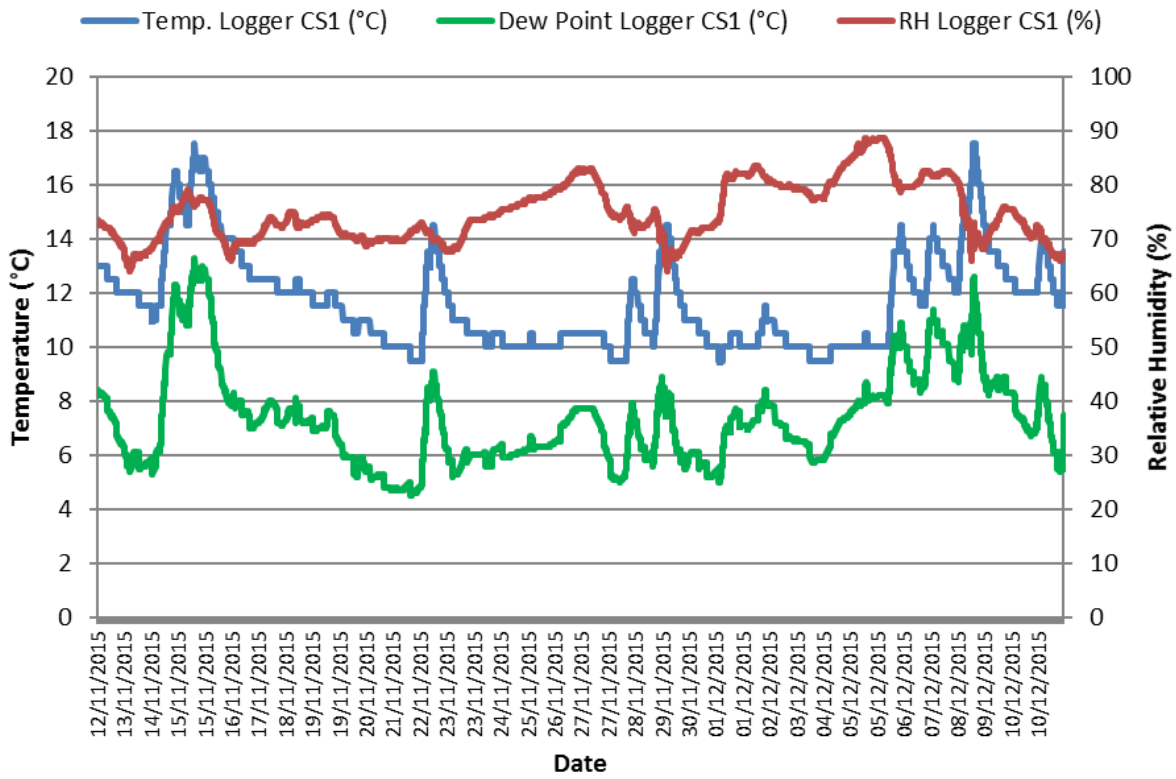

Logger CS2 St. Patrick's Armagh CI

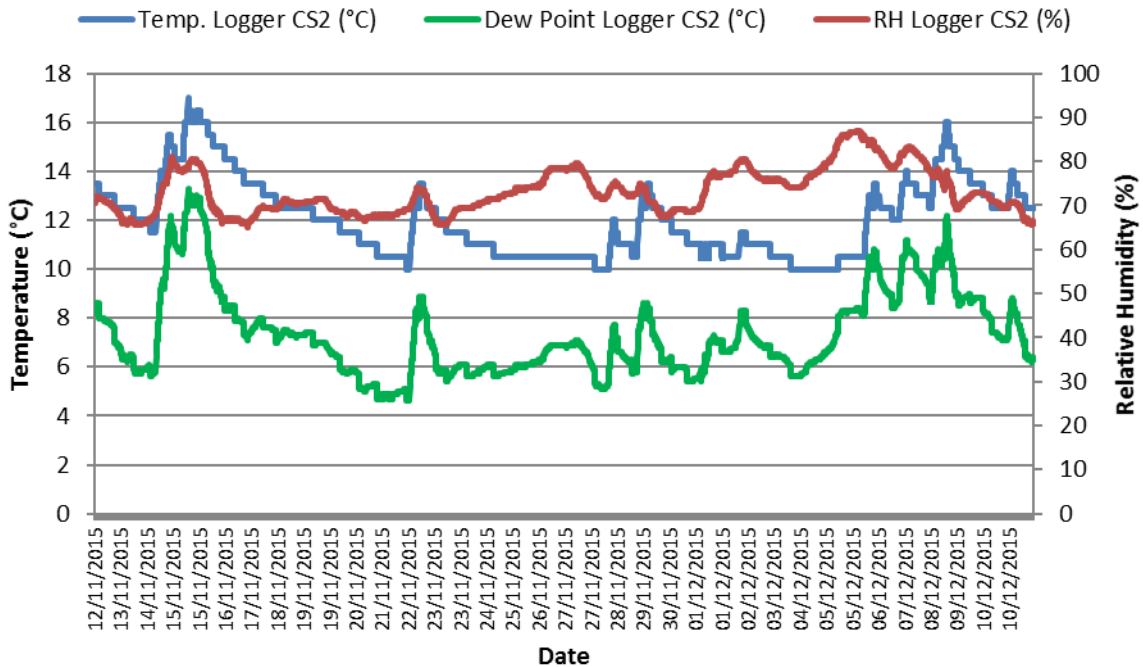

Logger CS3 St. Patrick's Armagh CI

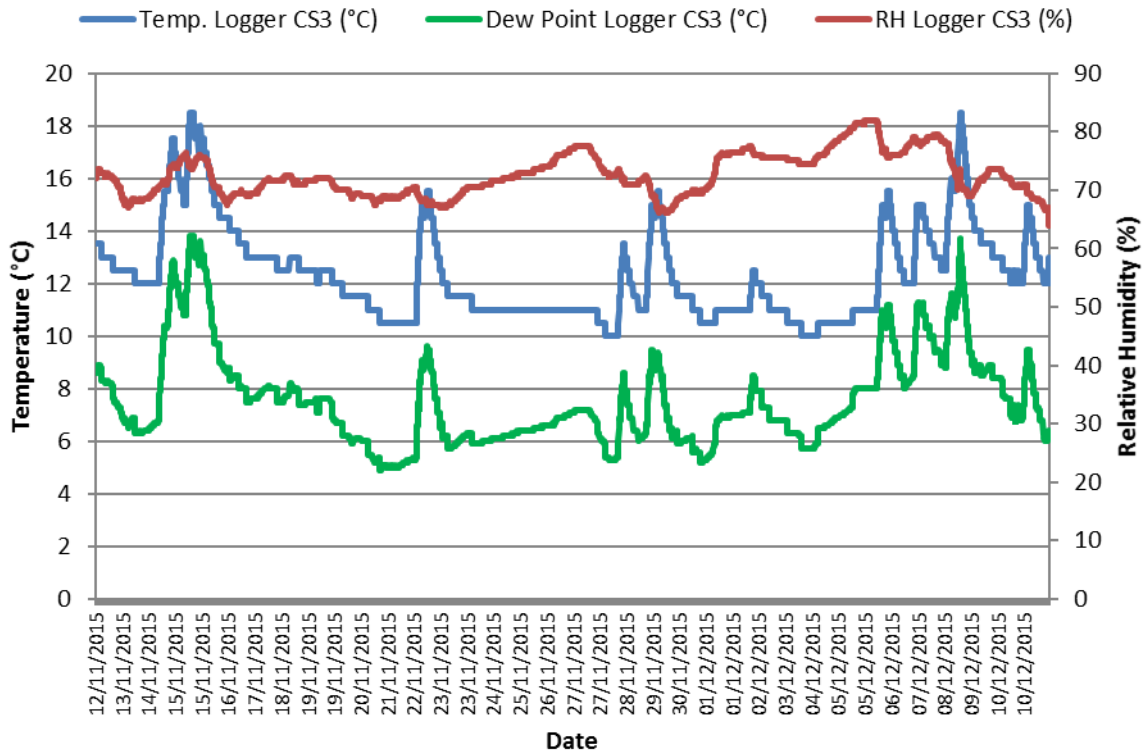

Logger CS4 St. Patrick's Armagh CI

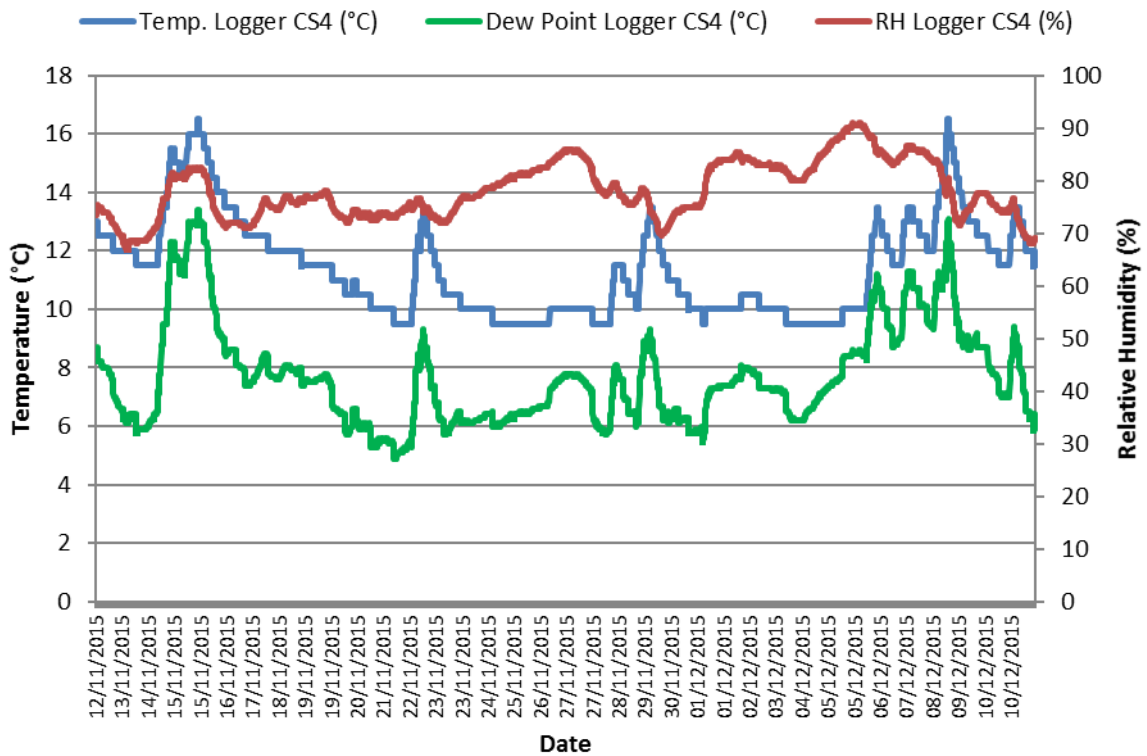

Logger CS5 St. Patrick's Armagh CI

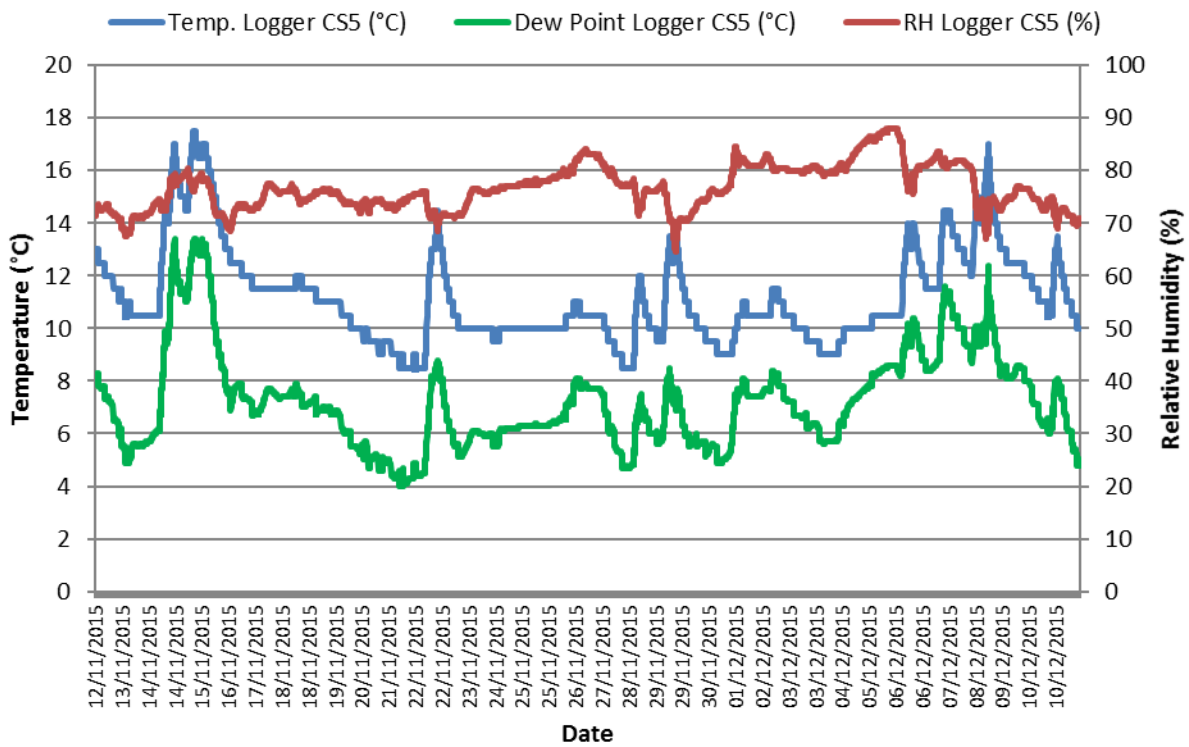

Appendix 12.3 – Tinytag graph (outside T and RH)

TT5Armagh

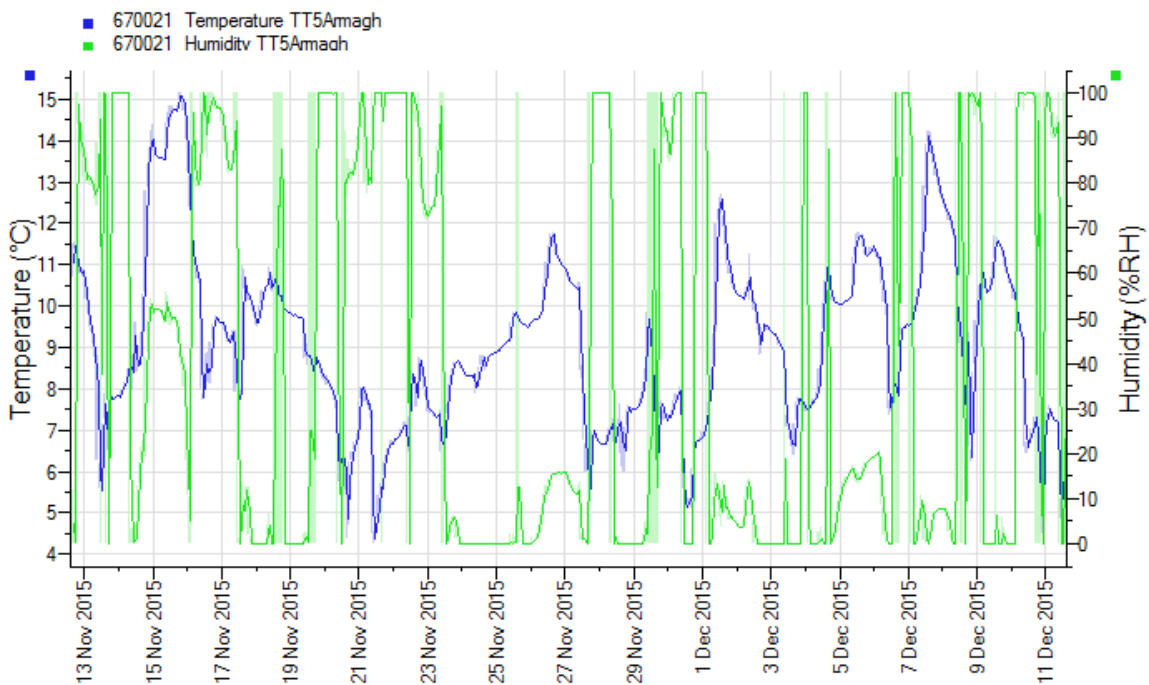

Appendix 13 - St. Peter's Roman Catholic Cathedral



Belfast

Name: The Cathedral Church of St. Peter.

Location: Belfast City, Northern Ireland

Tradition: Roman Catholic.

Outline history: St. Peter's cathedral is built in the gothic revival style and the building is situated in the heart of the Roman Catholic community off the falls Road in West Belfast. It is made of local Scrabo sandstone and is rather unusual in that there are no transepts. The original church was dedicated on the site in 1866 and for many years it was known as the Pro or temporary cathedral, although that title was never officially given to it by the Vatican. The spires on the church were completed in 1860 and the first pipe organ was installed in 1885. It was not officially dedicated as a cathedral until 1986 after the Bishop at the time, namely Bishop Daly petitioned Rome for this to happen. The present cathedral is surrounded by residential houses and apartments but it is a very heavily used building in common with other city centre cathedrals, with a constant stream of people coming in and out during the day for private devotions. The building has stone walls with plaster and painted internally. The ceiling is wooden with a complex structure in the nave but details of the void between the ceiling and the roof are not known. It appears however that in the side ailes there may be no void between the ceilings are roof in those areas. The floor is tile and there are a number of small side chapels. In common with all cathedrals the west door is protected with a lobby in an effort to reduce air ingress and egress.

Appendix 13.1 – floor plan with the loggers and TinyTag location

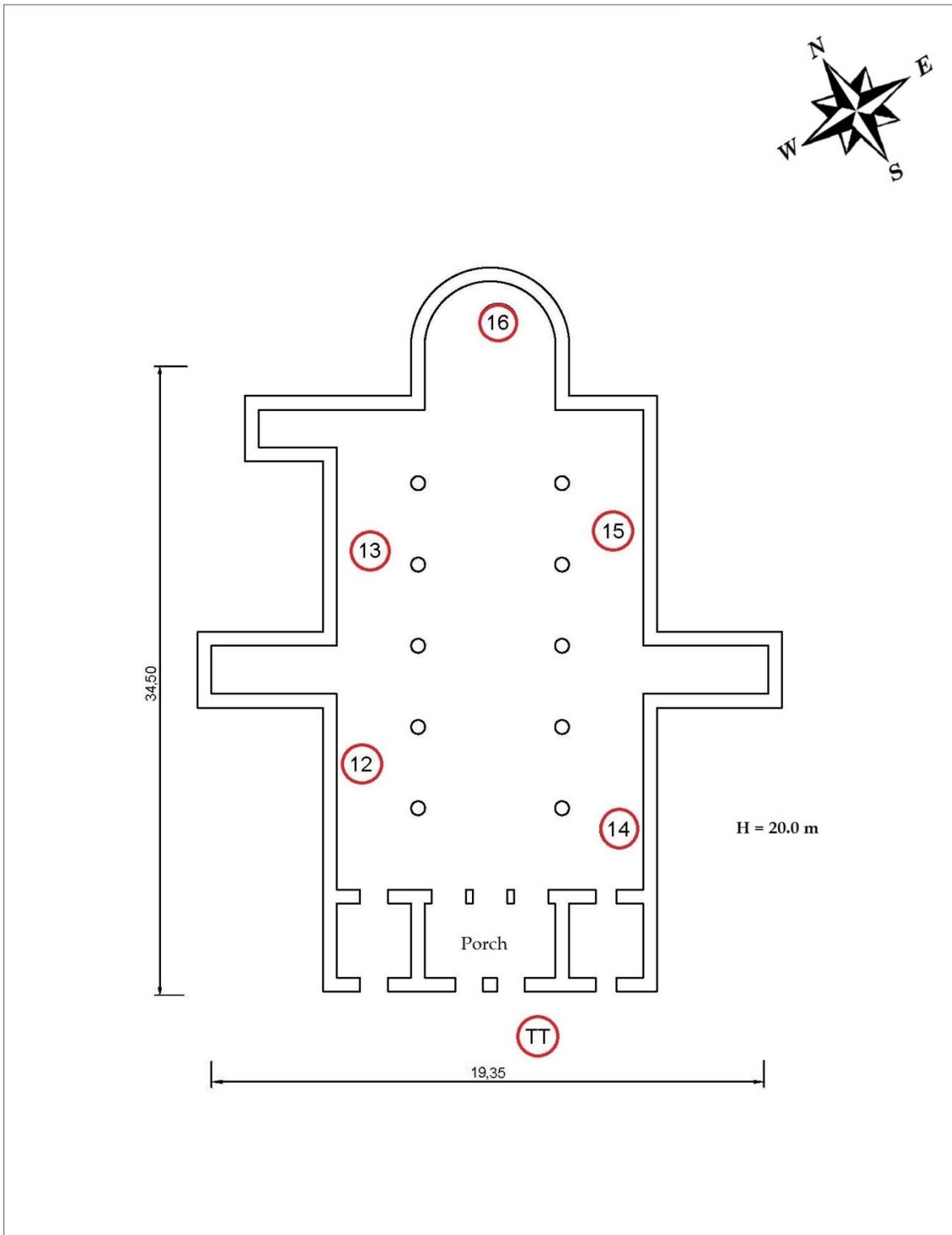

St. Peter's Cathedral	Size:	15,000 m ³
Belfast - Northern Ireland	Location:	54° 35' 57" N / 5° 56' 40" W
Roman Catholic Church	Heating type:	Underfloor

Appendix 13.2 – Loggers' graphs

Logger 12 St. Peter's Belfast

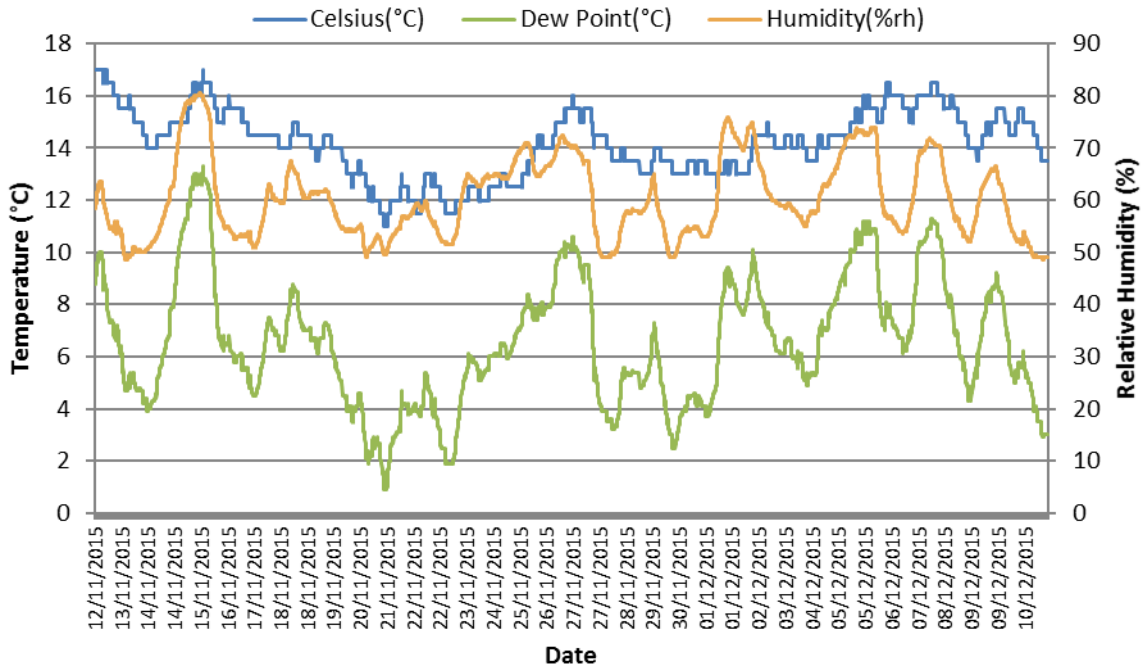

Logger13 St. Peter's Belfast

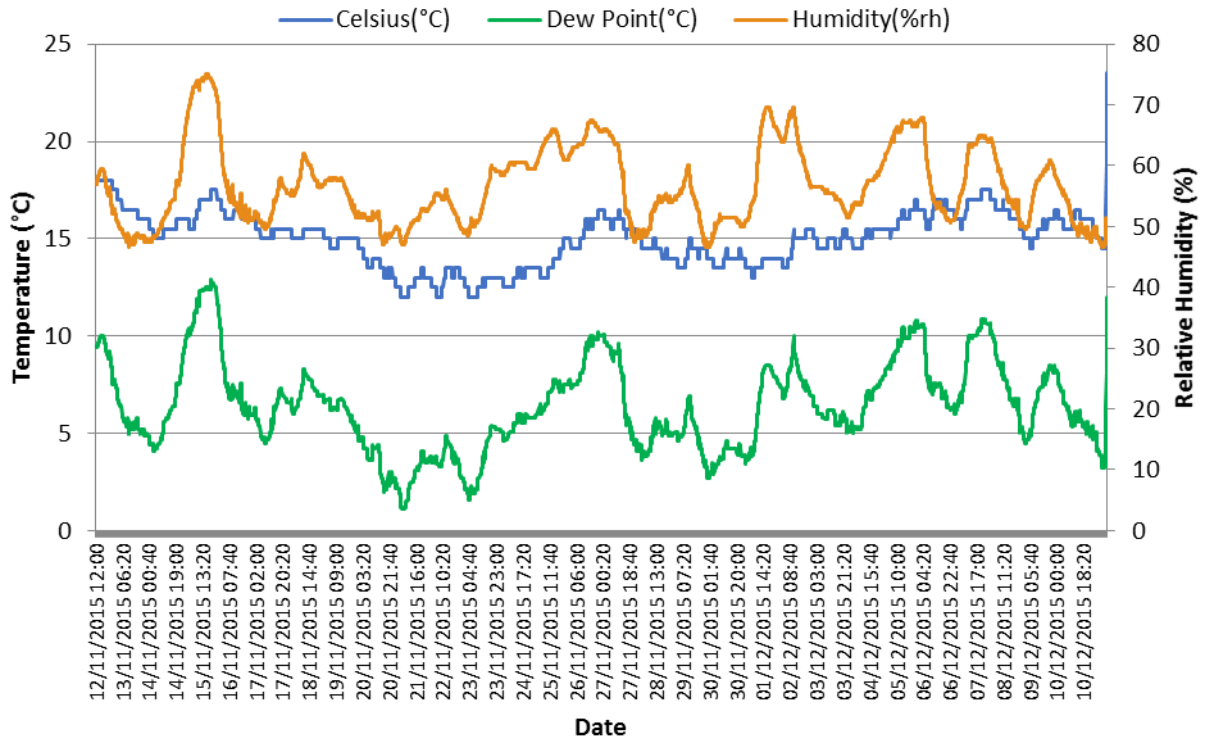

Logger 14 St. Peter's Belfast

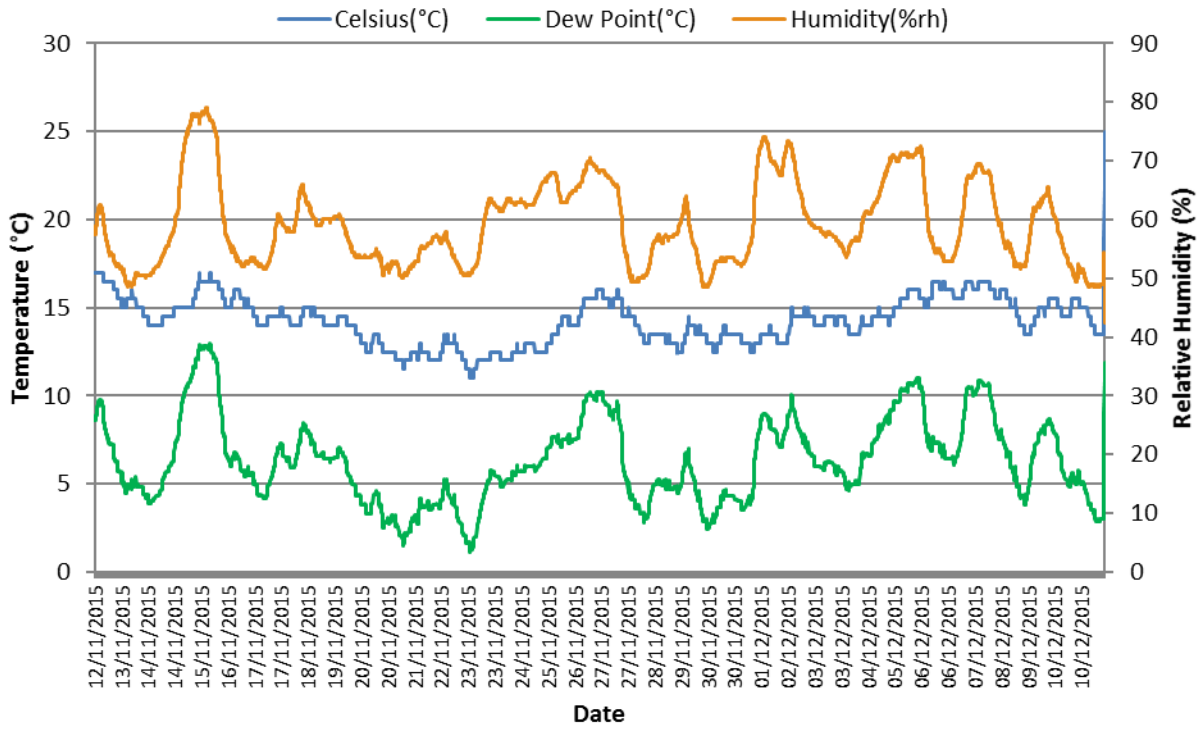

Logger 15 St. Peter's Belfast

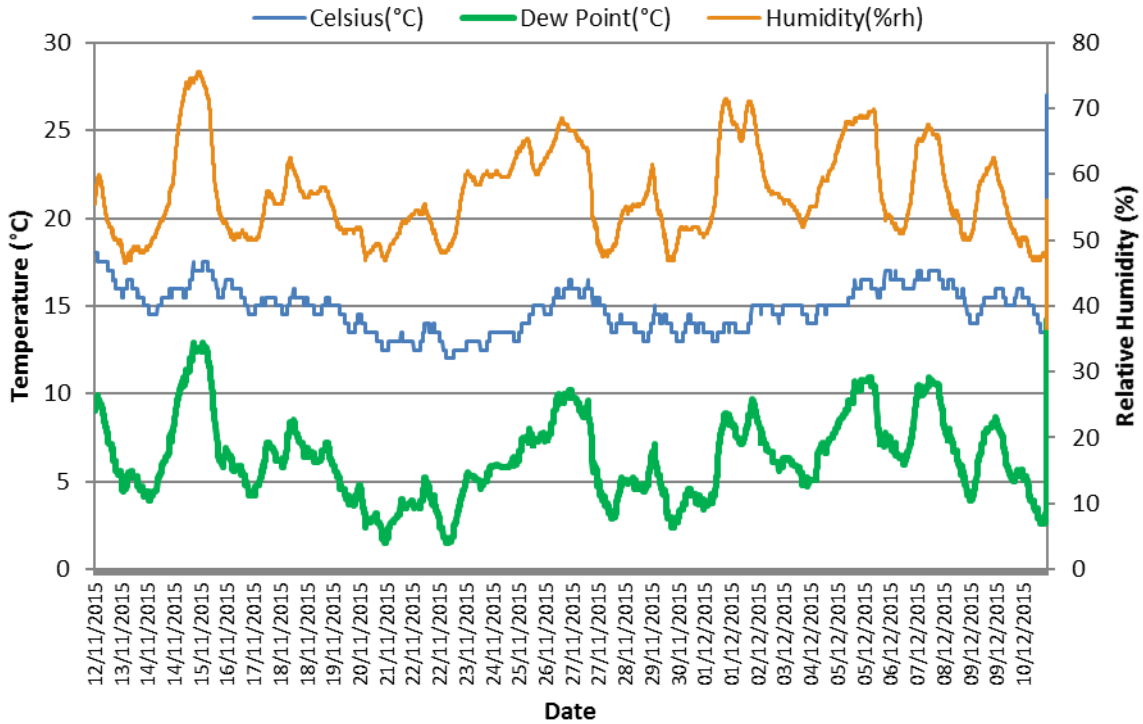

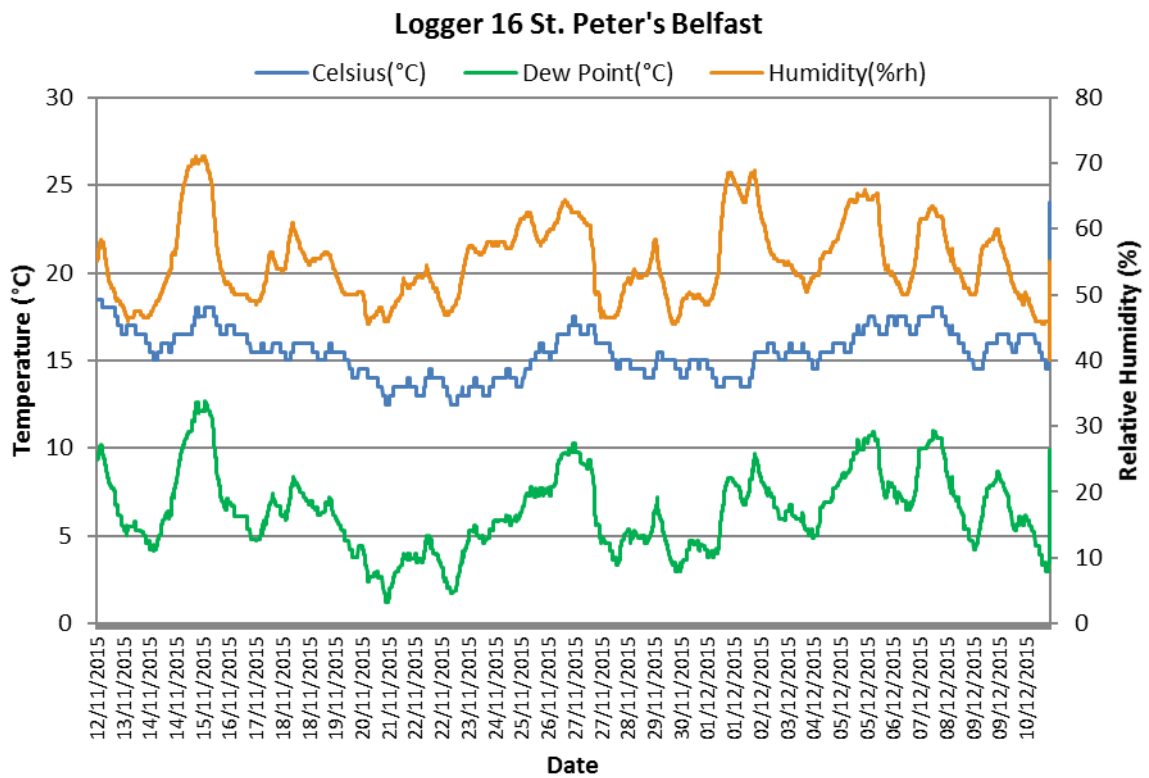

Appendix 13.3 – Tinytag graph

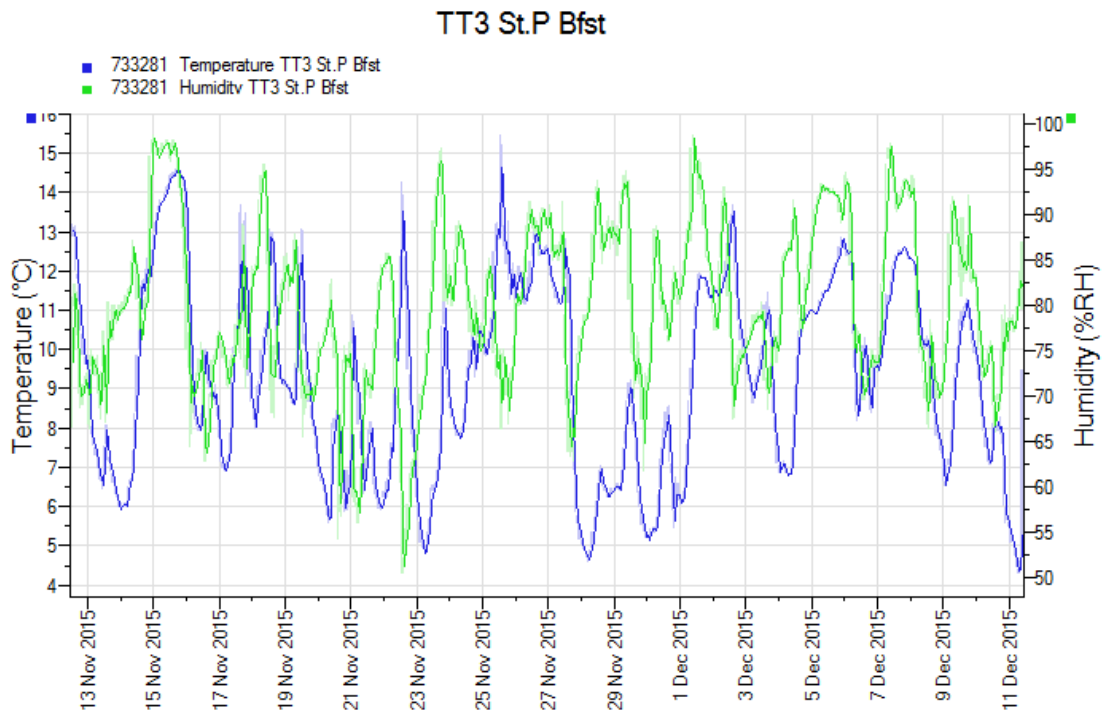

Appendix 14 – St. Fin Barre’s Church of Ireland Cathedral



Cork

Name: The Cathedral Church of St. Fin Barre

Location: Cork City, Republic of Ireland

Tradition: Church of Ireland

Outline history: St. Fin Barre is reputed to have arrived in Cork in circa 606 where he founded a monastery. He died in circa 623 and is reported to be buried in the grounds of the present cathedral but the exact location is not known. Little is known or recorded of the mediaeval cathedral which was built but it was demolished in 1785. The replacement was not a success and it too was demolished in 1860 to make way for the present cathedral. A competition was launched to find a designer of the new cathedral and the competition was won by a William Burgess from London. The budget set for the cathedral was £15,000 but the ultimate cost was £100,000 much to the annoyance of the competitors for the commission. The present cathedral is French Gothic in design and includes some of the finest stained glass windows in Ireland. The organ is unusual in that the organ pipes are below ground level. The cathedral is the cathedral of the Church of Ireland Diocese of Cork, Cloyne and Ross and it is widely accepted that St. Fin Barre's is one of the finest looking cathedrals owned by the Church of Ireland. This is a cruciform cathedral with nave and side aisles. The ceiling is wooden but it is not known if the void between the roof and ceiling is insulated. The walls are stone with some internal mosaics. The floor is stone but the area under the wooden pews is wooden.

Appendix 14.1 – Floor plan with loggers and TinyTag location

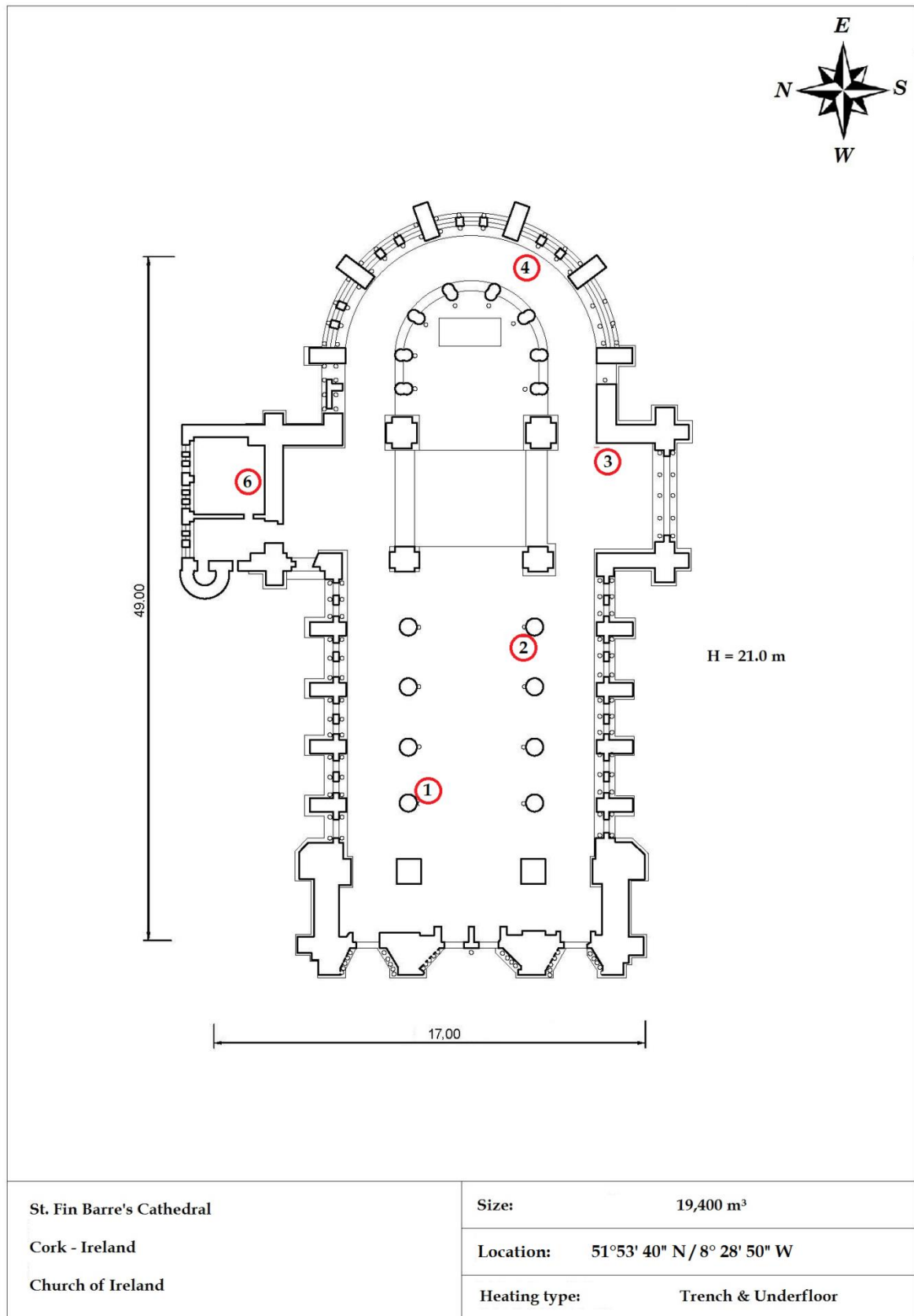

Appendix 14.2 – Loggers' graphs

Logger 1 St. Fin Barre's Cork

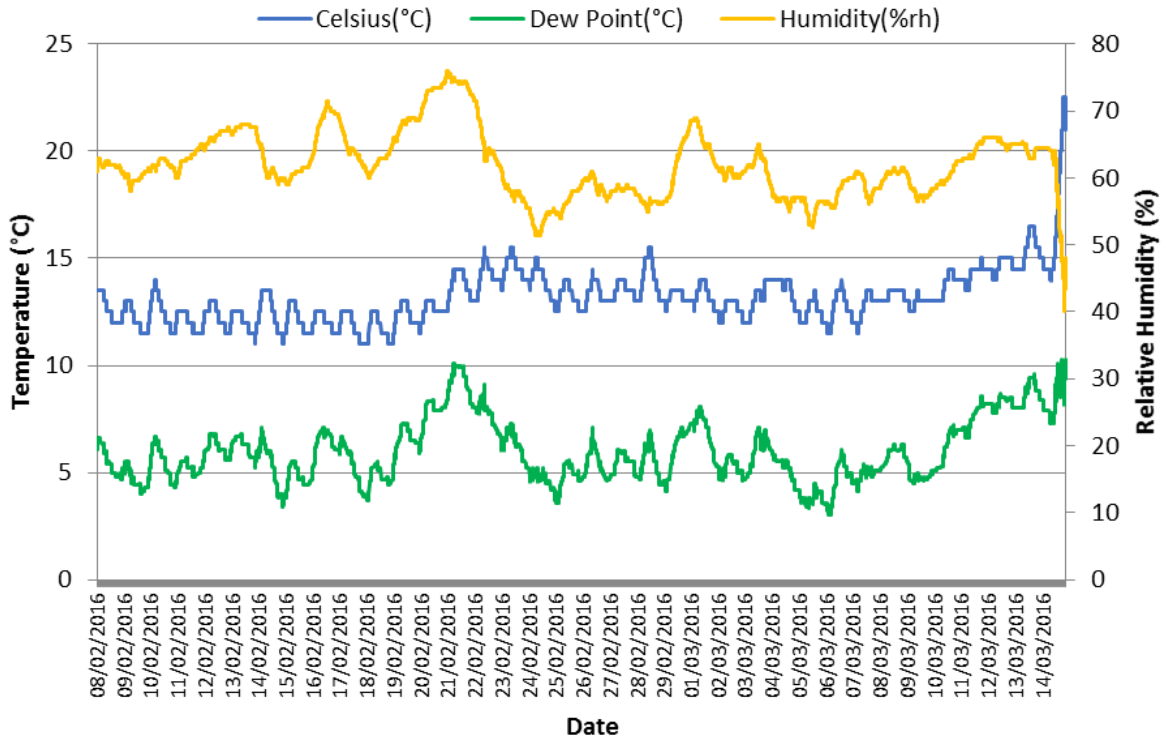

Logger 2 St. Fin Barre's Cork

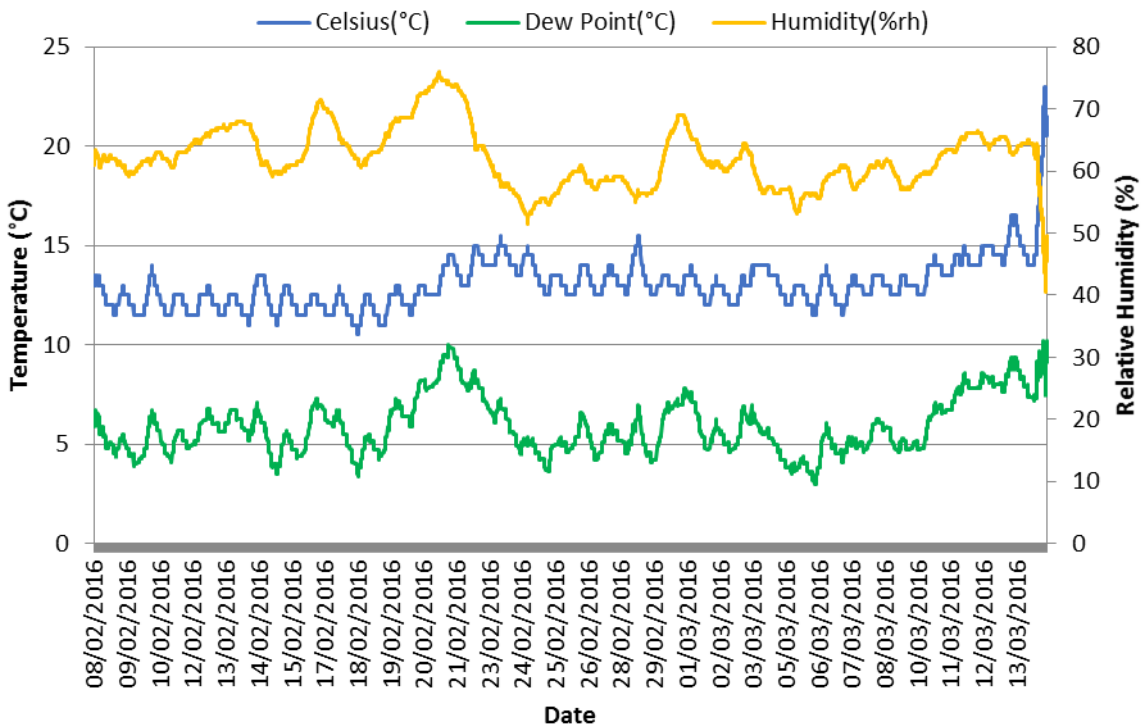

Logger 3 St. Fin Barre's Cork

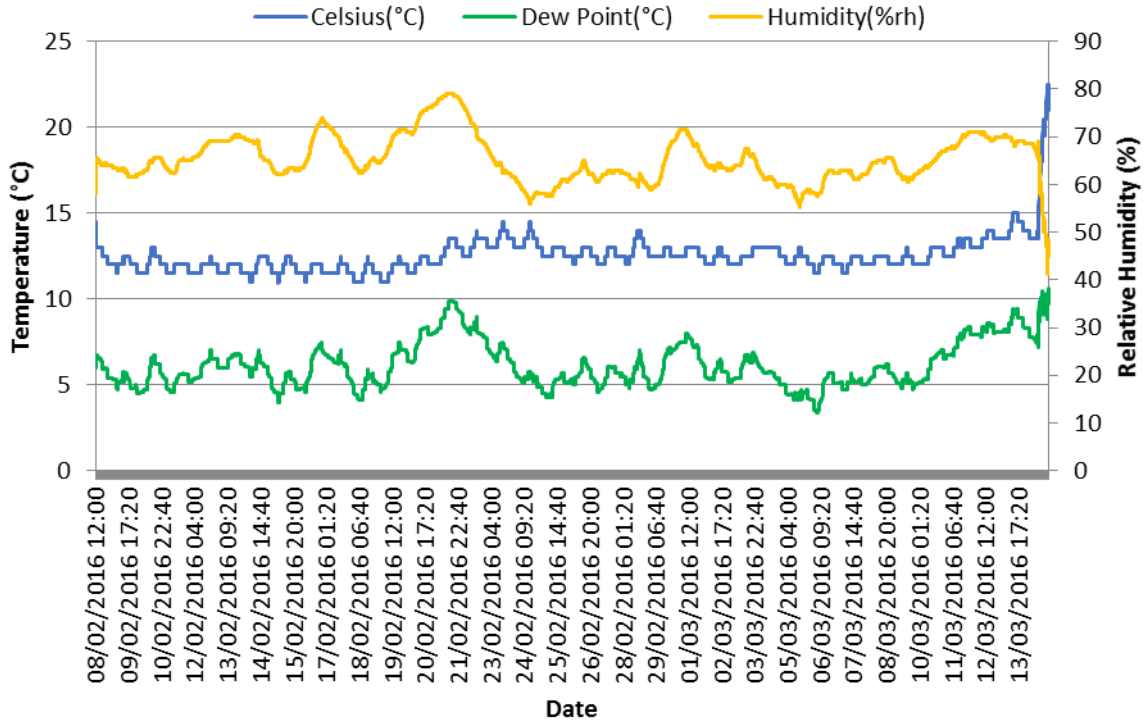

Logger 4 St. Fin Barre's Cork

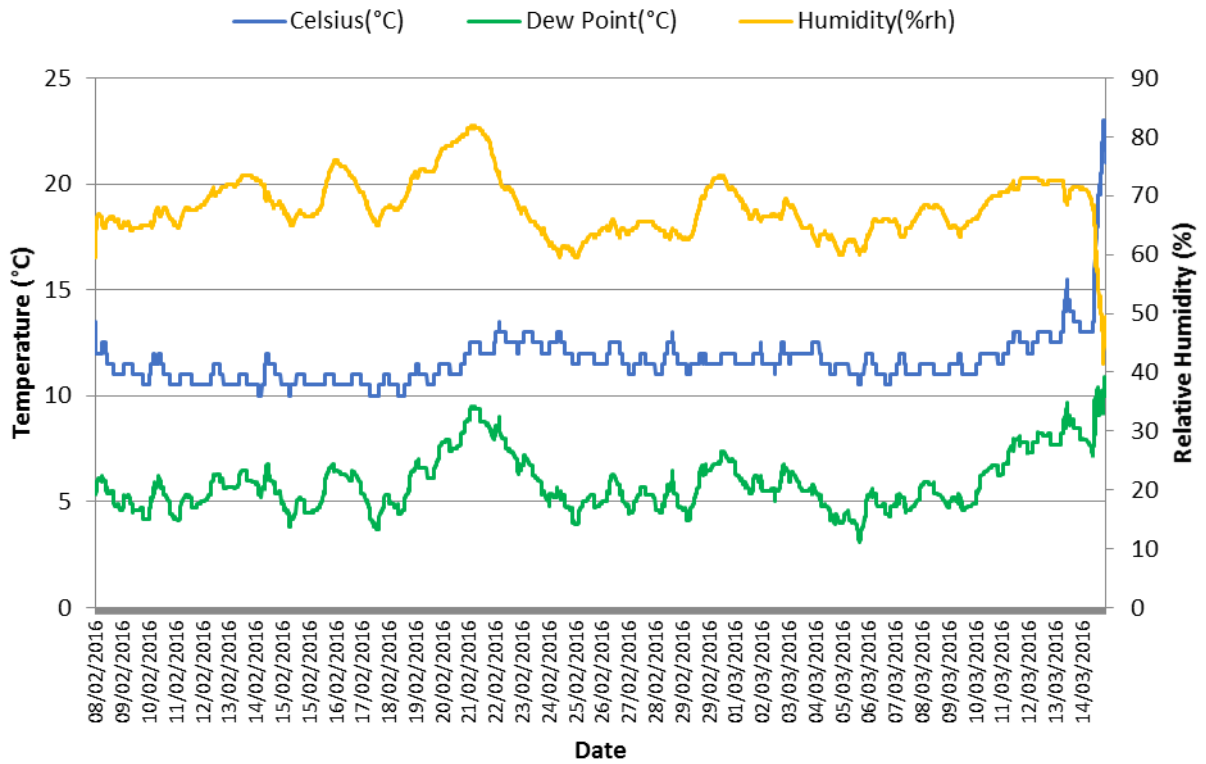

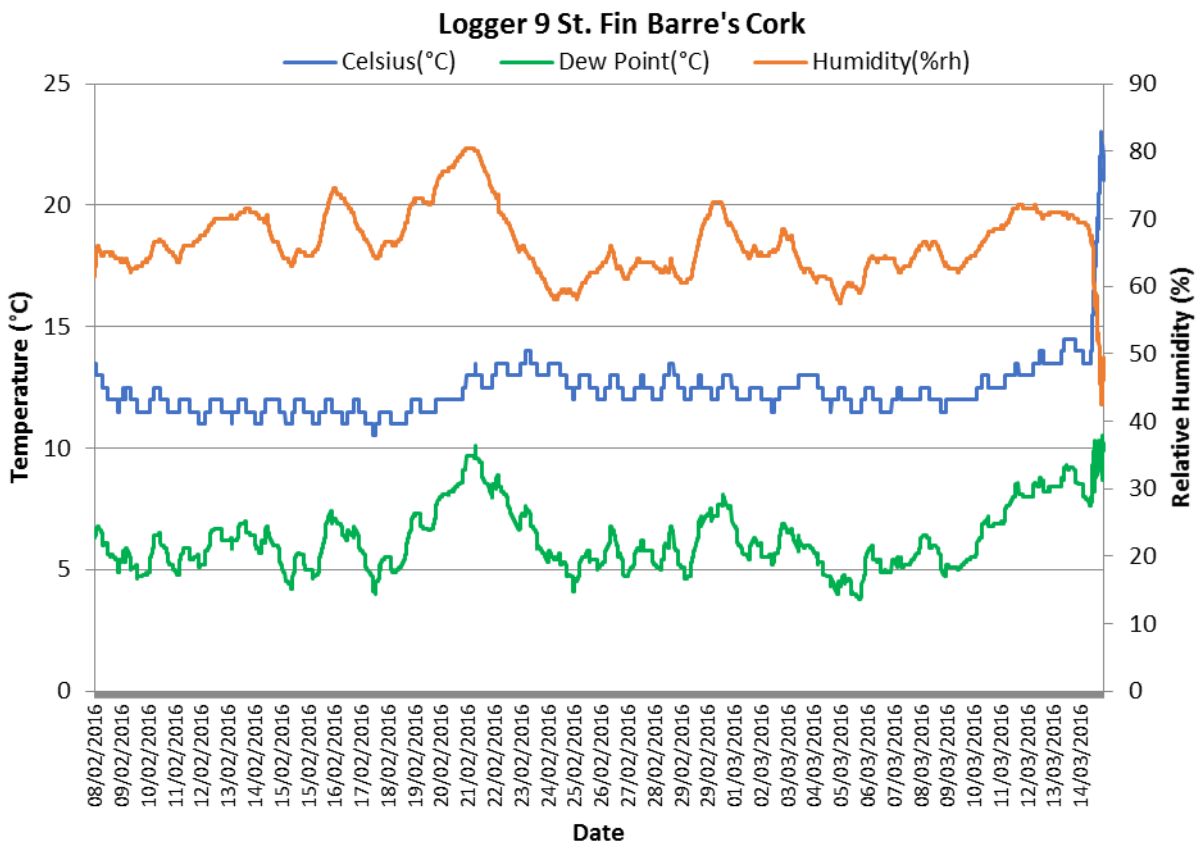

Appendix 14.3 – Tinytag graph (outside T and RH)

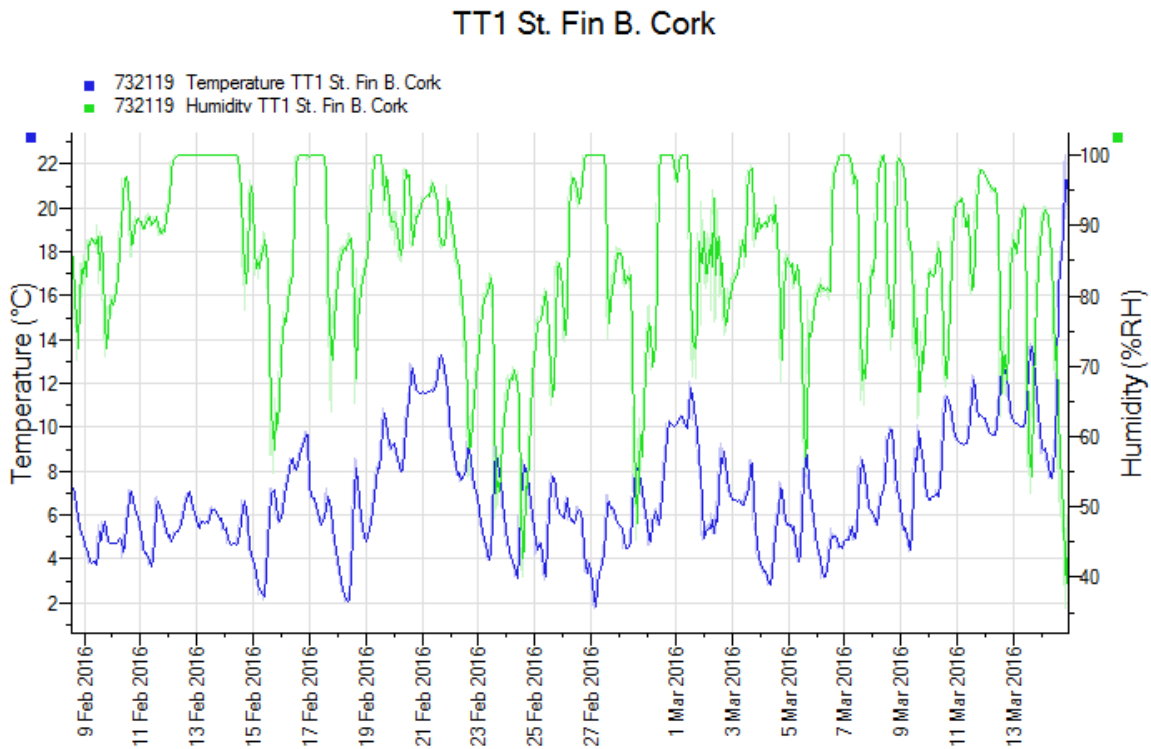

Appendix 15 – The Cathedral Church of the Holy Trinity, Church of Ireland



Dublin

Name: The Cathedral Church of the Holy Trinity. (Commonly called Christ Church Cathedral).

Location: Dublin City, Republic of Ireland.

Tradition: Church of Ireland

Outline history: The first cathedral was built on the present site in circa 1030 by Dunan the first Bishop of Dublin and Sitric the first Viking leader. In 1152 Archbishop Laurence O'Toole was appointed and he was later to become the Patron Saint of Dublin. Under his reforms the cathedral became an Augustinian Priory which it remained until the Reformation (1517-1648). When the Anglo Normans captured Dublin in 1170 Archbishop O'Toole negotiated with the Norman leader Strongbow whose tomb is now in the cathedral. St. Laurence O'Toole's heart was also in the cathedral until it was stolen a few years ago. In 1562 the nave roof collapsed and Strongbow's tomb was destroyed. To this day the North wall of the nave leans outwards by 18 inches. In 1690 King William III, after his victory at the Battle of the Boyne over the English King James II, gave the cathedral a set of gold communion plate which can be seen today in the treasury exhibition in the crypt of the cathedral. The cathedral was extensively rebuilt in the late 1800s by the architect George Edmund Street and the work was financed by a Dublin whisky distiller named Henry Roe. Further extensive work was carried out in 1982 and a new organ was installed in 1984. Many famous civic, cultural and ecclesiastical events have taken place in the cathedral over the years. This is a cruciform cathedral with side aisles and chapels. The floor is tiled and the roof and walls are stone. The void between the roof and ceiling is not insulated.

Appendix 15.1A – Floor plan with the loggers and TinyTag location

(A) SUMMER

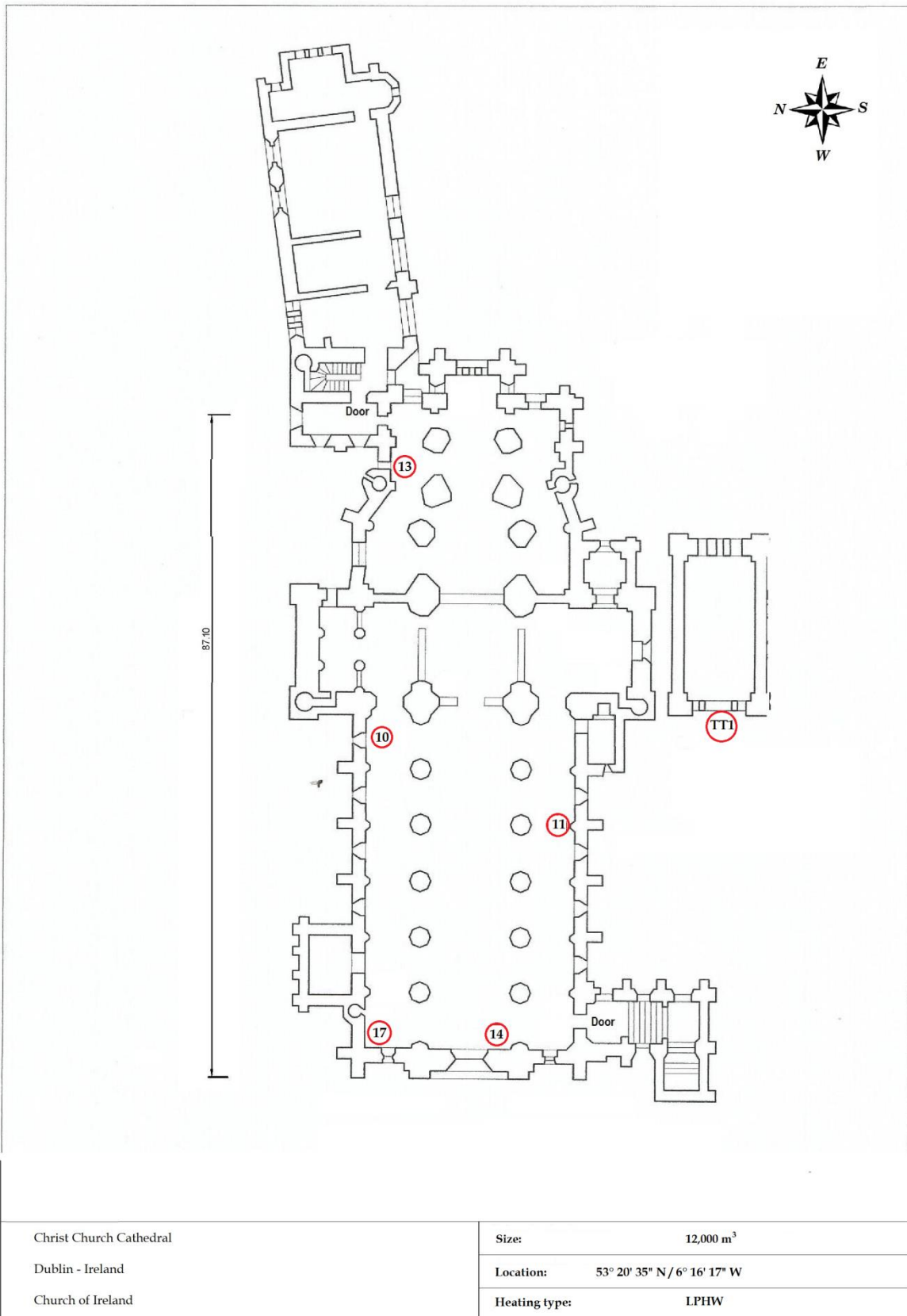

Appendix 15.2A – Loggers' graphs

Logger 10 CCC - Summer

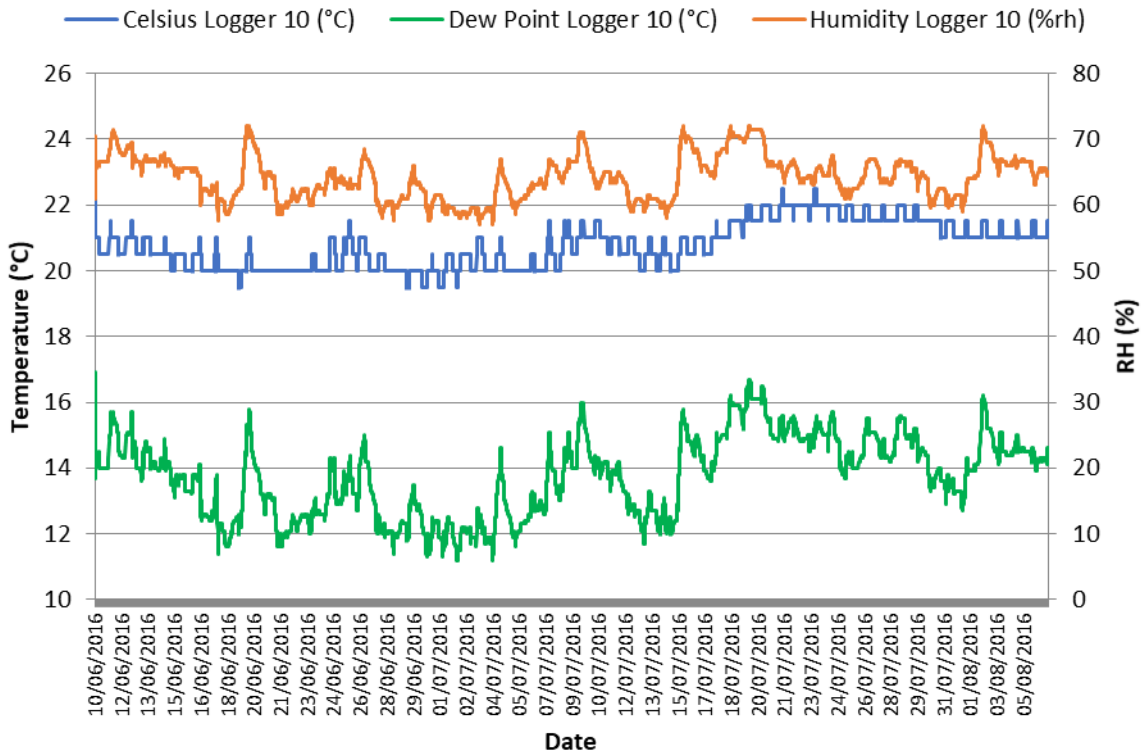

Logger 11 CCC - Summer

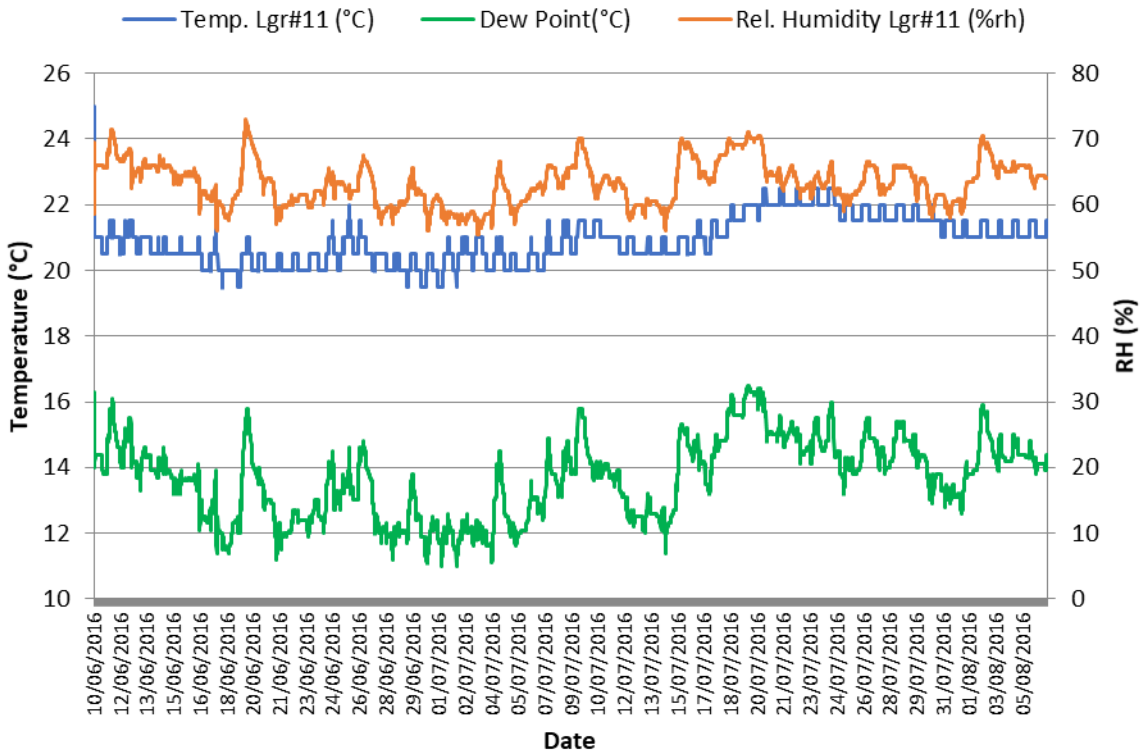

Logger 13 CCC - Summer

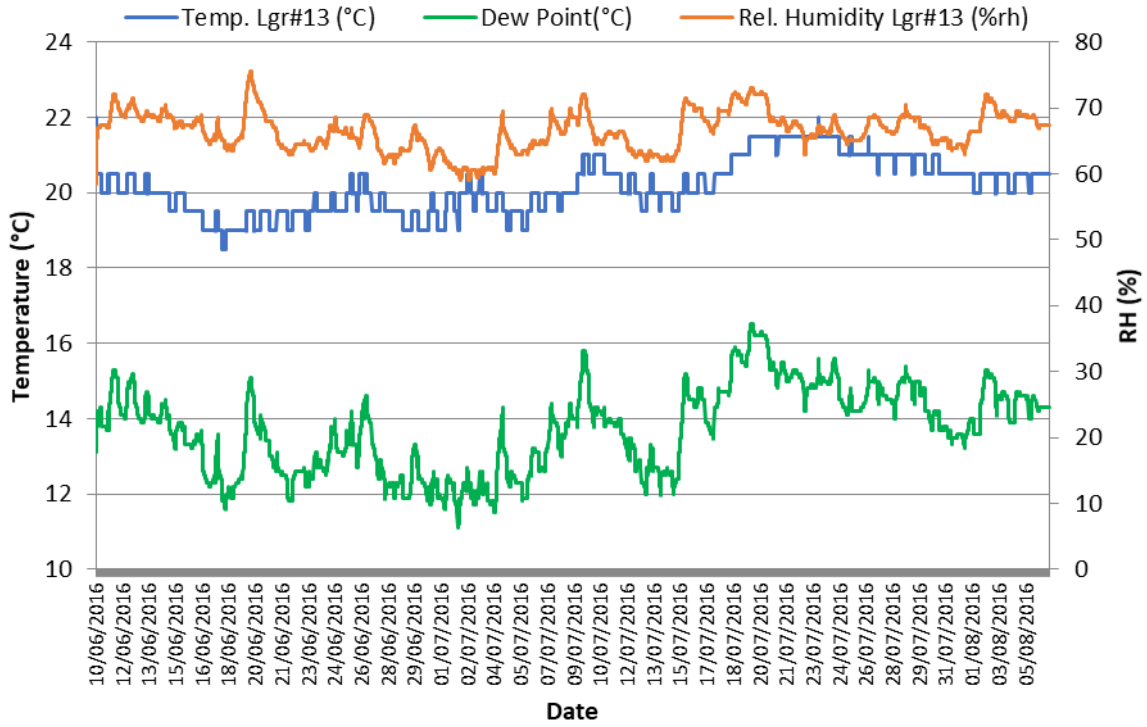

Logger 14 CCC - Summer

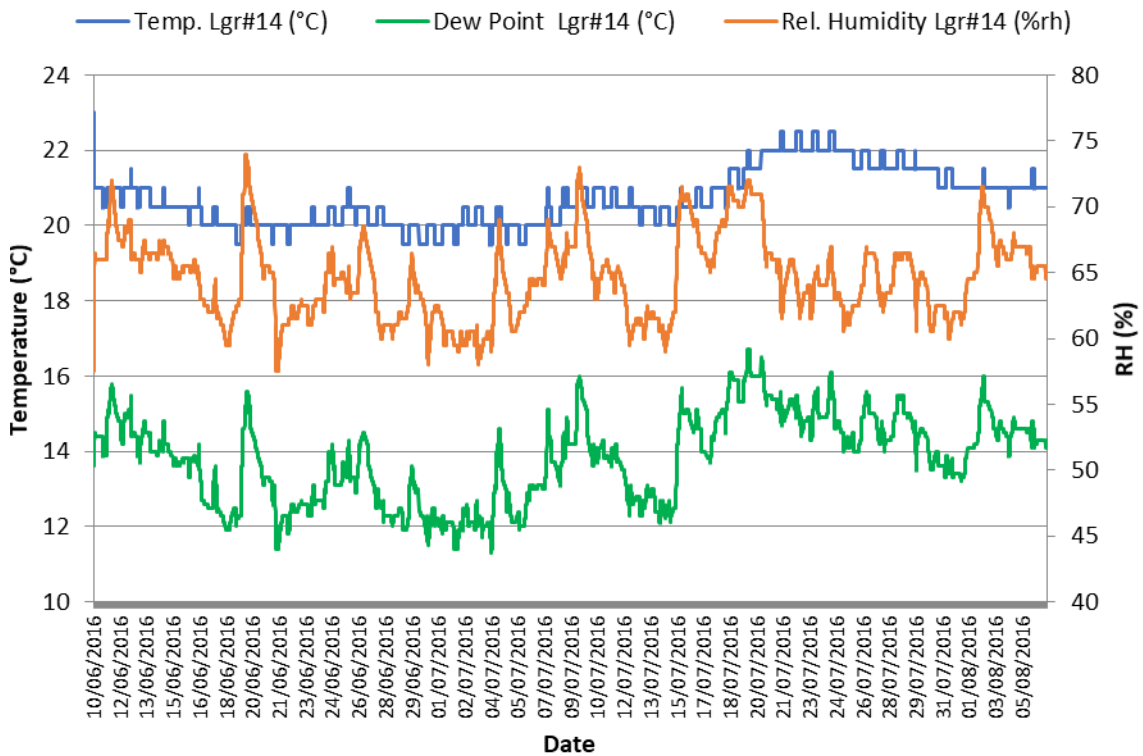

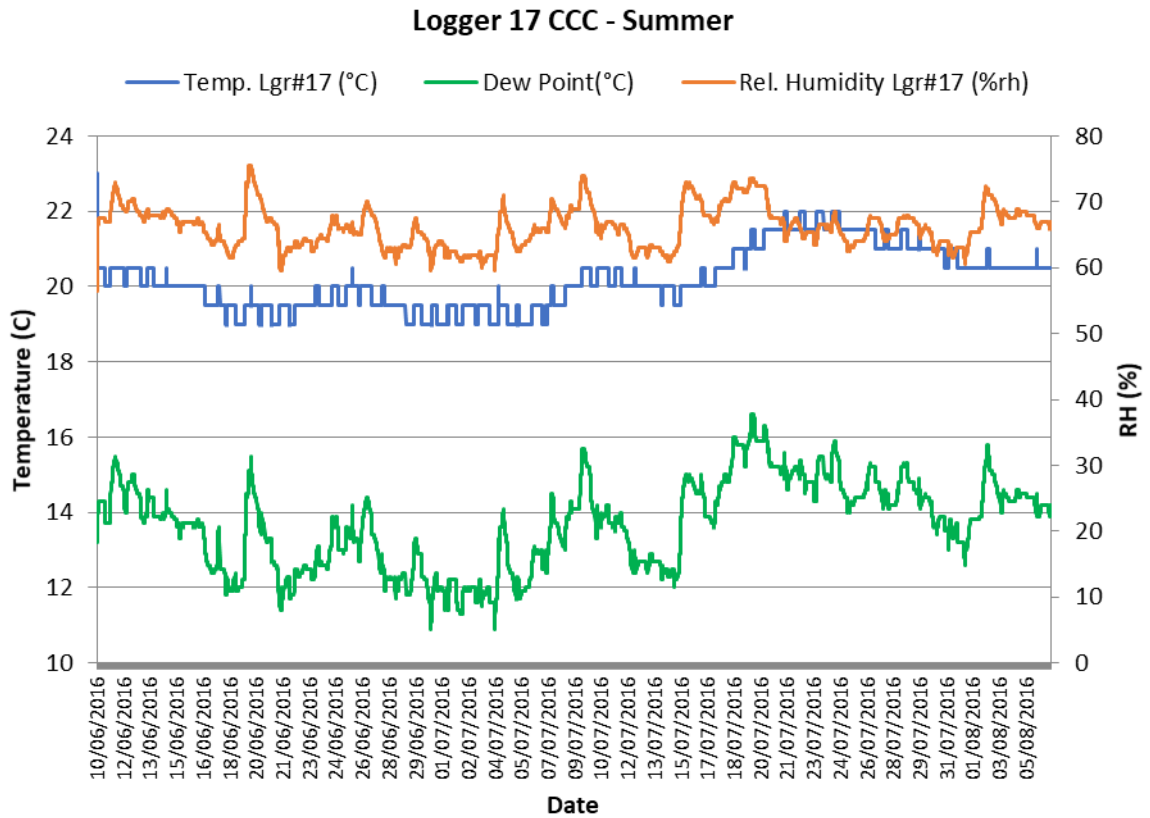

Appendix 15.3A – Tinytag graph

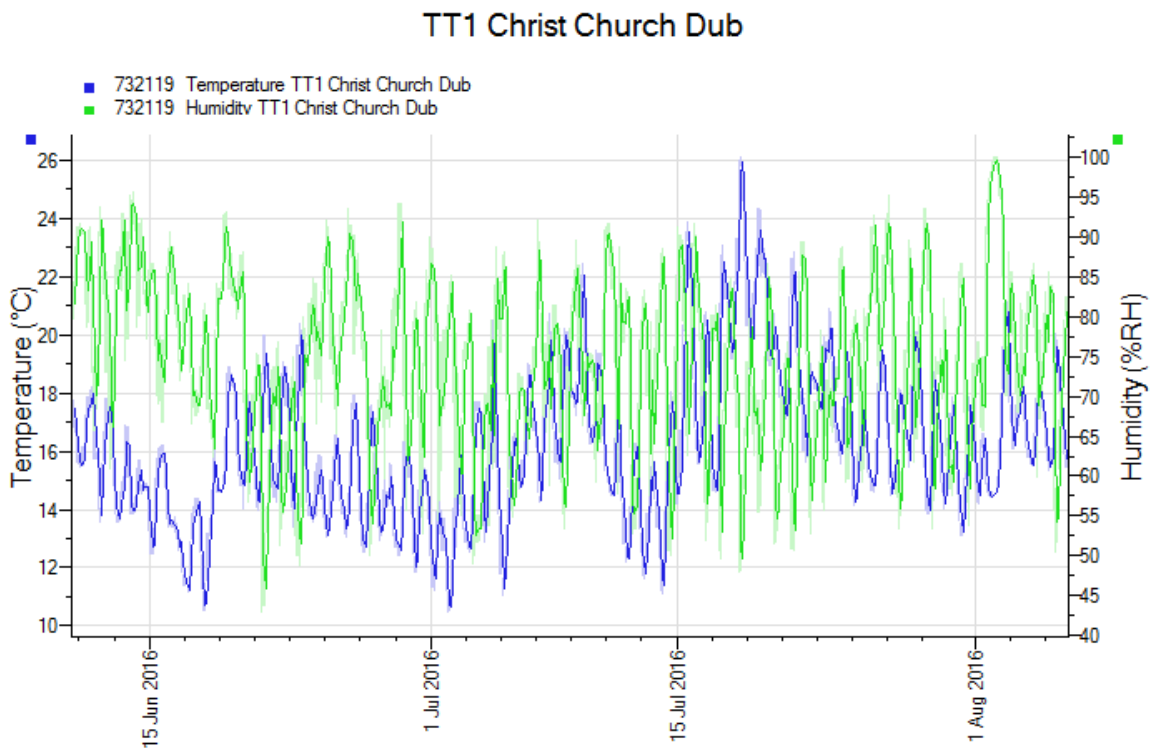

Appendix 15.1B – Floor plan with the loggers and TinyTag location

(B) WINTER

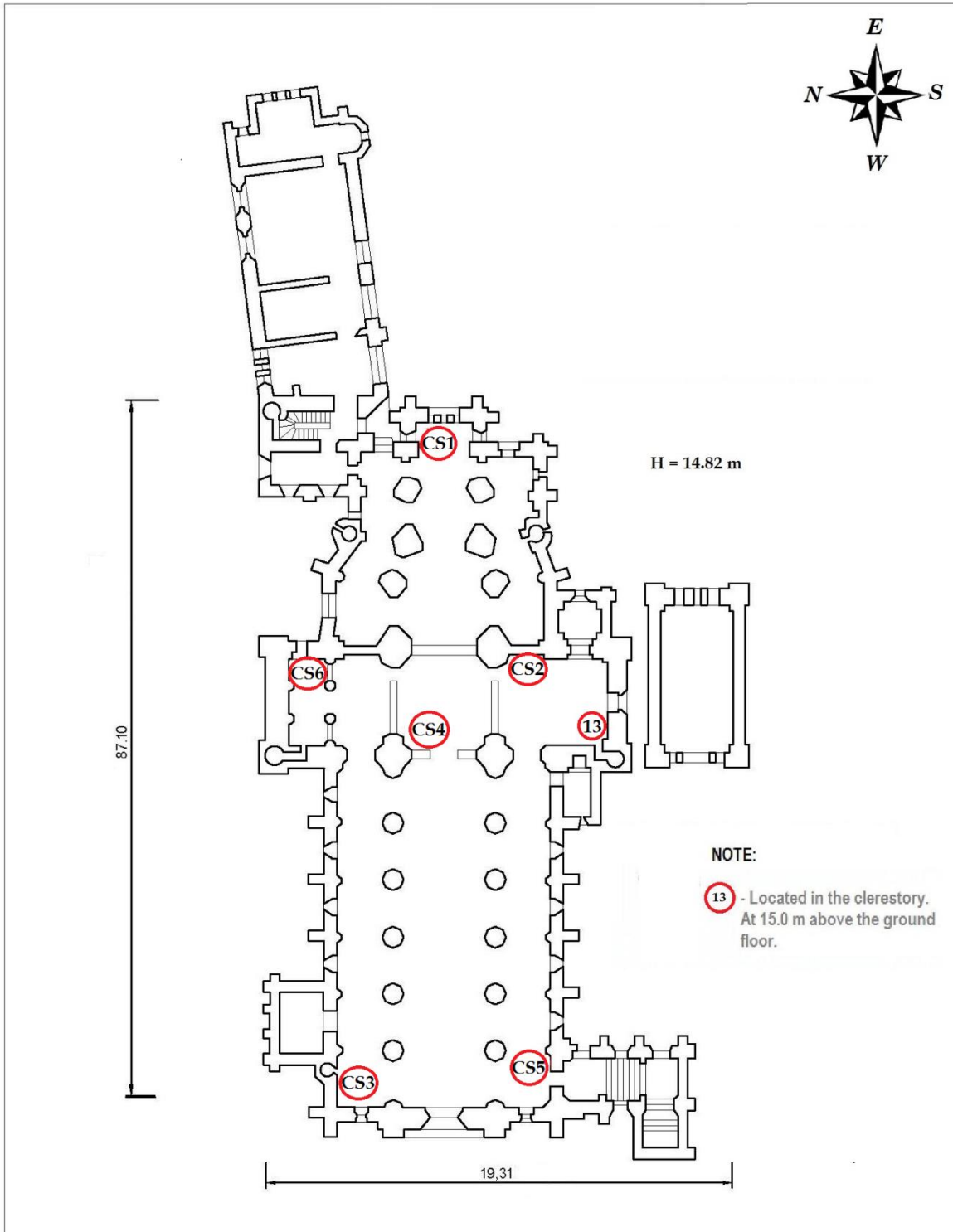

Christ Church Cathedral Winter Dublin - Ireland Church of Ireland	Size:	12,000 m ³
	Location:	53° 20' 35" N / 6° 16' 17" W
	Heating type:	LPHW

Appendix 15.2B – Loggers' graphs

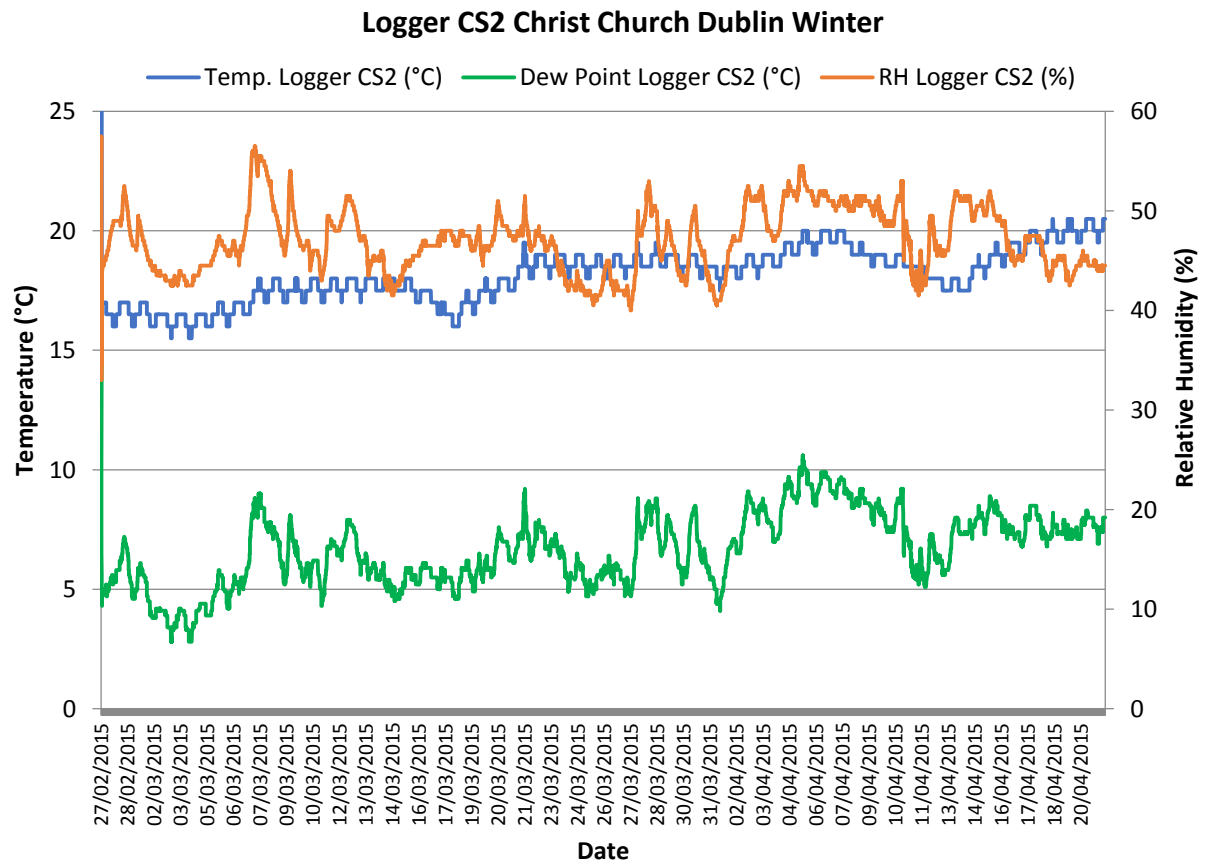
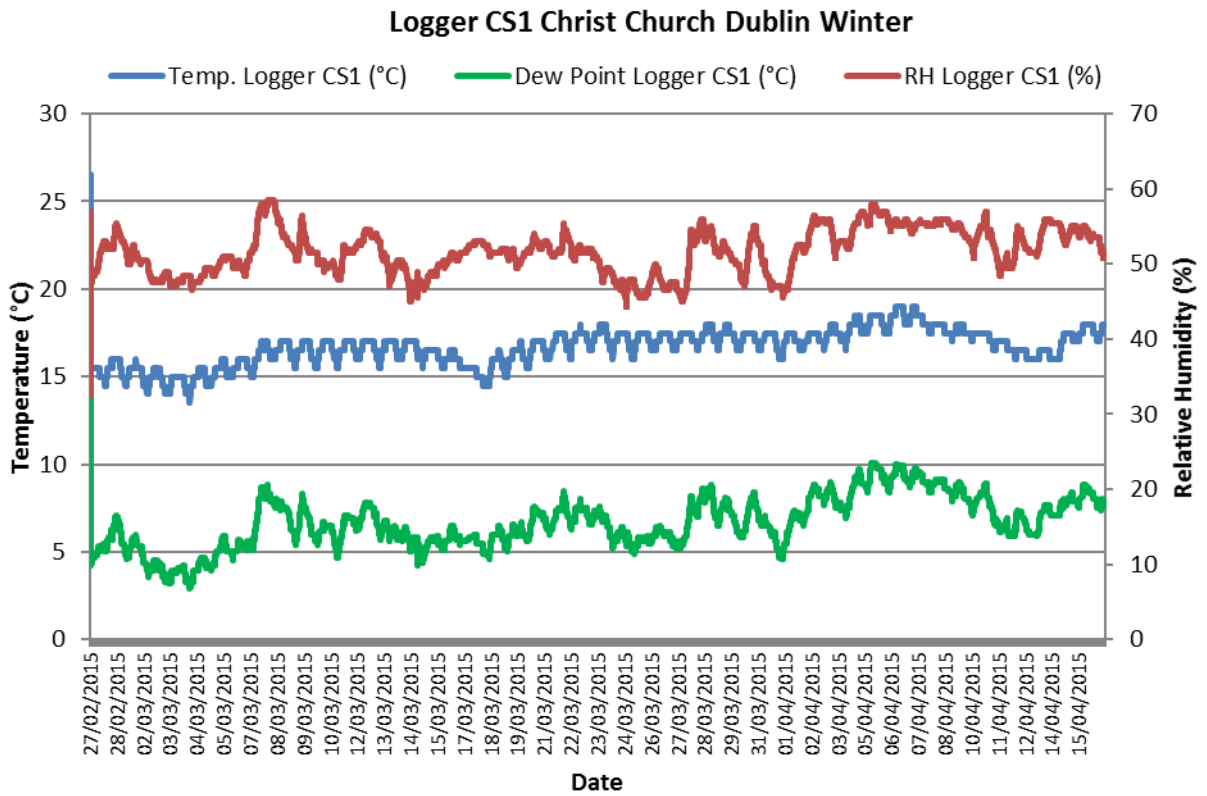

Logger CS3 Christ Church Dublin Winter

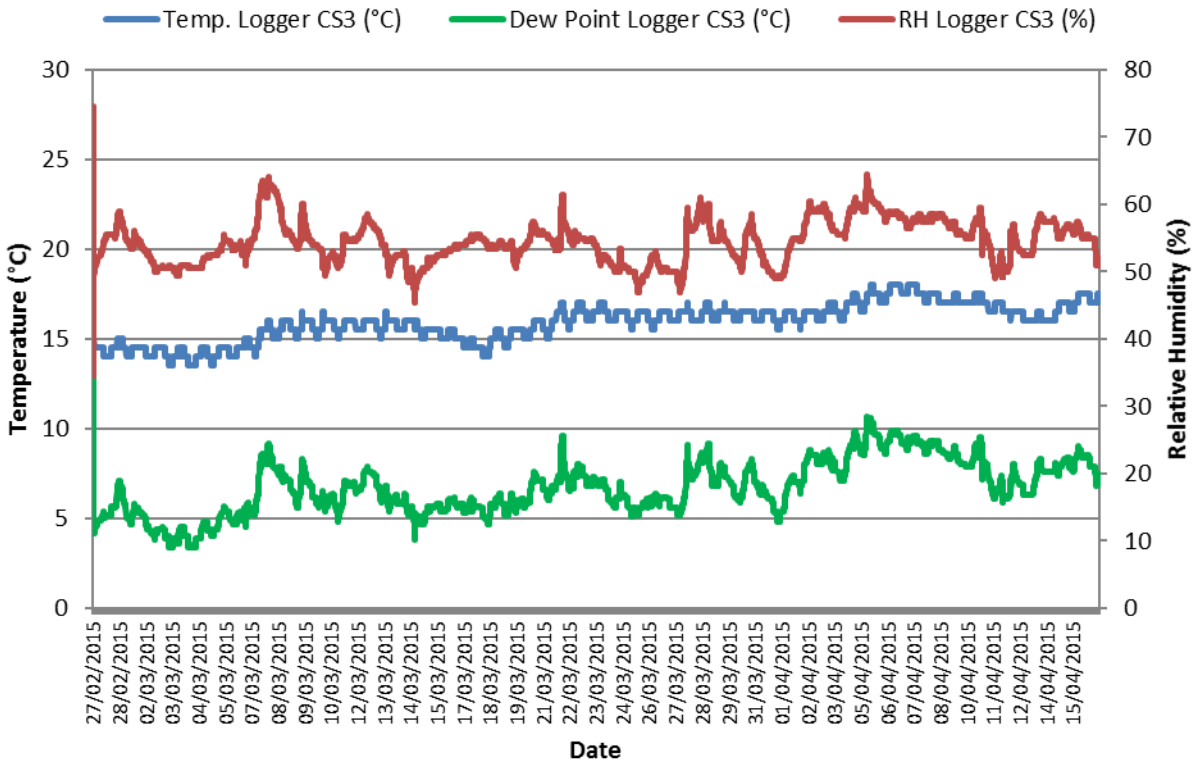

Logger CS4 Christ Church Dublin Winter

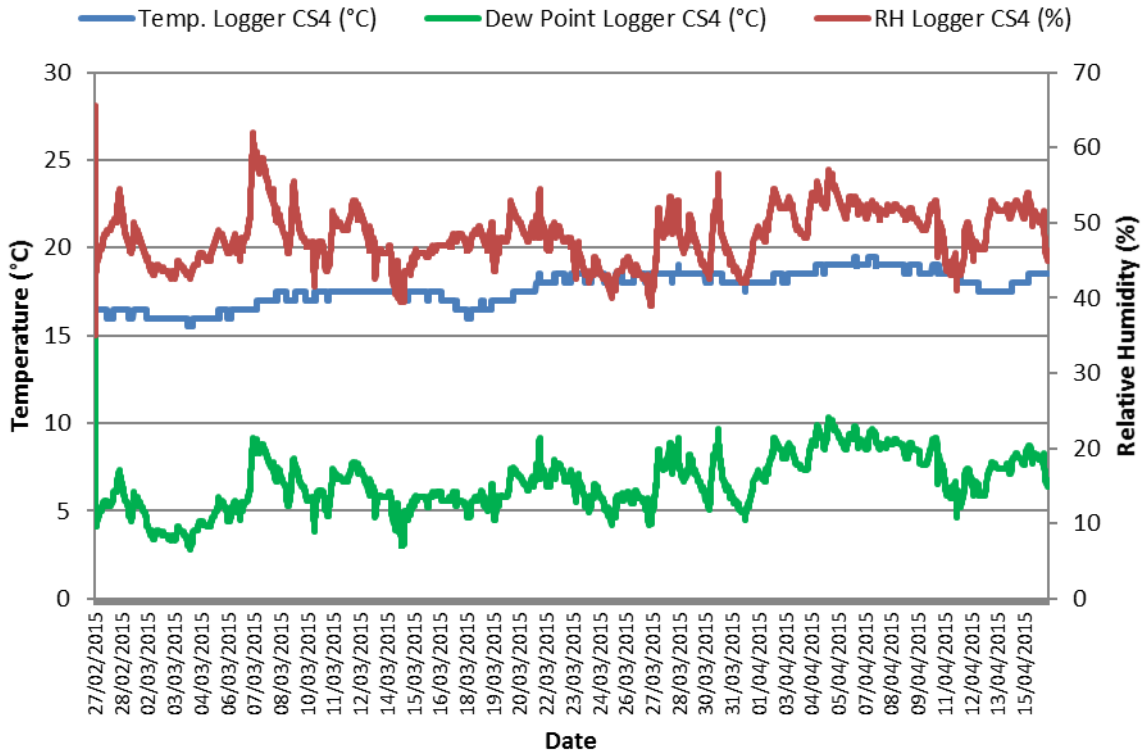

Logger CS5 Christ Church Dublin Winter

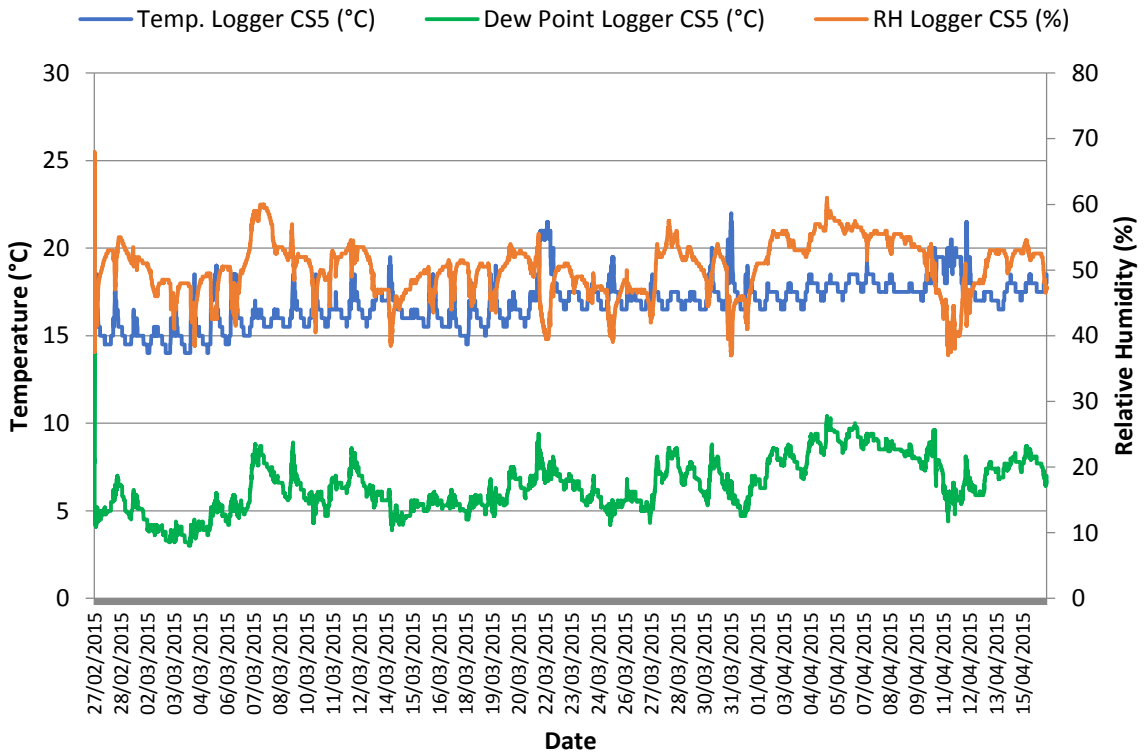

Logger CS6 Christ Church Dublin Winter

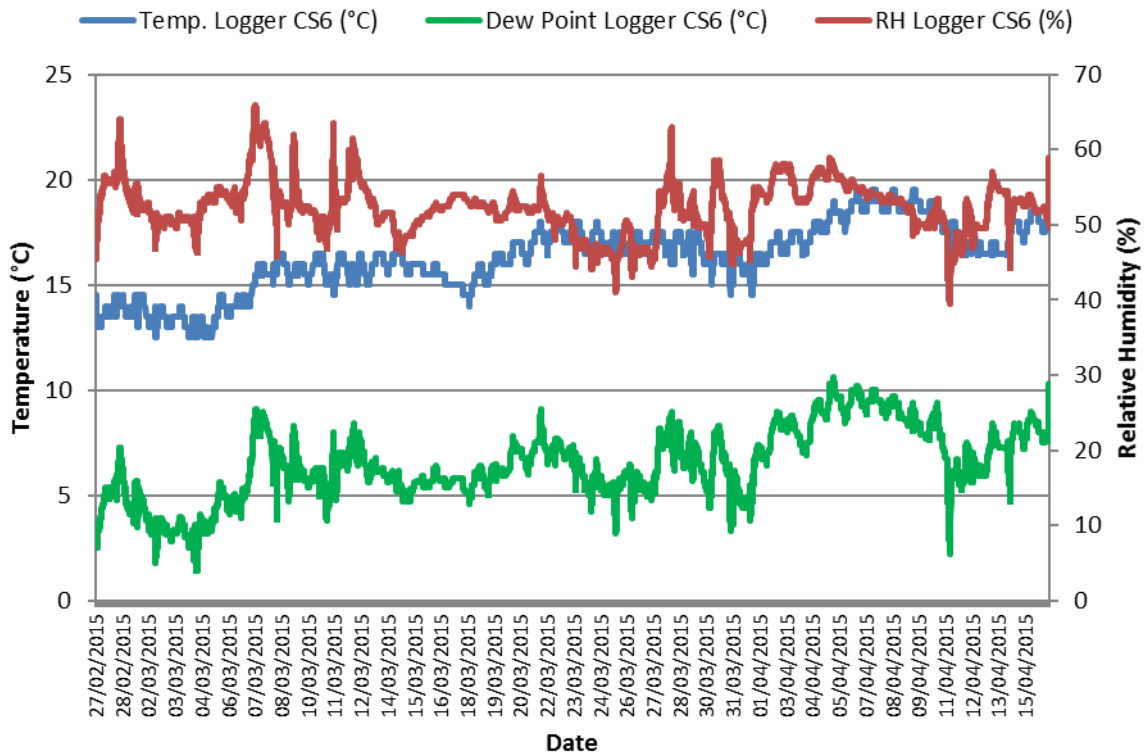

Logger 13 Christ Church Dublin Winter

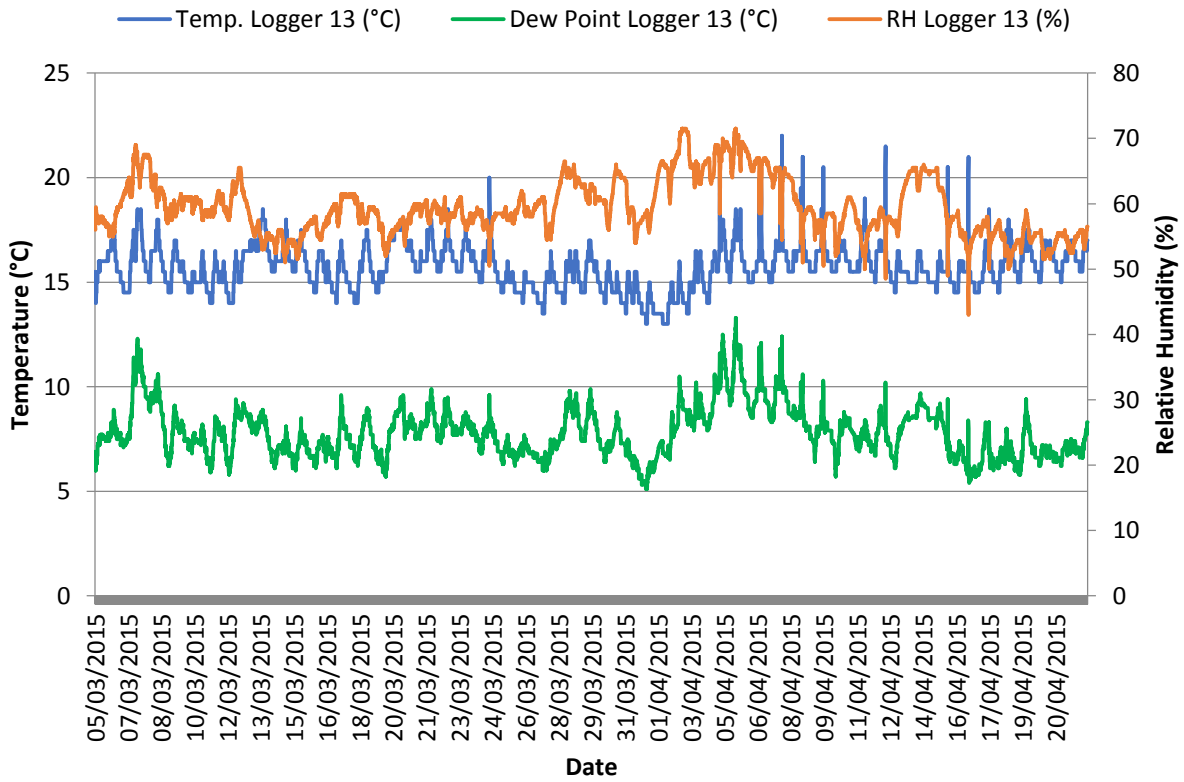

Appendix 15.3B – Tinytag graph

TT1 CCC Dub

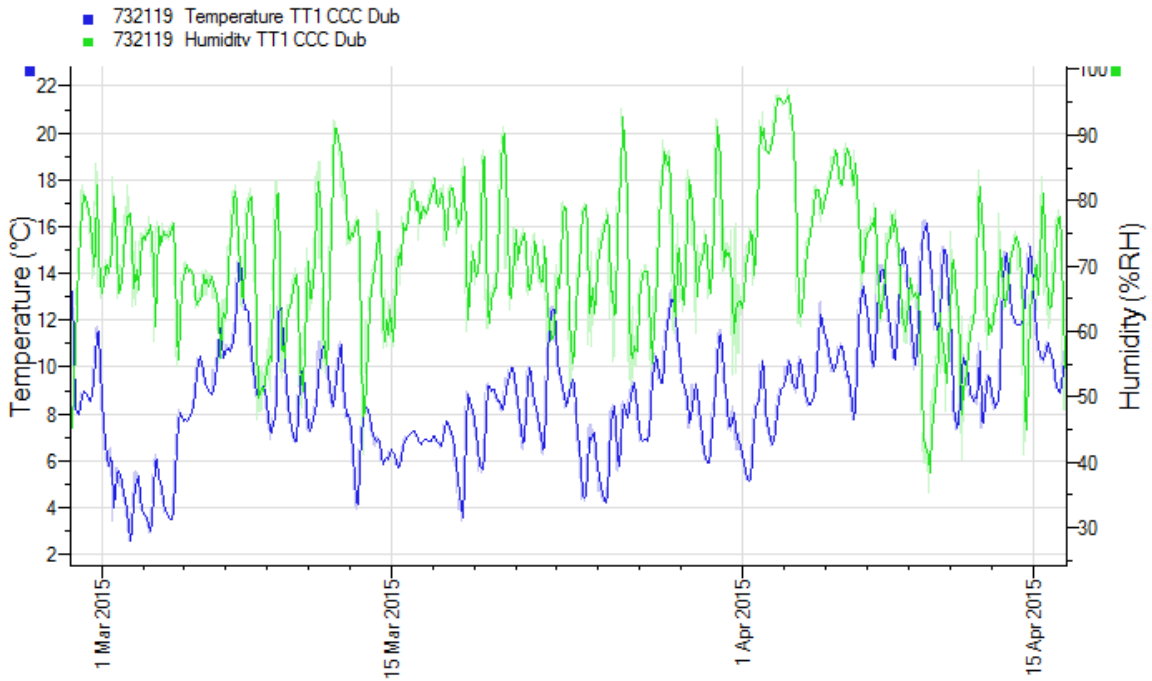

Appendix 16 – St. Mary’s Roman Catholic Cathedral



Kilkenny

Name: Cathedral Church of the Assumption of the Blessed Virgin Mary.

Location: Kilkenny City, Republic of Ireland.

Tradition: Roman Catholic.

Outline history: The cathedral Church of The Assumption of the Blessed Virgin Mary is commonly called St. Mary's cathedral. The cathedral was consecrated on 4 October 1857 and is Gothic in design. It occupies the highest point in the city of Kilkenny and has an unusually high tower which stands at a height of 56.8 meters and which can be seen for many miles around the city. The design of the cathedral is similar to that of Gloucester cathedral in England although the interior bears a quite close resemblance to St. Fin Barre's cathedral in Cork. The cathedral was built during the famine in Ireland and unlike some other cathedrals which were being built at the time and where work was suspended during the famine, work on St. Mary's continued and provided much needed work during that time. The building is built of local Kilkenny marble, which gives the building a dark appearance. There is a statue of St. Patrick outside the West door of the cathedral and there is a school beside the cathedral. The cathedral has a large and well used cafeteria beneath the building. St. Mary's is one of two cathedrals in Kilkenny the other being the Church of Ireland, St. Canice's. This is a cruciform cathedral with nave and side aisles. The walls are stone and not plastered internally. The ceiling is wooden and there appears to be no insulation between the ceiling and roof. The west door is protected by a porch/lobby. The pews are wooden as are some of the other internal fittings. The floor is stone and it is most unlikely that there is any insulation beneath it.

Appendix 16.1 – Floor plan with loggers and TinyTag location

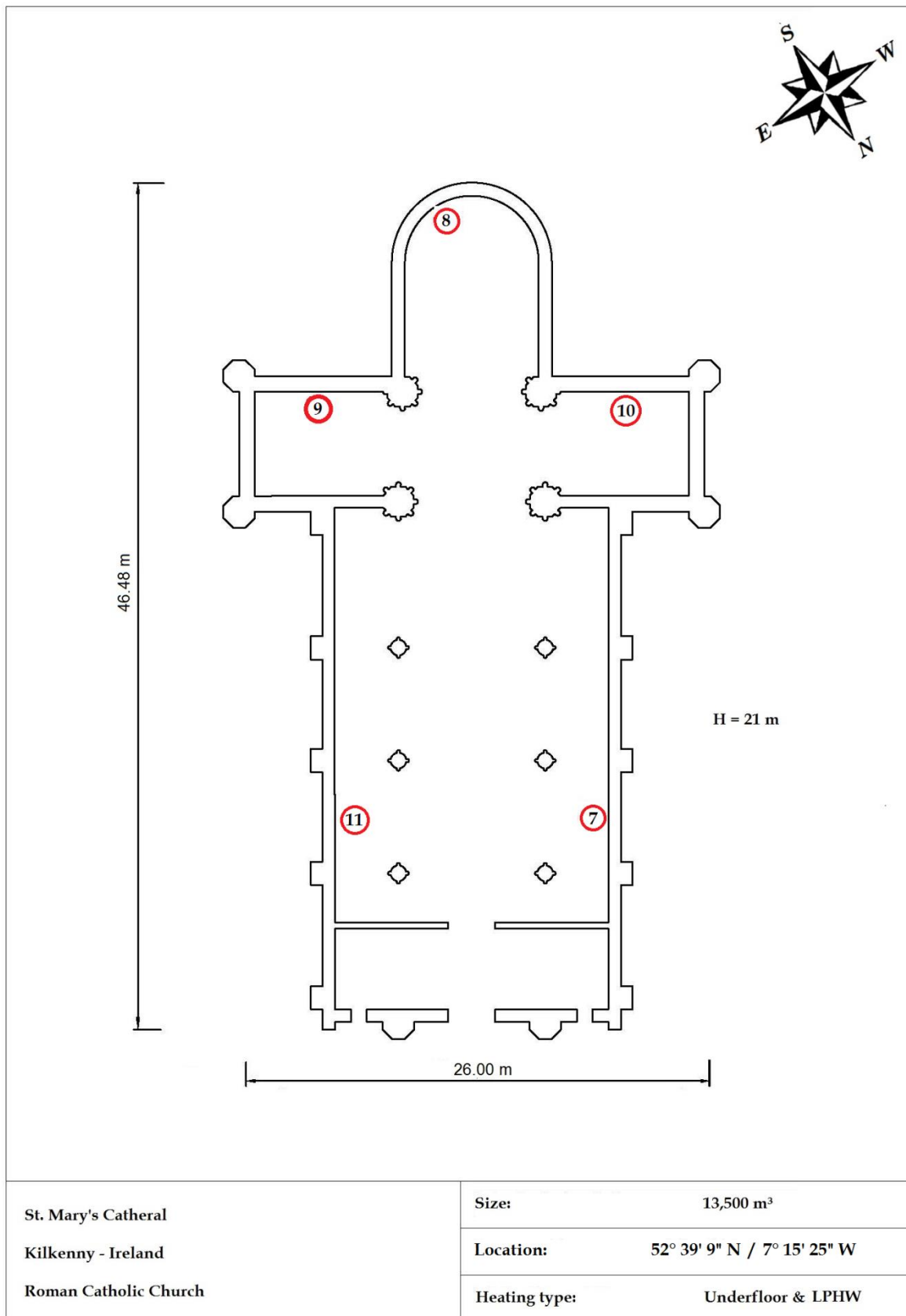

Appendix16.2 – Loggers' graphs

Logger 7 St. Mary's Kilkenny

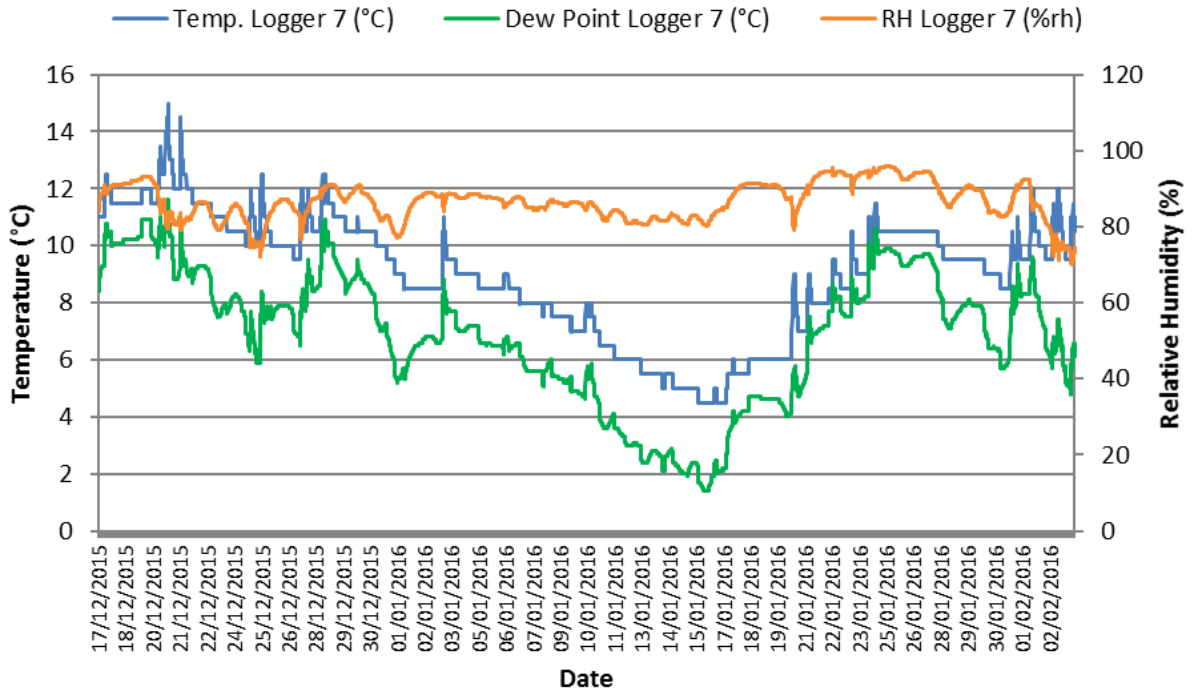

Logger 8 St. Mary's Kilkenny

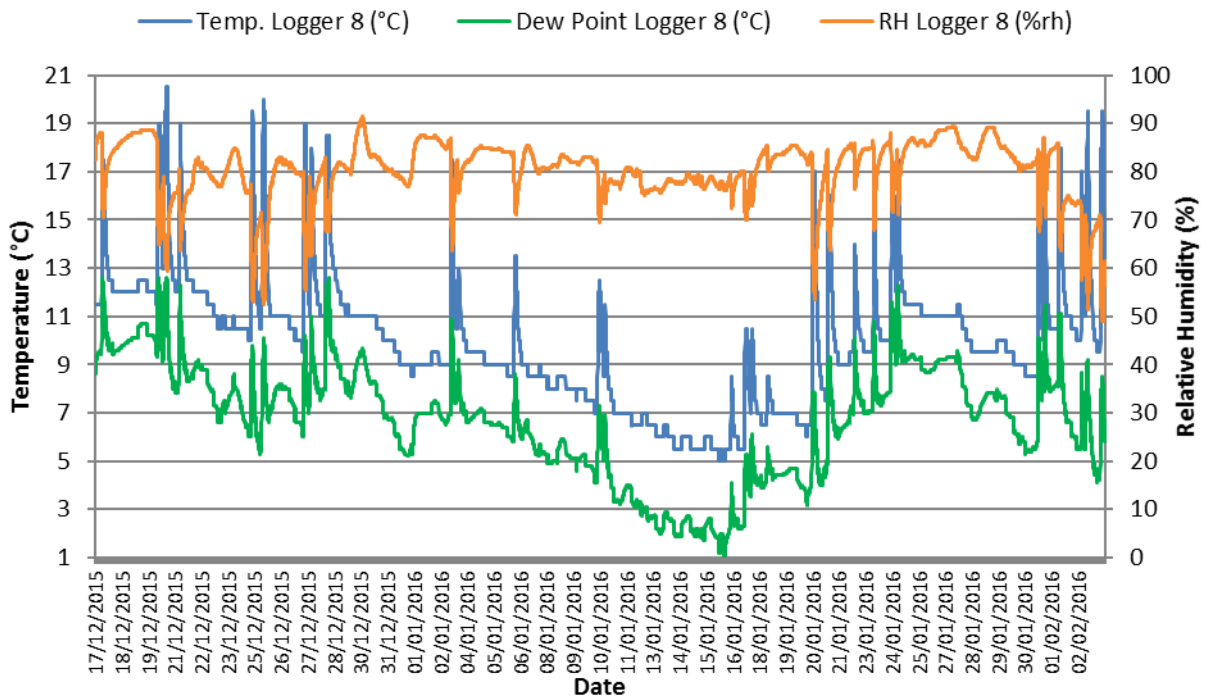

Logger 9 St. Mary's Kilkenny

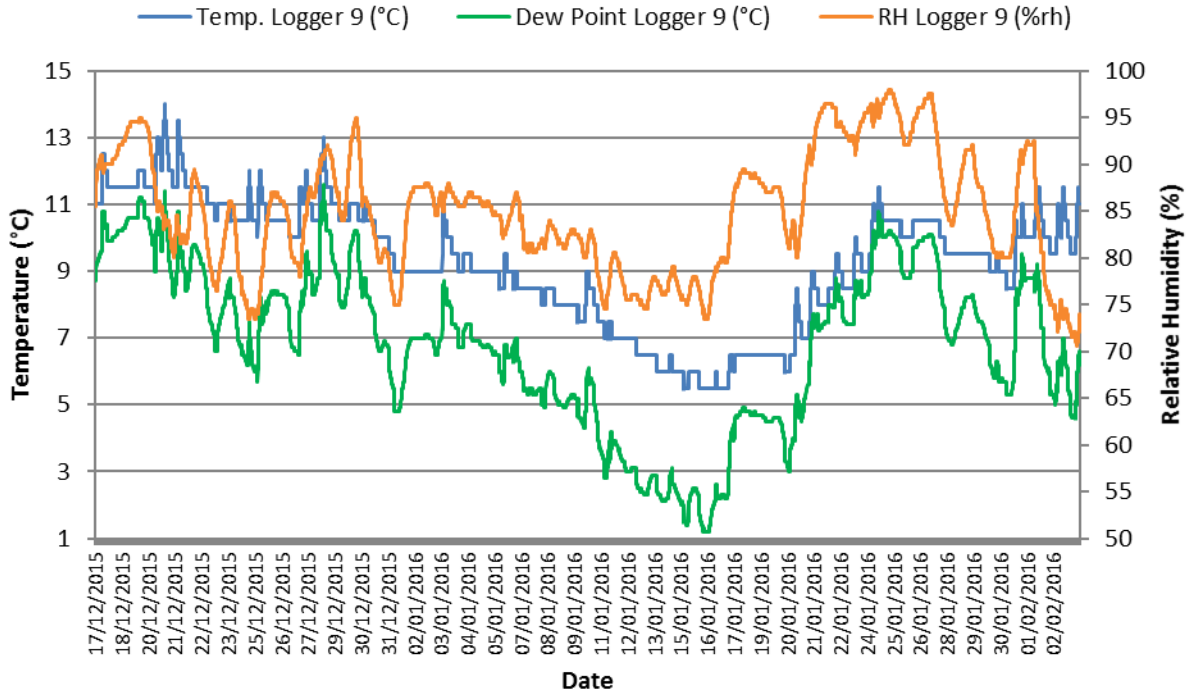

Logger 10 St. Mary's Kilkenny

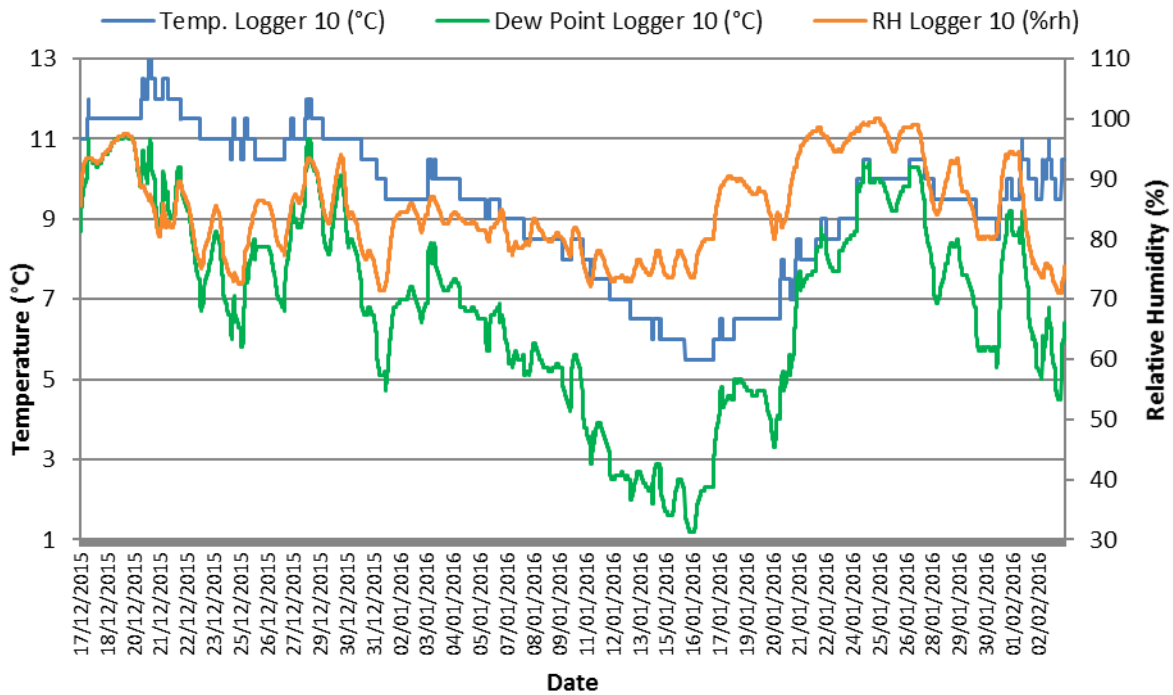

Logger 11 St. Mary's Kilkenny

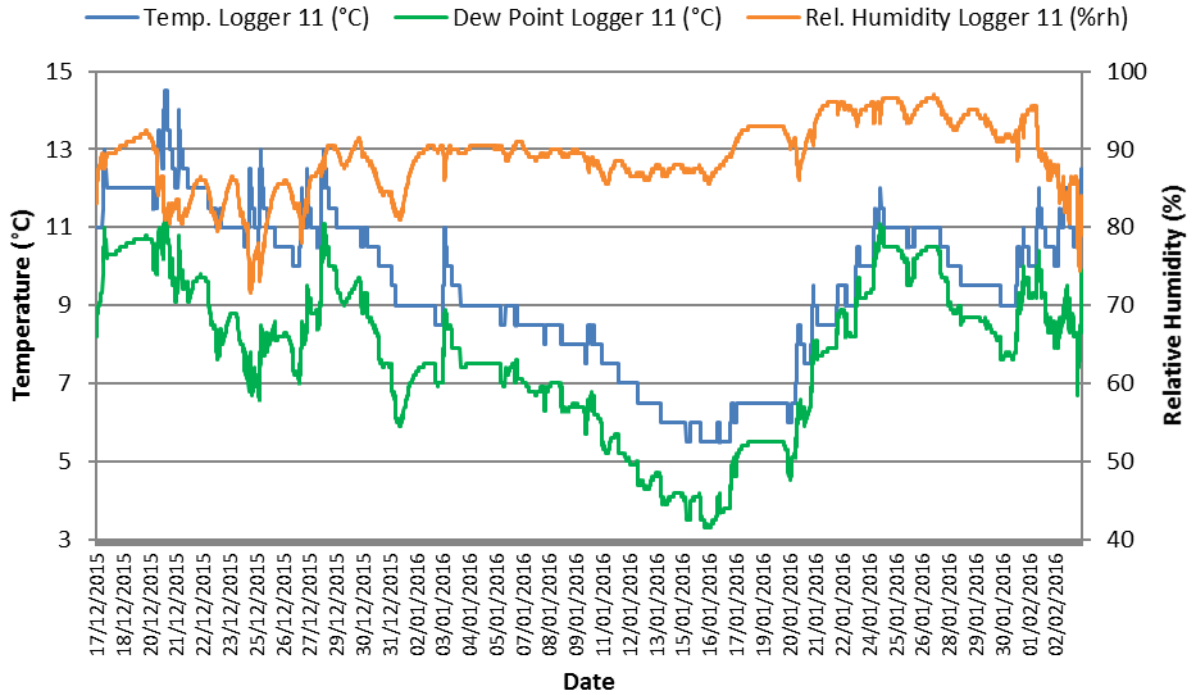

Appendix 16.3 – Tinytag graph (outside T and RH)

TT4 St. Marys Kilkenny

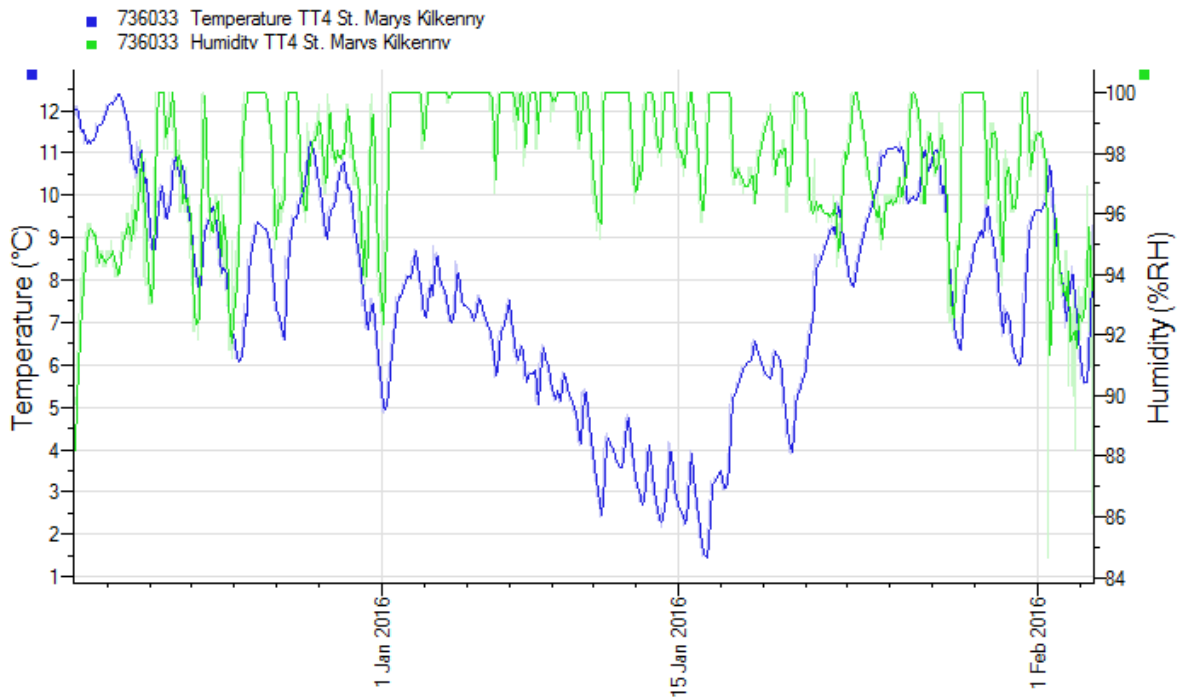

Appendix 17 – Cathedral Church of St. Flannan, Church of Ireland



Killaloe

Name: The cathedral Church of St. Flannan.

Location: Killaloe City, Republic of Ireland.

Tradition: Church of Ireland.

Outline history: A church was built in Killaloe, on the banks of the River Shannon, between 1195 and 1225 but about St. Flannan, to whom the cathedral is dedicated, little is known. What is known is that he was not the same St. Flannan who worked in the Hebrides for many years and after whom the Flannan Islands are named. Brian Boru, the famous High King of Ireland (1002-1014) was born nearby and he made Killaloe the capital of his kingdom in Claire.

Little is known of the history of the present cathedral until the 1700s but it seems to have suffered at various times from power struggles amongst various Irish chiefs. Various improvements were carried out to the building during the 1700s including raising height of the tower so that a peal of bells could be installed.

The cathedral today contains some very fine stained glass windows, as well as a number of ancient Irish stone crosses and memorials, some of which were brought from other churches to Killaloe for safe keeping. The cathedral is open every day to visitors although half of the nave is separated by a wooden and glass screen as dwindling congregations mean that the whole nave is no longer required for services. Just outside the cathedral is the well preserved remains of the 12th century St. Flannan's Oratory. This cathedral is cruciform in shape. The walls are stone with plaster and paint on the inside. The floor is tiles and stone. There is no evidence of insulation in any part of the building. Only part of the nave is used for services and the nave is divided by a wooden and glass screen. The building contains a number of stone artifacts, some of which have been moved form other churches.

Appendix 17.1 – Floor plan with loggers and TinyTag location

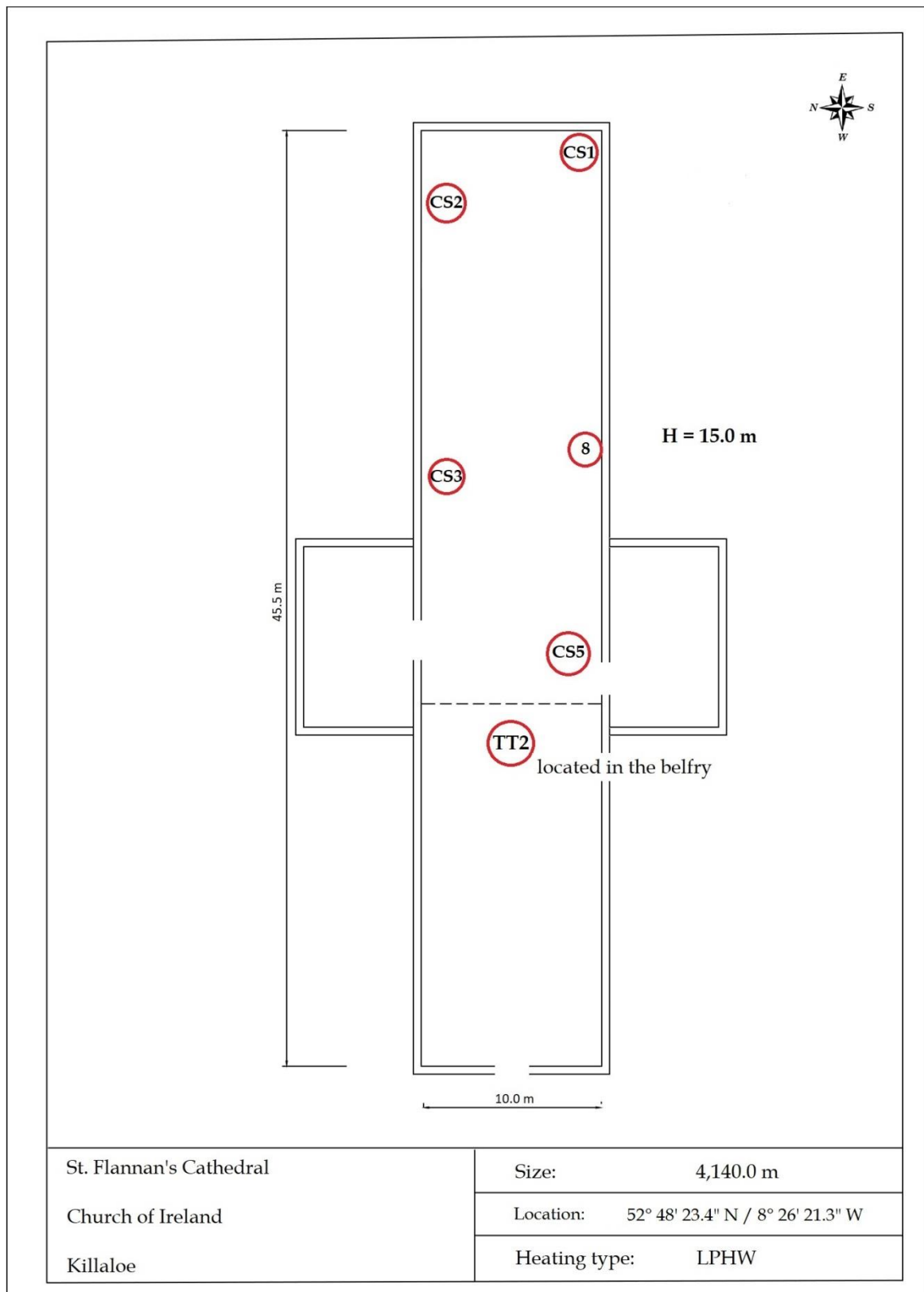

Appendix 17.2 – Loggers' graphs

Logger CS1 St. Flannan's Killaloe

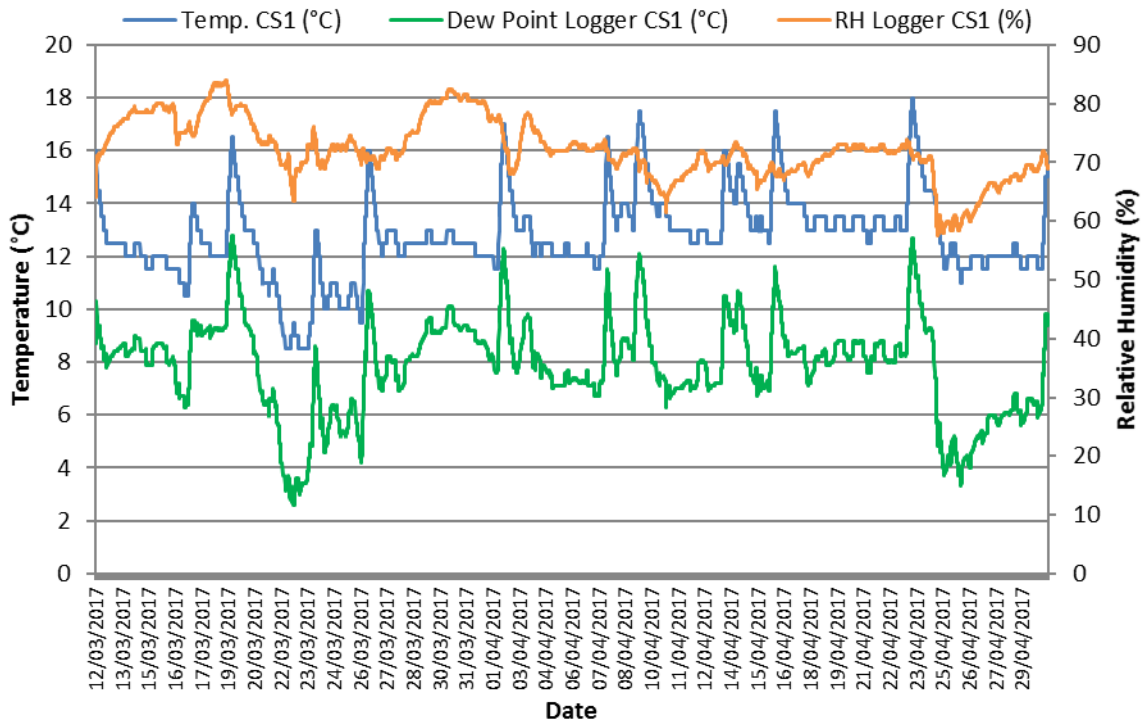

Logger CS2 St. Flannan's Killaloe

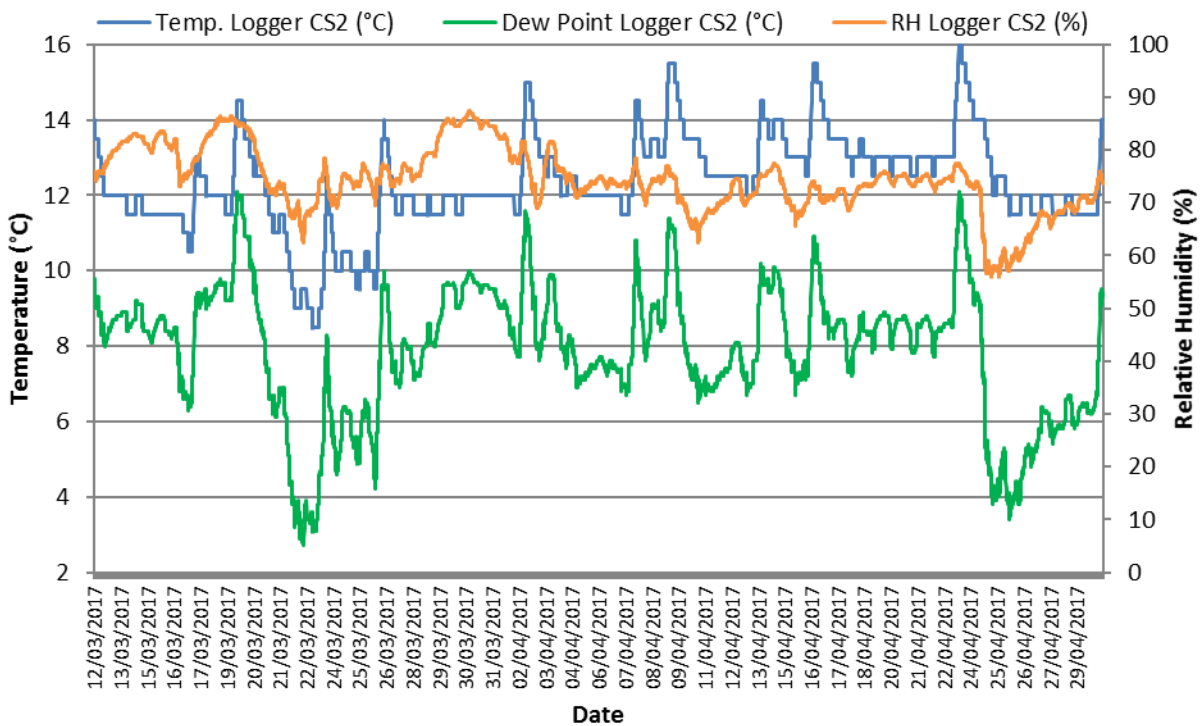

Logger CS3 St. Flannan's Killaloe

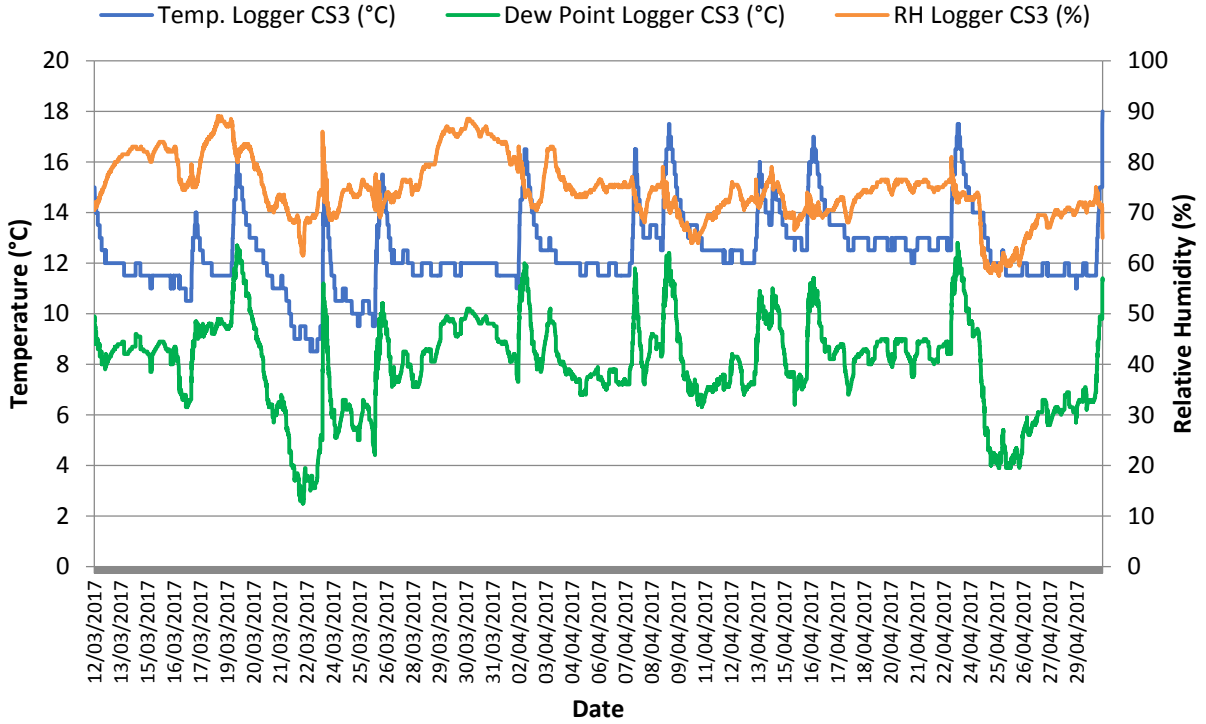

Logger CS5 St. Flannan's Killaloe

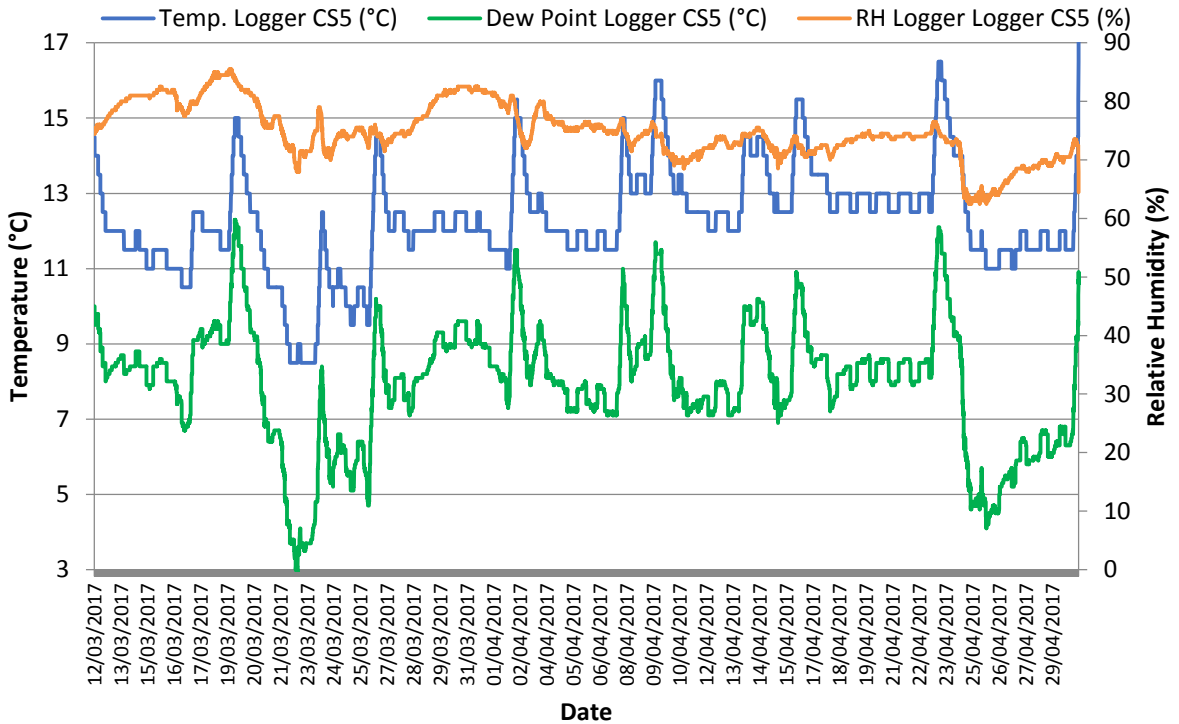

Logger 8 St. Flannan's Killaloe

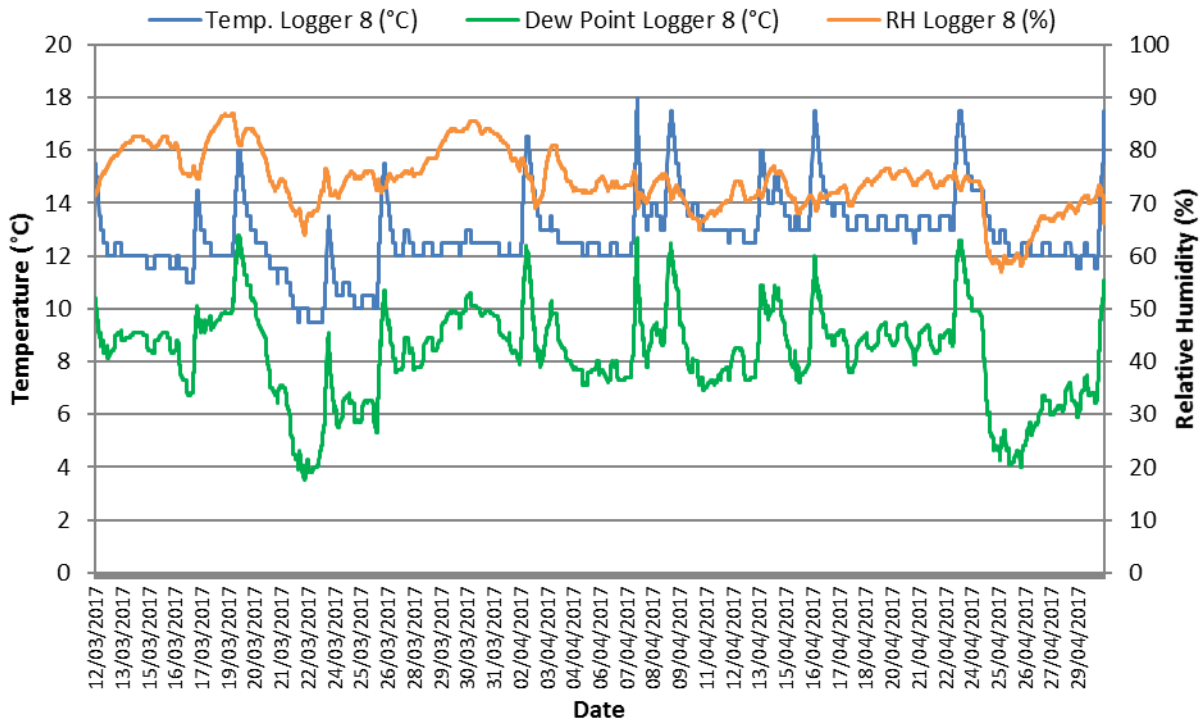

Appendix 17.3 – Tinytag graph (outside T and RH)

TT2Killaloe

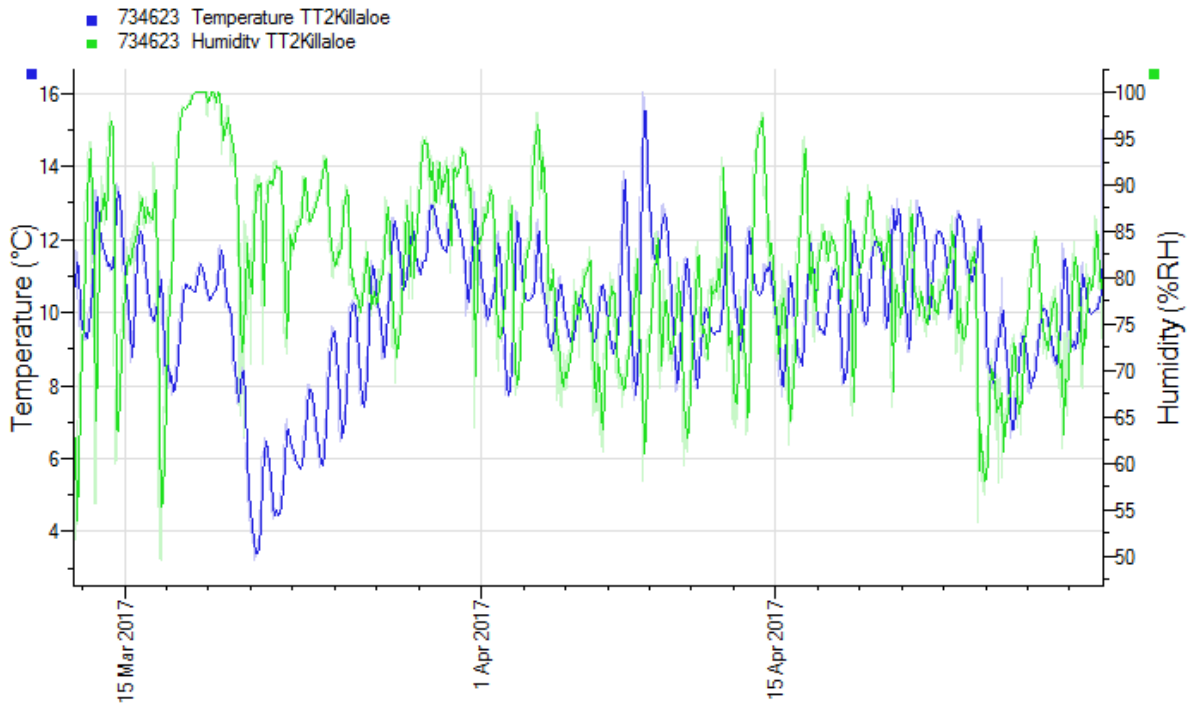

Appendix 18 – St. Eunan's Church of Ireland Cathedral



Raphoe

13th-century choir, looking east towards the altar. By: Andreas F. Borchert (License: CC BY-SA 3.0 de)

Name: The

Cathedral Church of St. Eunan.

Location: Raphoe, Republic of Ireland.

Tradition: Church of Ireland.

Outline history: Details about this cathedral are somewhat scarce. There was supposed to have been a monastery on the site founded by St. Columba in the 6th century and the history of Raphoe refers to the early ring forts and huts which were the earliest type of Christian monasteries in Ireland. When the present cathedral was built is not known but there are elements of a 12th century building included in the present cathedral. The cathedral was virtually rebuilt in around 1605 by Rt. Rev. Dr. George Montgomery who was chaplain to King James 1 of England and much of the present building dates from the 1700s. Inside the cathedral is an old consistory court which is now used for baptisms. The choir is longer than the nave which suggests that the clergy often outnumbered the congregation as they performed their elaborate ceremonies. The former bishops palace, which is much larger than the cathedral, is suited a short distance from the cathedral. The palace was occupied until 1834 and then abandoned. The cathedral has no side aisles or pillars. The floor is stone and walls are stone with plaster. There is some exposed stone work internally. The ceiling is wooden but there are no details concerning the void between the ceiling and roof. There is a considerably quantity of wood with the building and there is a wooden consistory court inside the west door although this area is now used for baptisms.

Appendix 18.1 – Floor plan with loggers and TinyTag location

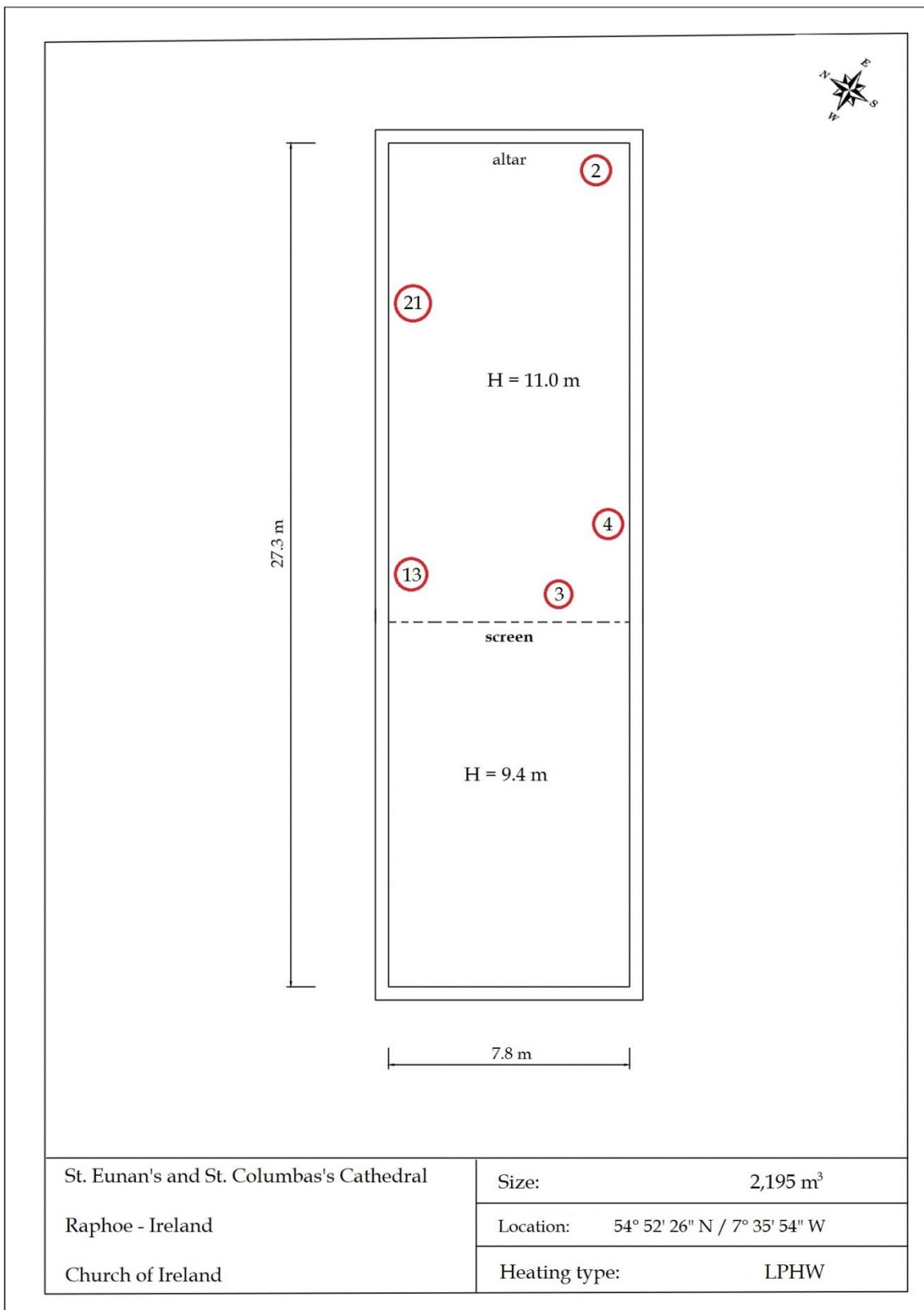

Appendix 18.2 – Loggers' graphs

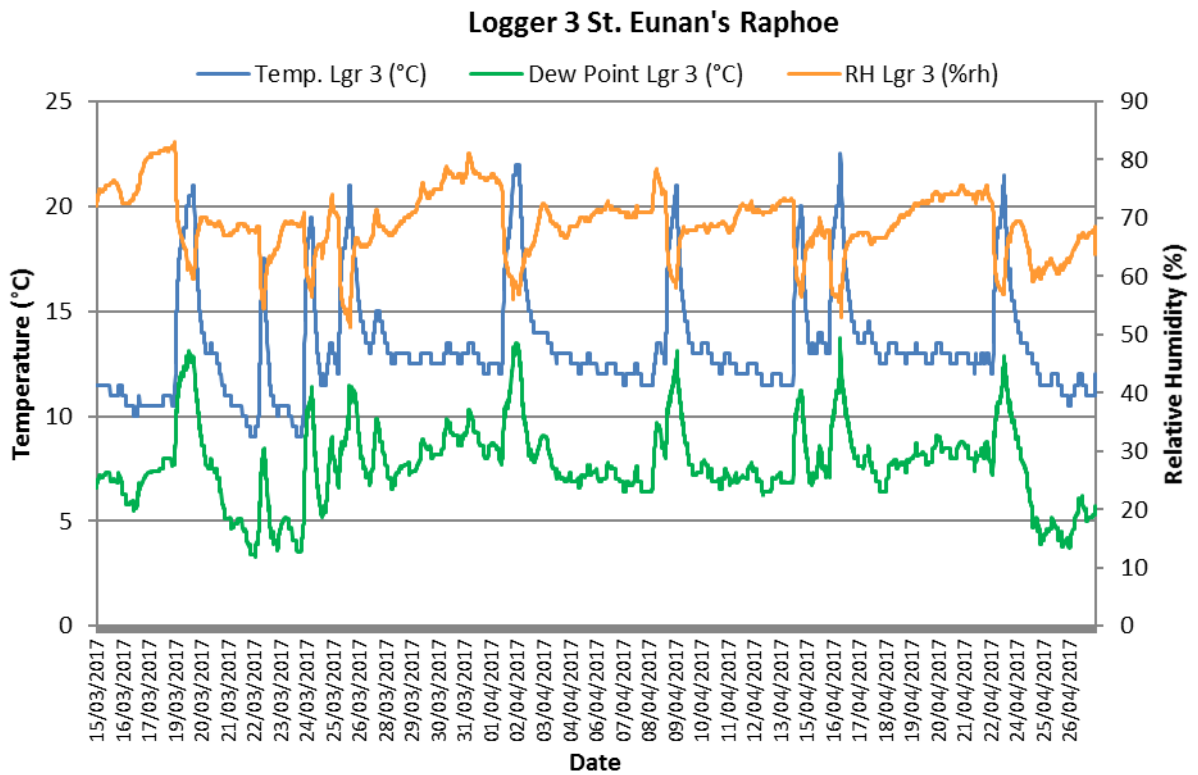
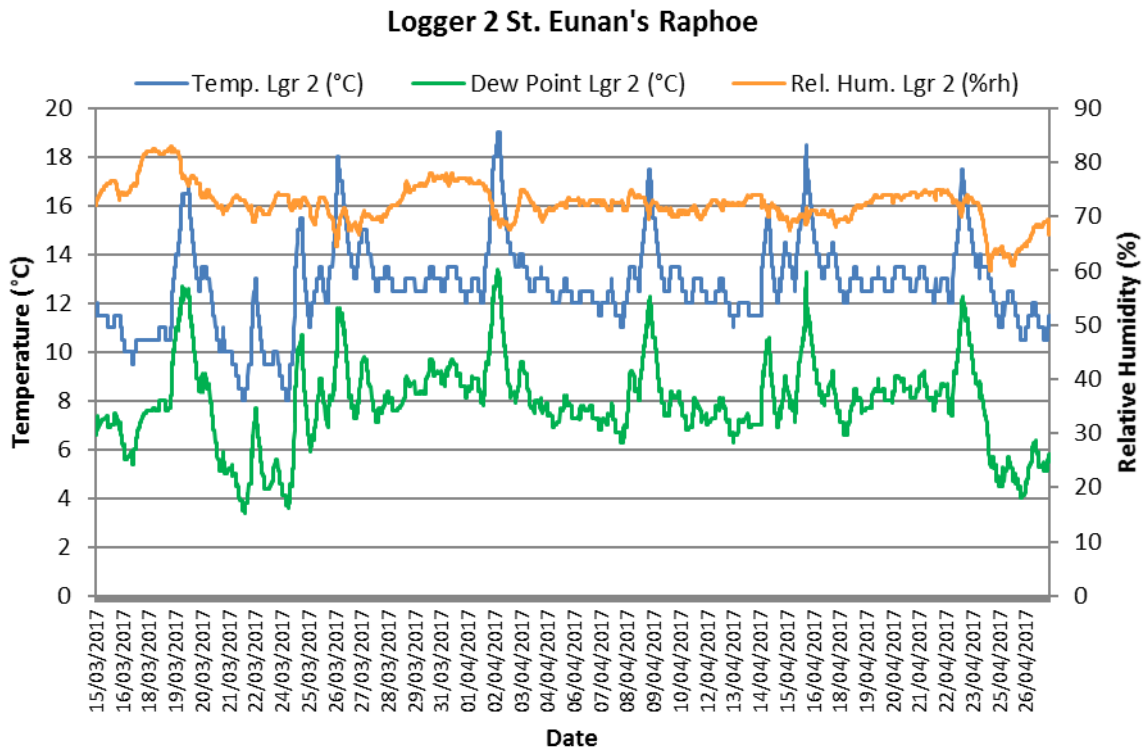

Logger 4 St. Eunan's Raphoe

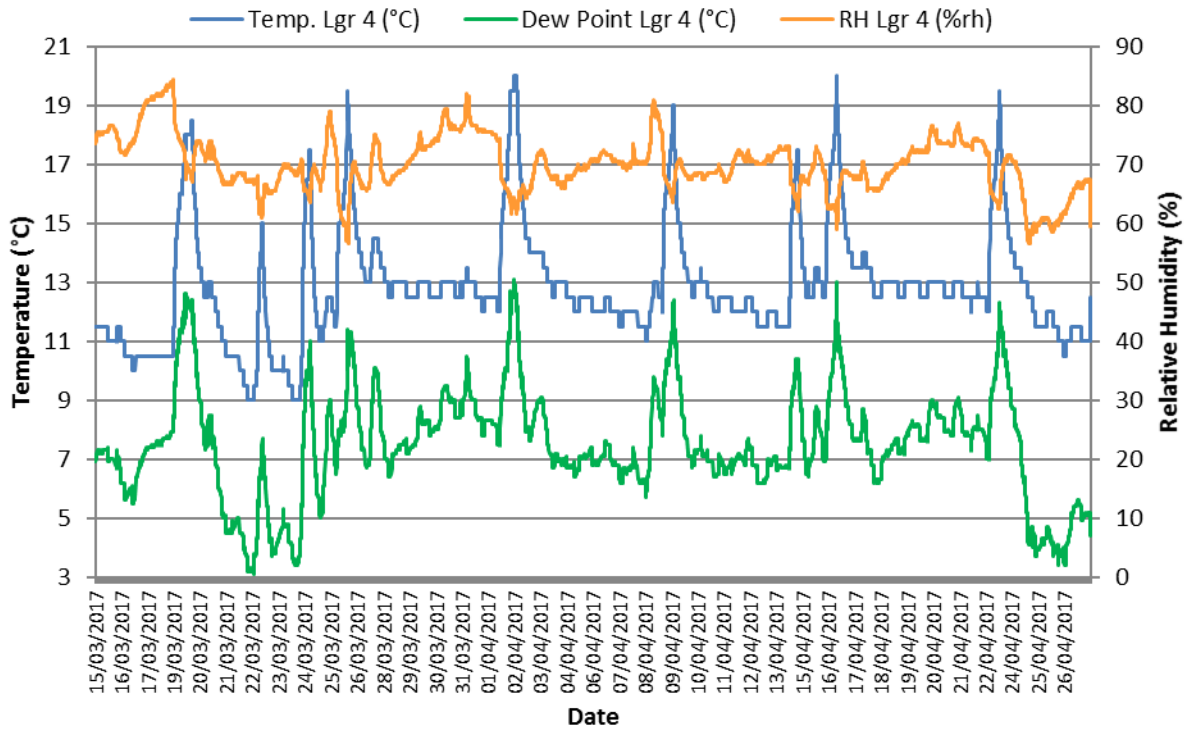

Logger 13 St. Eunan's Raphoe

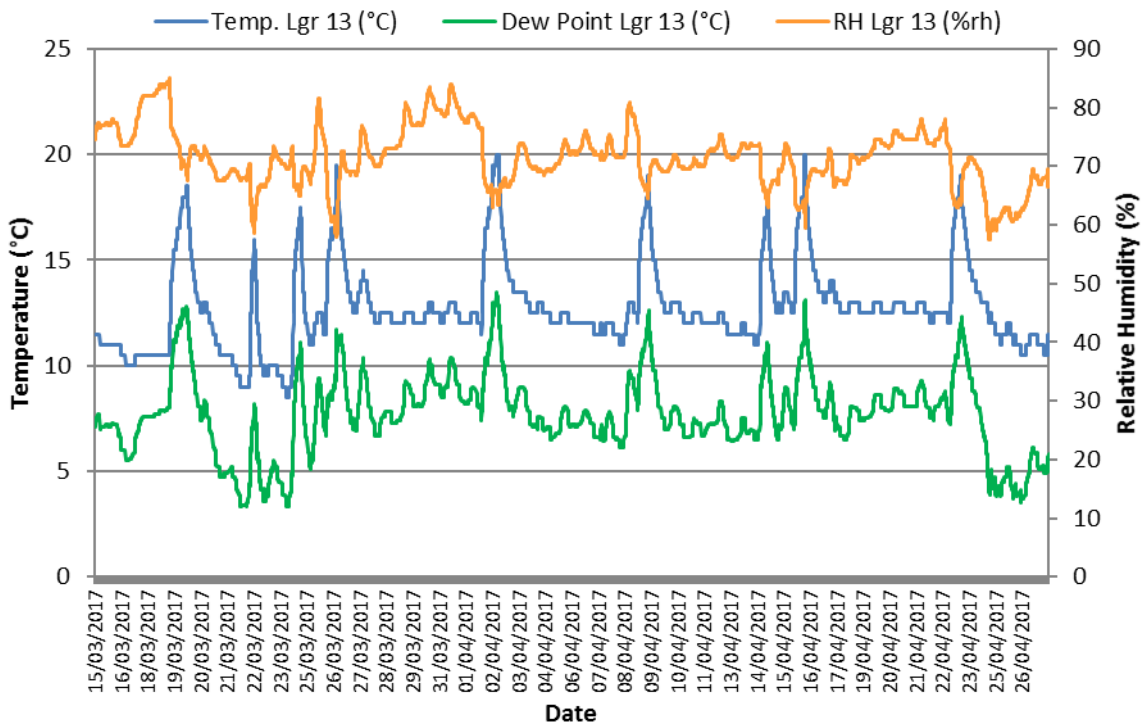

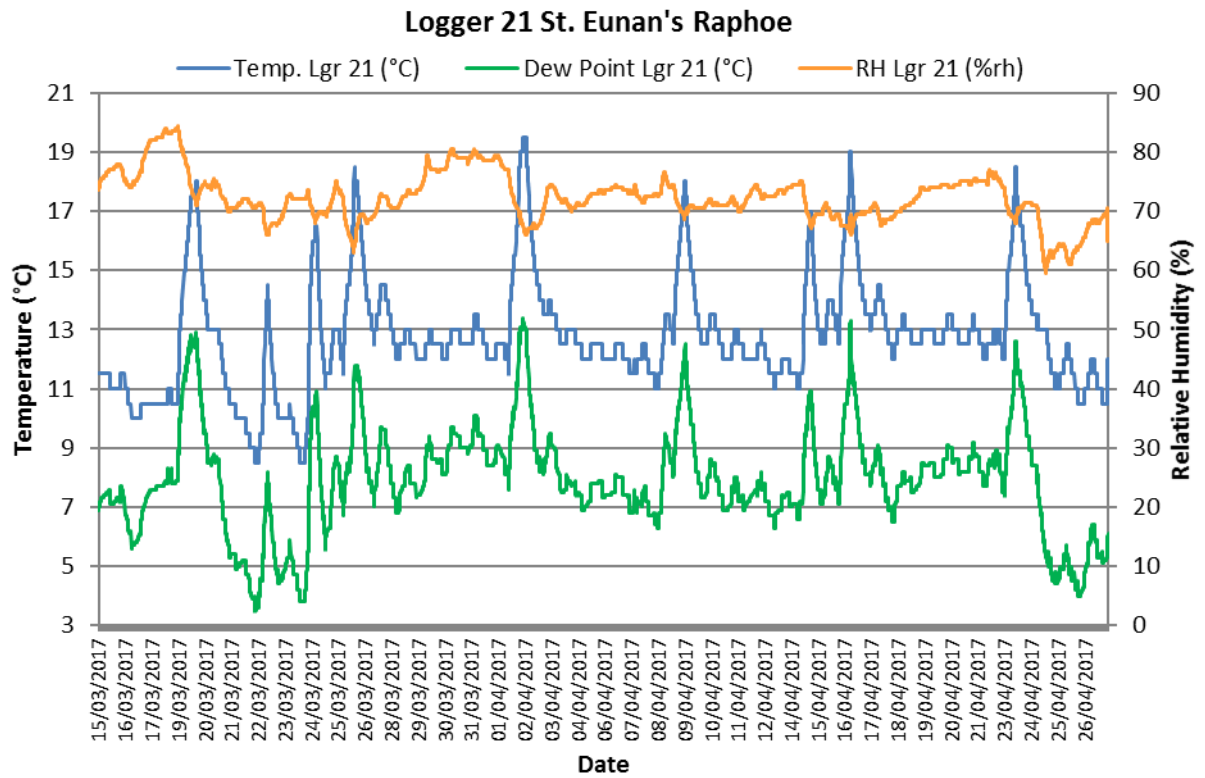

Appendix 18.3 – Tinytag graph (outside T and RH)

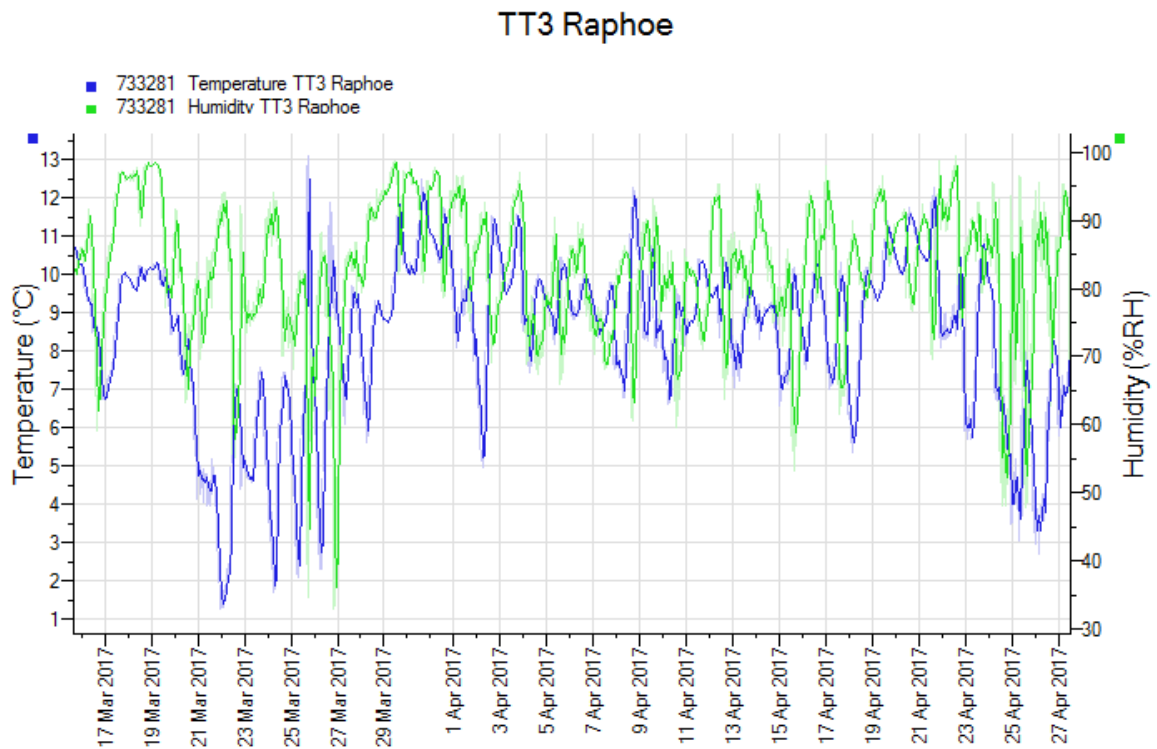

Appendix 19 – St. Lasarian’s Church of Ireland Cathedral



Authors: Jim Dempsey and Deb Snelson.. (Source: Megalithic Ireland Blog, 2011)

Old Leighlin

Name: The Cathedral Church of St. Laserian.

Location: Old Leighlin , Republic of Ireland.

Tradition: Church of Ireland.

Outline history: The community which resided in the area surrounding the current cathedral was formed by St. Gobhan in circa 600 and his successor St. Laserian built up a community of some 1,500 people making it a major ecclesiastical site. In a synod in Leighlin in 630 the Irish church adopted the Roman calendar and the method for calculating the date of Easter. The original church on the site was destroyed by fire and the present cathedral built circa 1170 with most of the present fabric dating from the 12th and 13th centuries. The building is strange because it is not symmetrical, there are no windows in the nave and a number of doors have, for unknown reasons, been blocked up. The cathedral has had a somewhat troubled history with a bishop being murdered by his archdeacon who was in turn hanged in the building and in the last century a dean was murdered for sectarian reasons. The cathedral has had a number of benefactors over the centuries but one of the major ones was the Vigors family in the 1800s and who donated the magnificent East window. This window was designed and built by Catherine O'Brien (1881-1963) who was with the Tower of Glass stained glass studio and which is referred to in the piece about Loughrea cathedral. This plain and ancient cathedral has no side aisles. The nave has stone walls with no internal plasterwork. The ceiling of the cathedral is wooden but this was a fairly recent addition and there are no details available concerning the roof. The floor of the nave is stone and there are many wooden fittings within the building.

Appendix 19.1 – Floor plan with loggers and TinyTag location

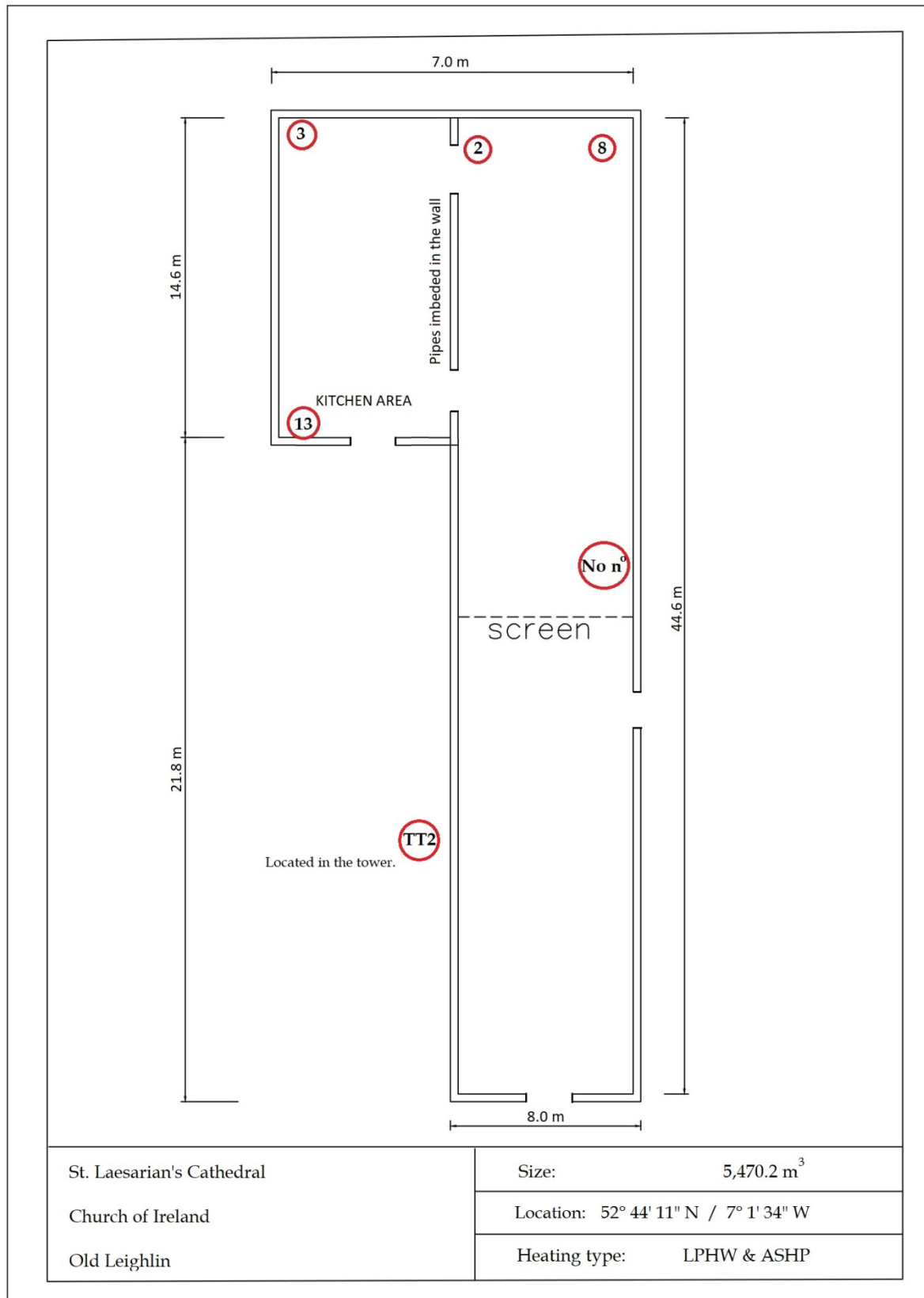

Appendix 23.2 – Loggers' graphs

Logger 2 St. Laesarian's Old Leighlin

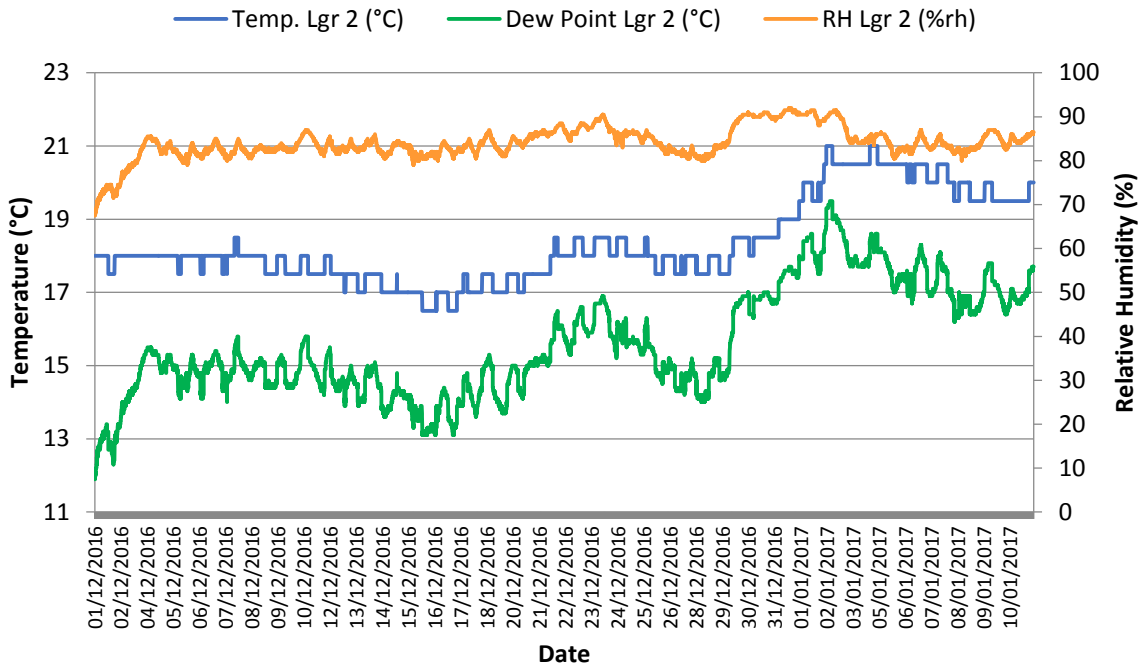

Logger 3 St. Laesarian's Old Leighlin

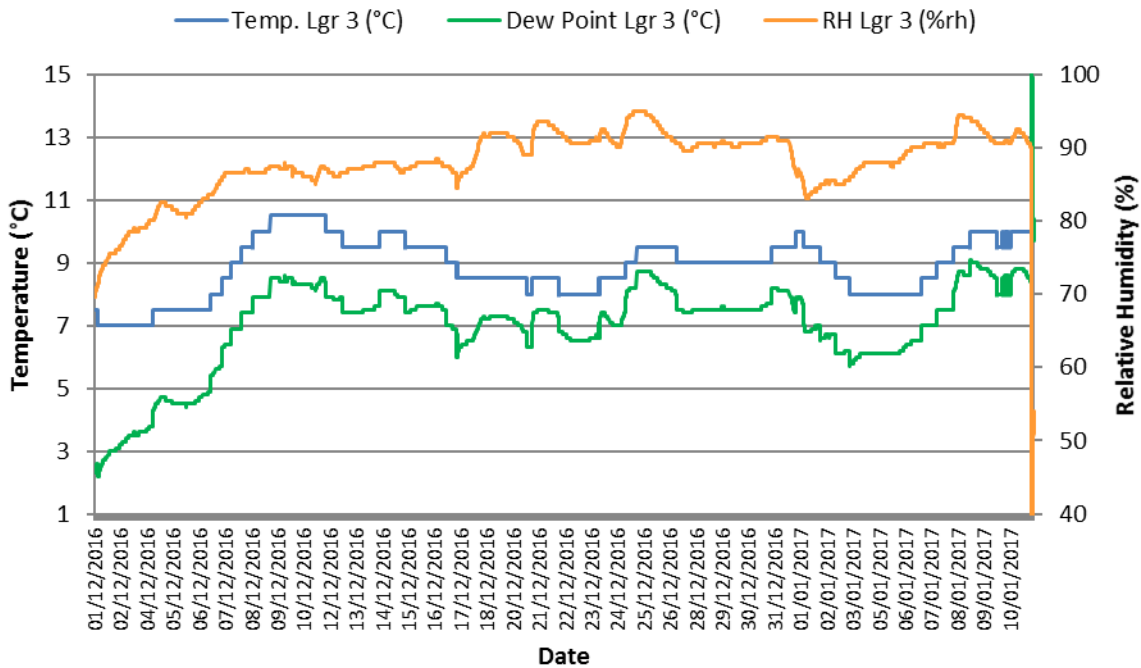

Logger 8 St. Laesarian's Old Leighlin

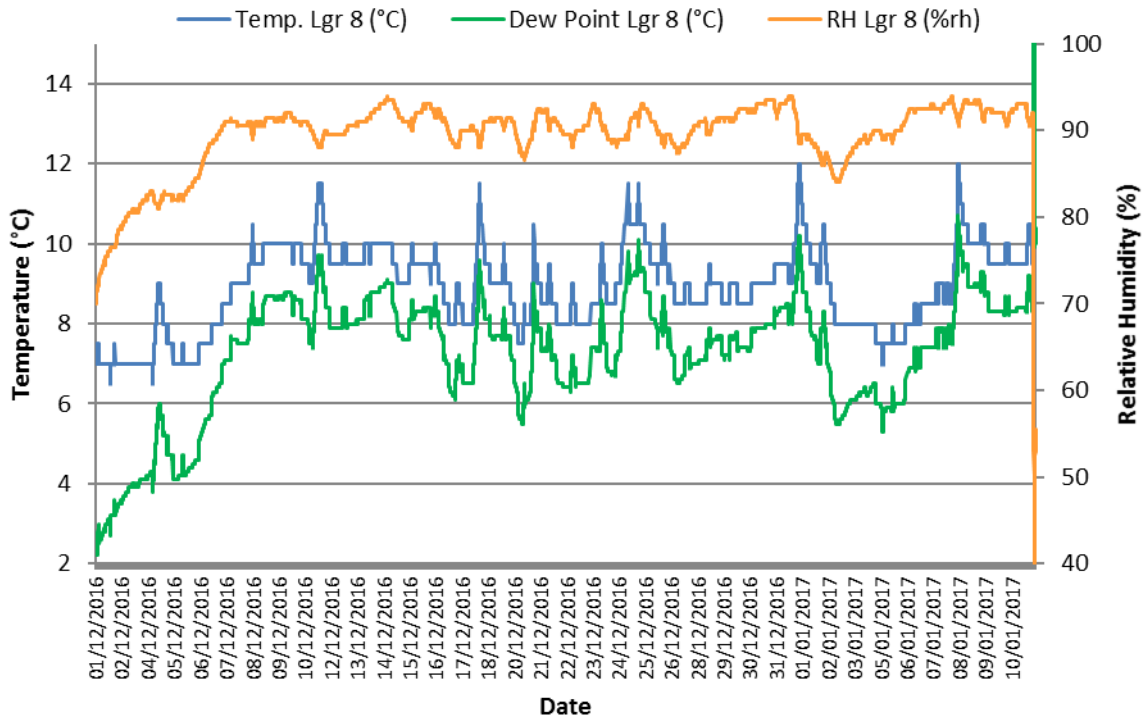

Logger 13 St. Laesarian's Old Leighlin

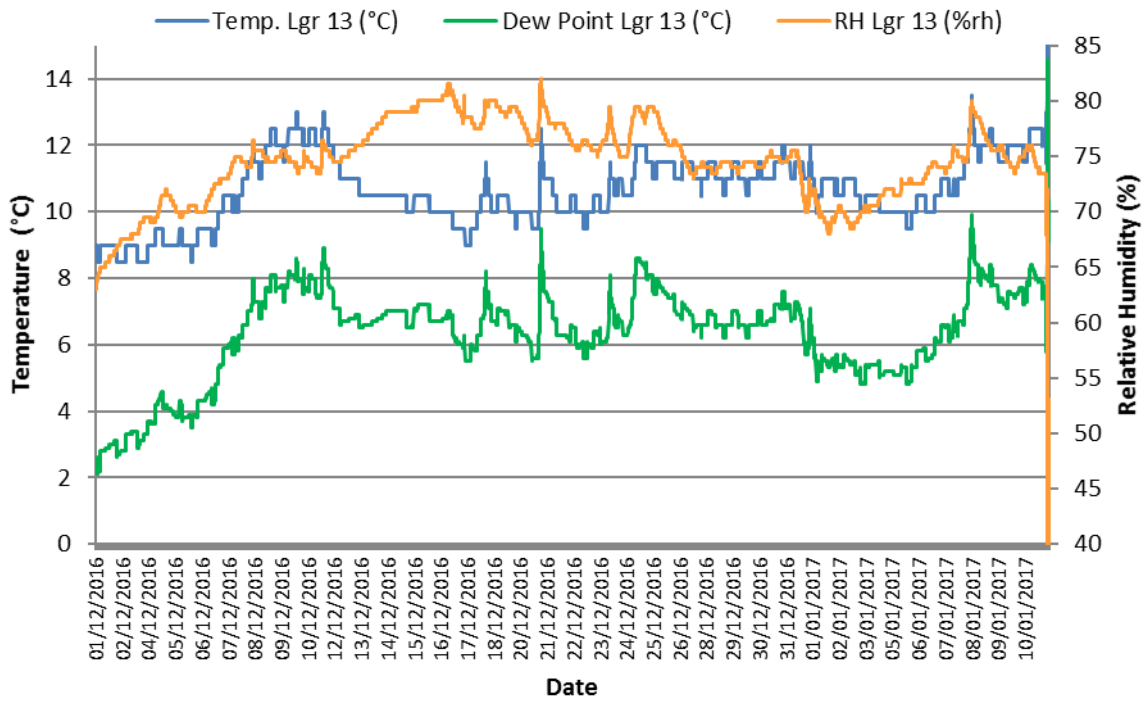

Logger No N° St. Laesarian's Old Leighlin

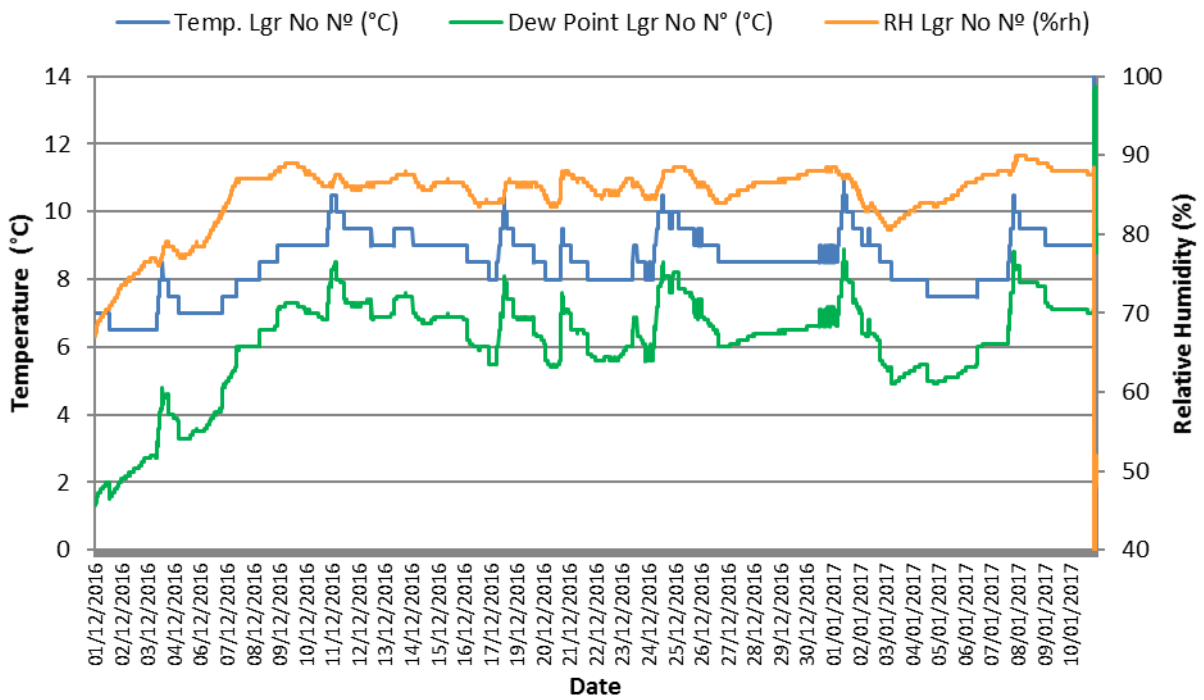

Appendix 19.3 – Tinytag graph (outside T and RH)

TT2 Old Leighlin

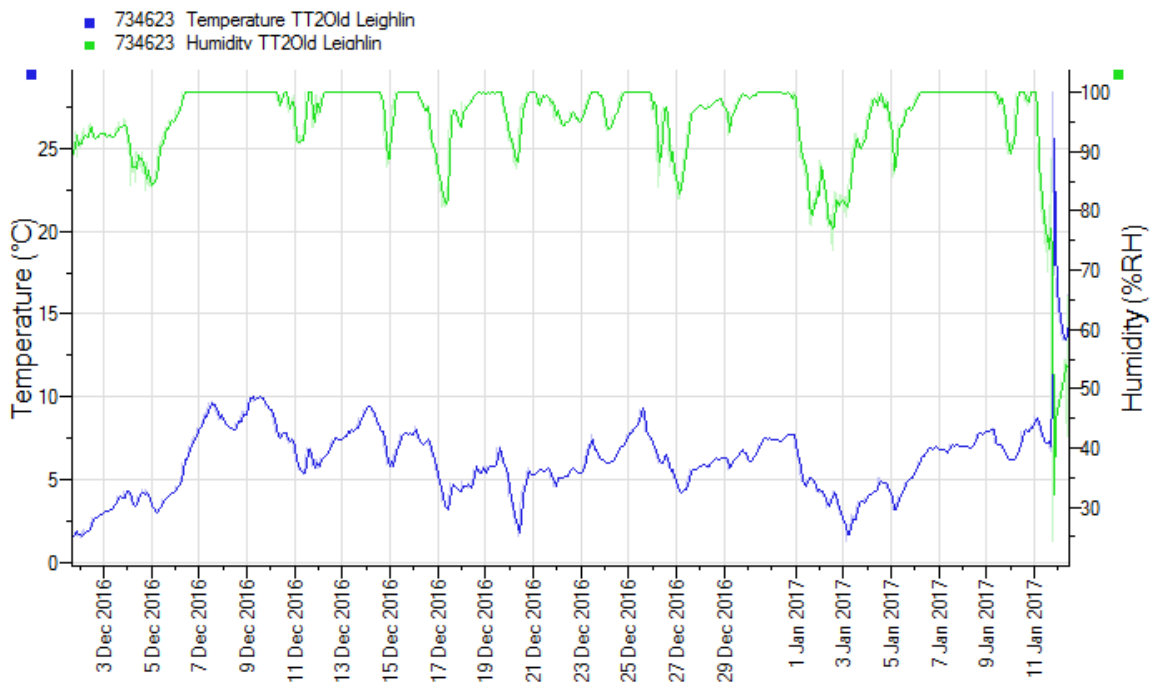

Appendix 20 – St. Carthage's Church of Ireland Cathedral



Lismore

Name: St. Carthage's Cathedral.

Location: Lismore City, Republic of Ireland.

Tradition: Church of Ireland.

Outline history: Lismore cathedral is situated on the banks of the River Blackwater not far from Waterford and is dedicated to St. Carthage who set up a monastery in Lismore in circa 636 having been expelled from a previous monastery which he set up in nearby Rehan. The Lismore monastery became a great center of learning. Unfortunately Lismore's proximity to Waterford meant that it suffered greatly at the hands of the Vikings over the years. There was a medieval cathedral on the site but this was destroyed in circa 1600 by a certain Edmond Fitzgibbon but the first Earl of Cork was determined to rebuild the cathedral and over the next two hundred years or so the cathedral was slowly restored and rebuilt. A library, which is still open to the public today, was opened in 1851. The interior has been greatly altered over the years with many gifts of furnishings being incorporated into the fabric. At present half of the nave is not used and is screened off from the remainder of the cathedral. The cathedral remains open every day to the public for no charge. The nearby Lismore Castle, now the home of the Duke of Devonshire was, until 1585, the home of the Bishop of Lismore until he gave the property to Sir Walter Raleigh. This cruciform cathedral has stone walls which are plastered and painted on the inside. The ceiling is wooden and is also plastered and painted. The floor is tiled with wood beneath the wooden pews. There is a small library situated just off the nave.

Appendix 20.1 – Floor plan with loggers and TinyTag location

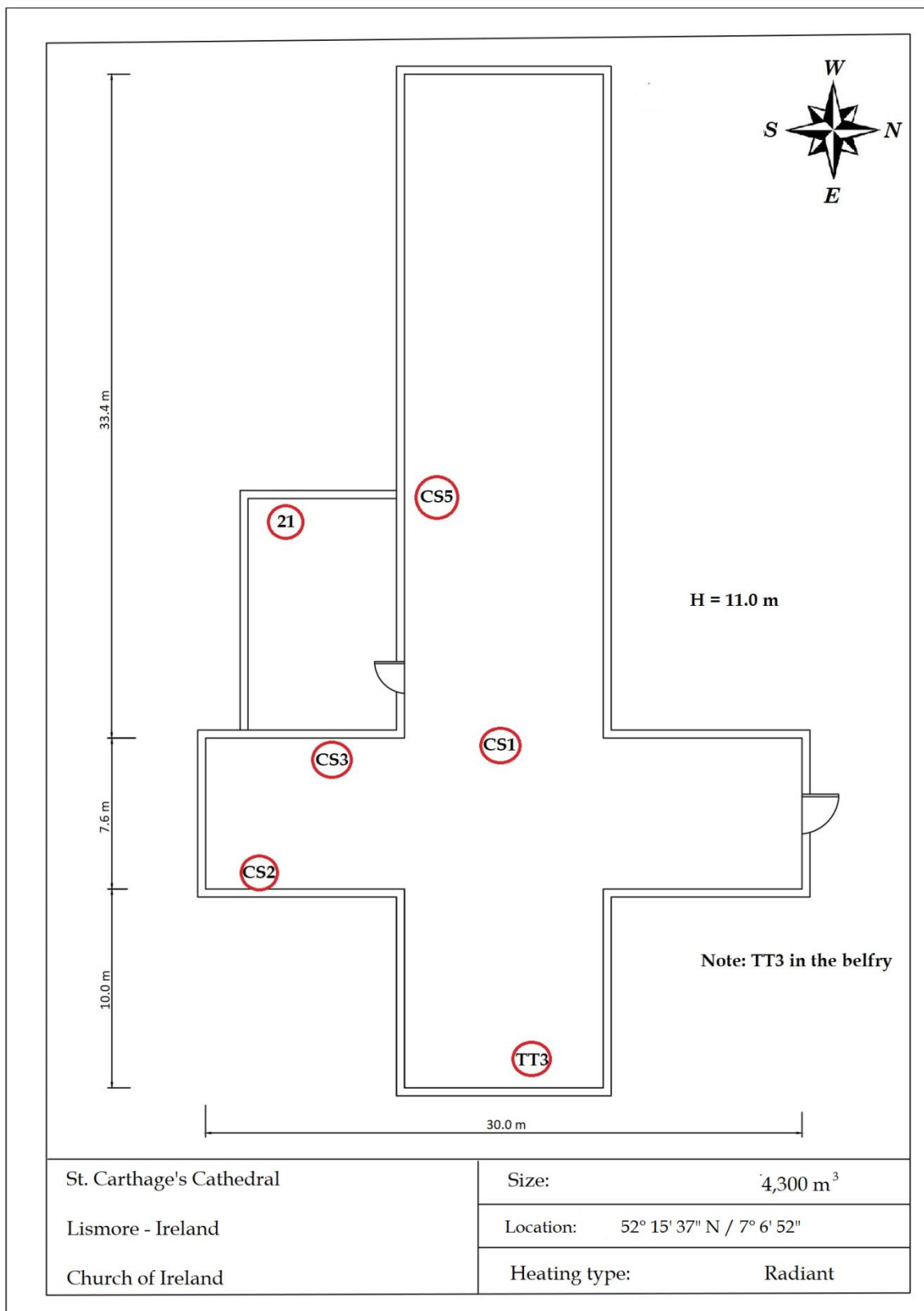

Appendix 20.2 – Loggers' graphs

Logger CS1 St. Carthage's Lismore

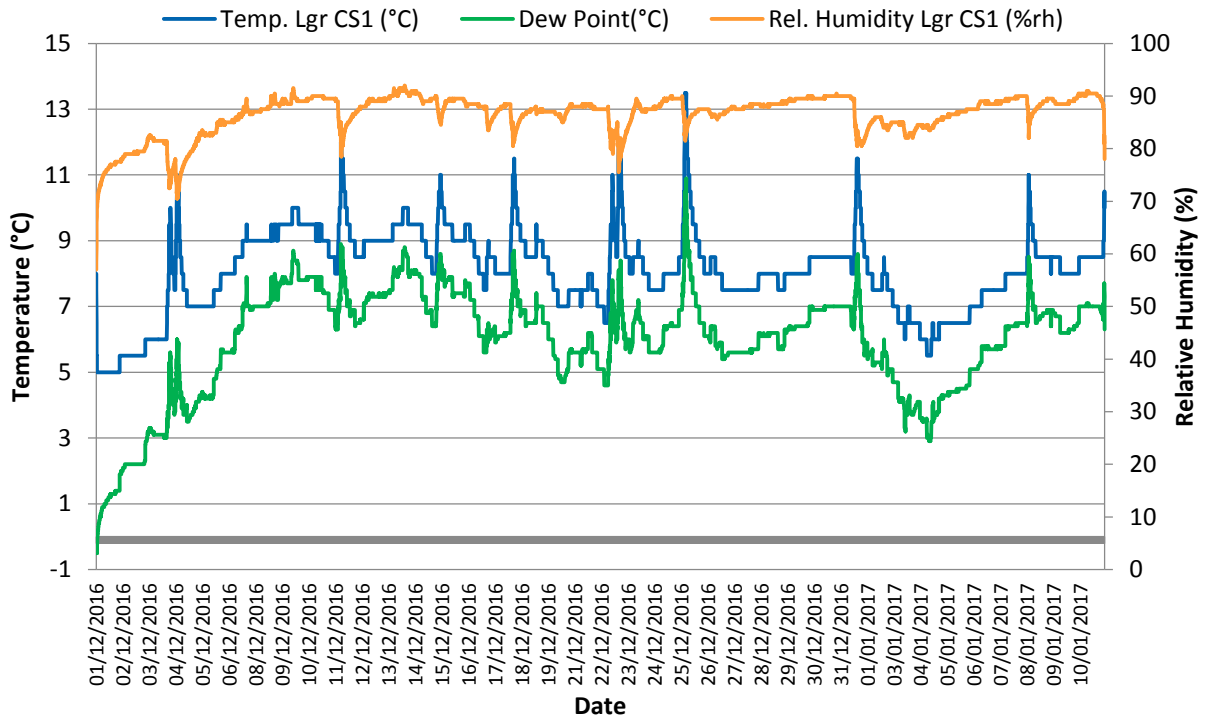

Logger CS2 St. Carthage's Lismore

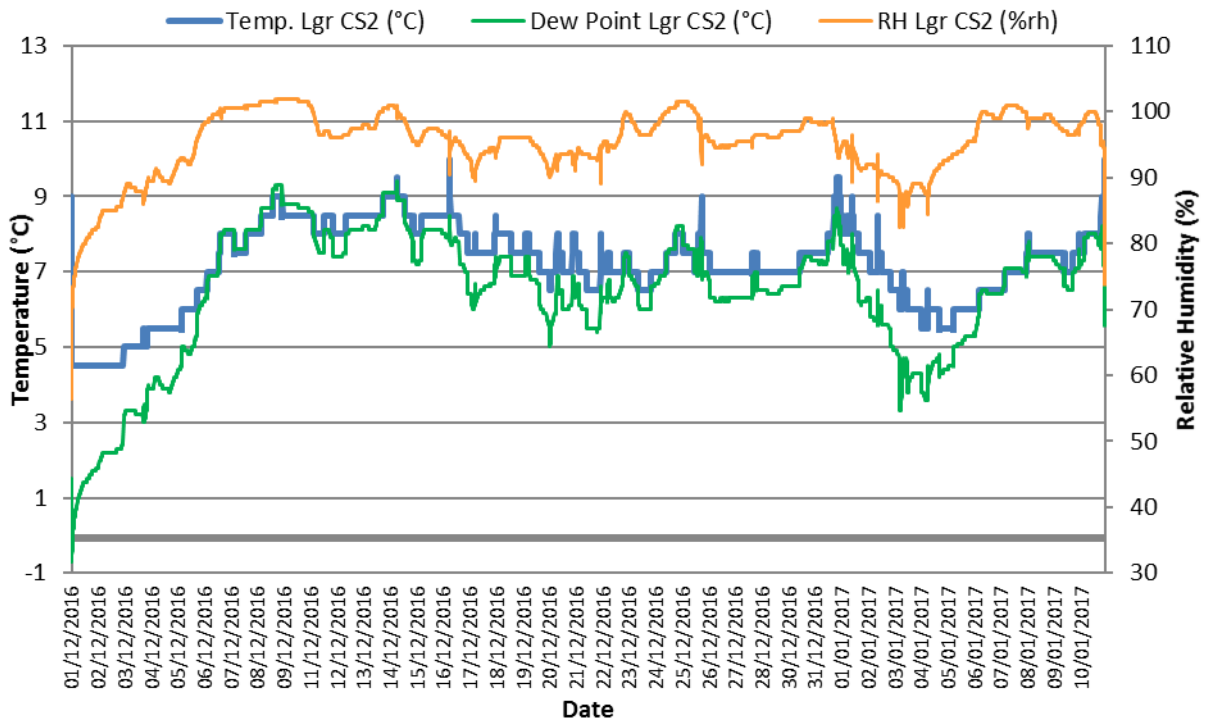

Logger CS3 St. Carthage's Lismore

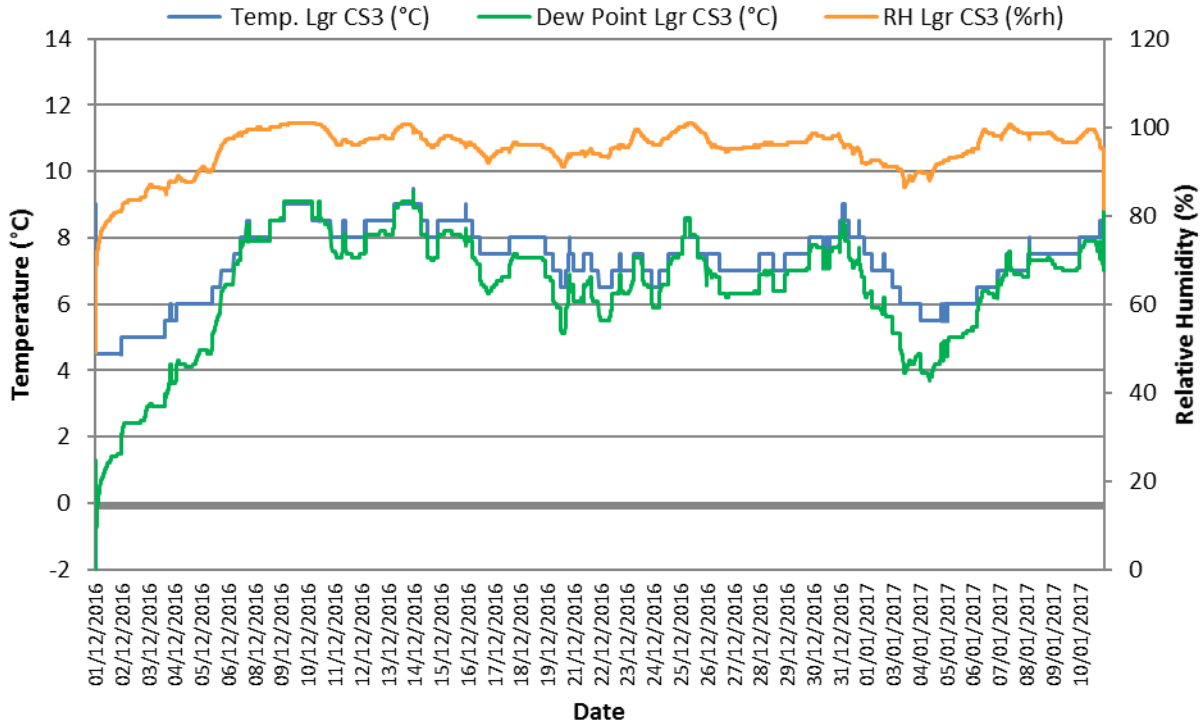

Logger CS5 St. Carthage's Lismore

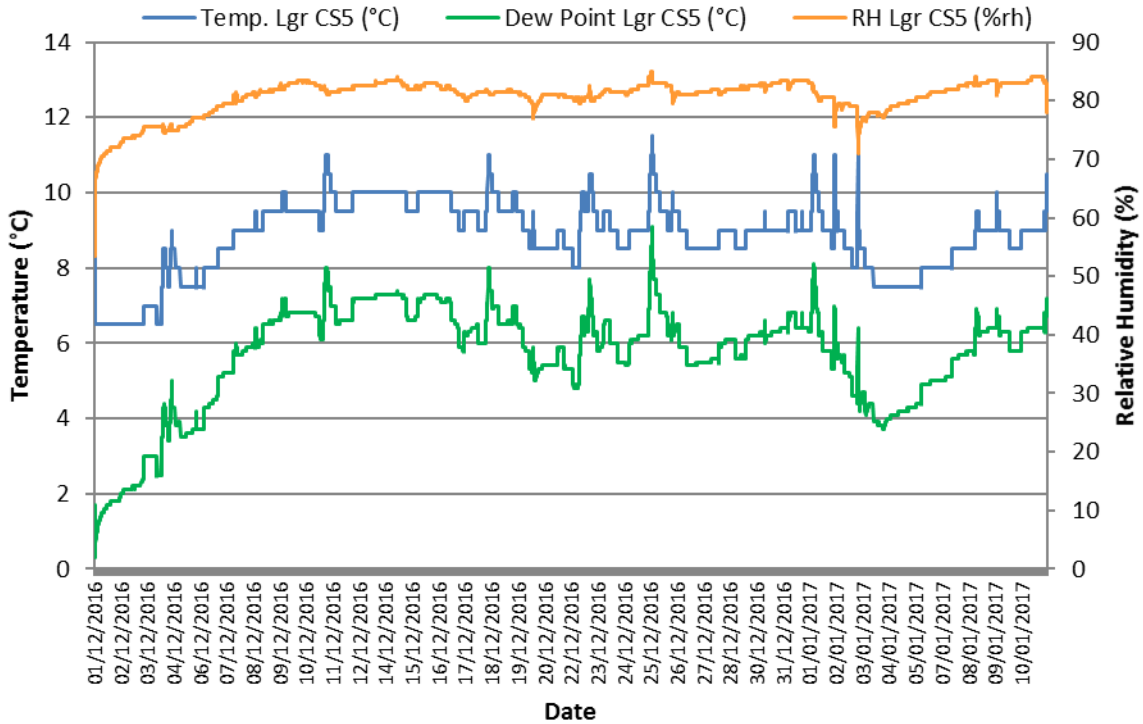

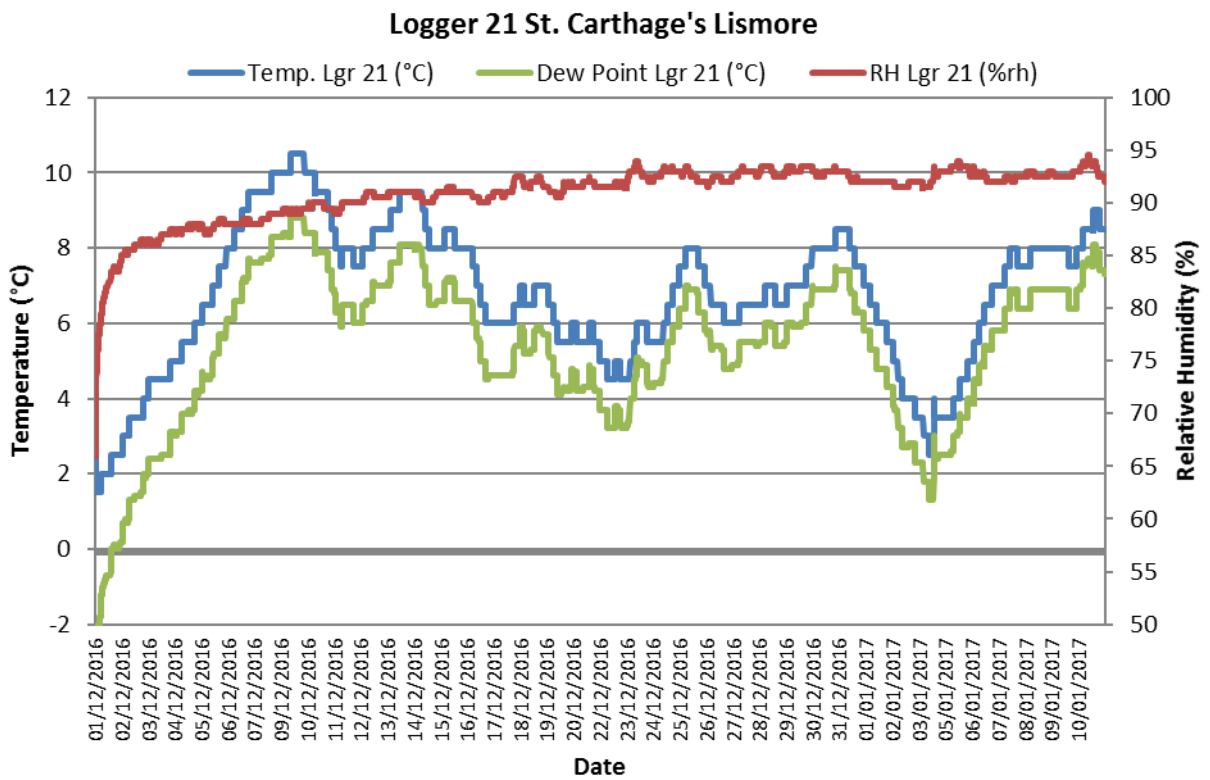

Appendix 20.3 – Tinytag graph (outside T and RH)

TT3 Lismore 12/16

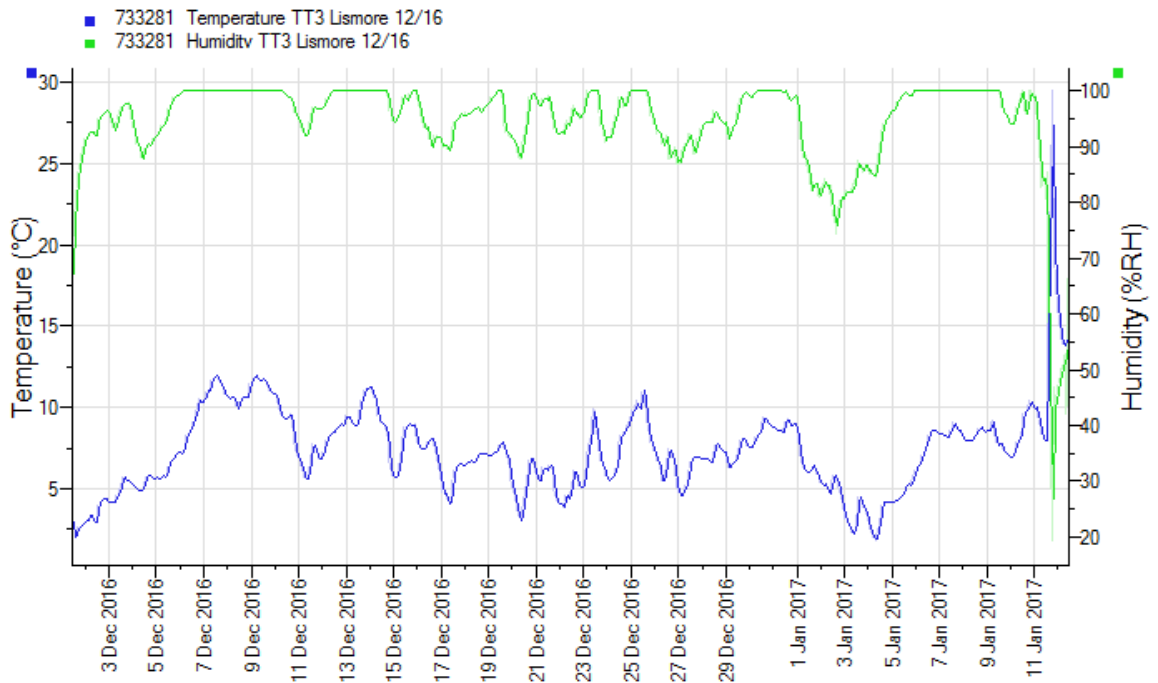

Appendix 21 – St. Macartin's Church of Ireland Cathedral



Enniskillen

Name: The Cathedral Church of St. Macartin.

Location: Enniskillen, Northern Ireland.

Tradition: Church of Ireland.

Outline history: Enniskillen has always been a strategically important town with its location on an island in the River Earn. The island was granted borough status by the English King James I in 1611 since which time it has been a Protestant stronghold through many turbulent events. The first church, dedicated to St. Anne was built on this site in 1627 but the only part of this earlier church still visible in a small part of the tower of the present cathedral. St. Anne's was given cathedral status in 1923 as a result of the expansion of the town but this presented a problem because the diocese of Clogher in which Enniskillen is situated, already had a cathedral. When the new cathedral was dedicated the dedication was changed from St. Anne to St. Macartin which caused even more confusion since Clogher cathedral is dedicated to St. Macartin. Having two cathedrals in one diocese is not technically possible and whilst Enniskillen is a much larger town than Clogher, the position of Enniskillen cathedral is somewhat ambiguous. The present cathedral contains many monuments to eminent Enniskillen people as well as a number of flags and memorials to Irish regiments of the British Army. This cruciform cathedral has a balcony which will produce very complex air movements within the building. The floor is tiles and the walls are stone with plaster and paint on the inside. The ceiling is wooden and painted with no details concerning the void between the ceiling and the roof. The balcony is also wooden with painted underside. There is a lot of wood inside the building including the balcony and the pews. The windows are single glazed with storm glazing on the outside.

Appendix 21.1 – Floor plan with loggers and TinyTag location

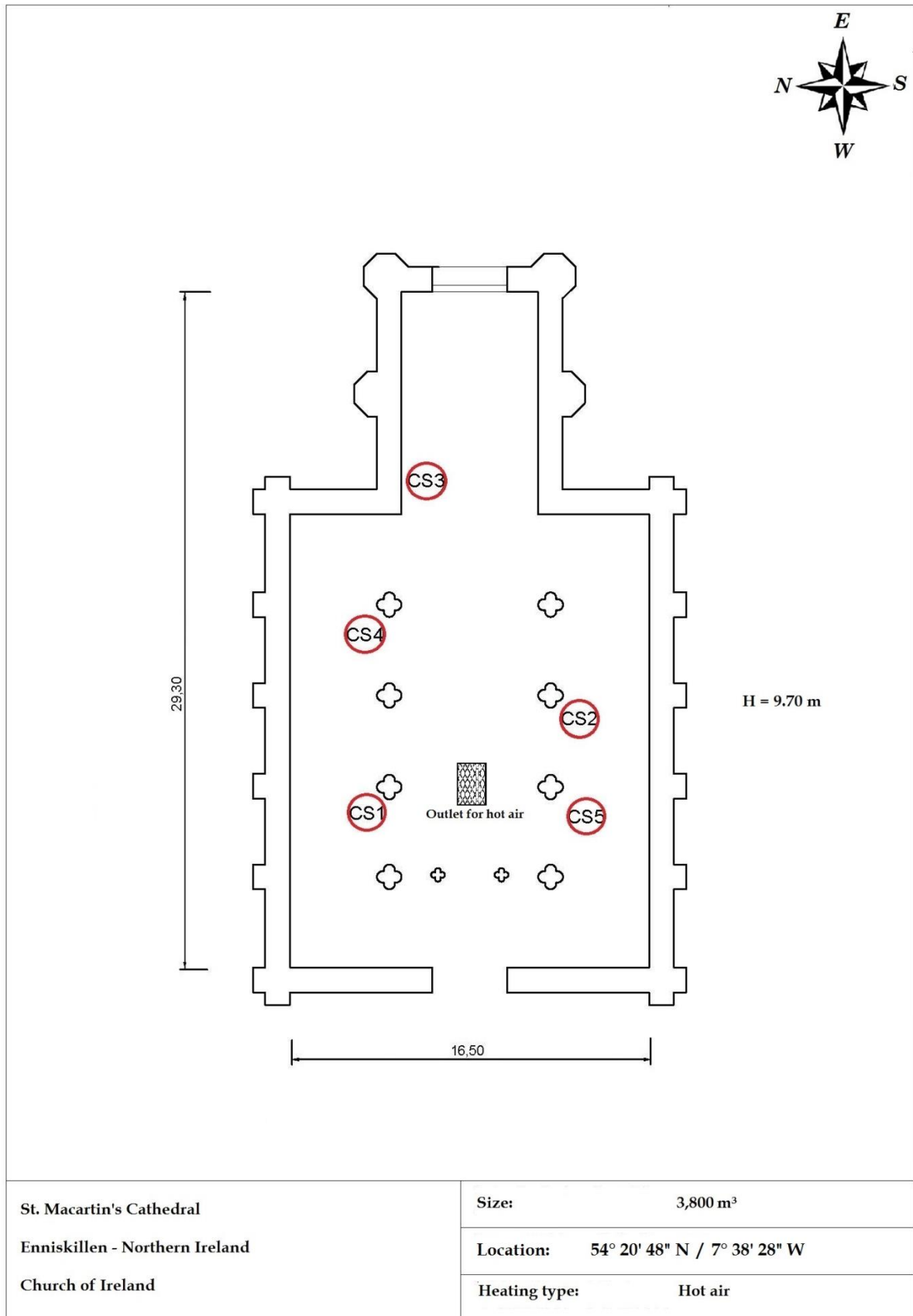

Appendix 21.2 – Loggers' graphs

Logger CS1 St. Macartin's Enniskillen

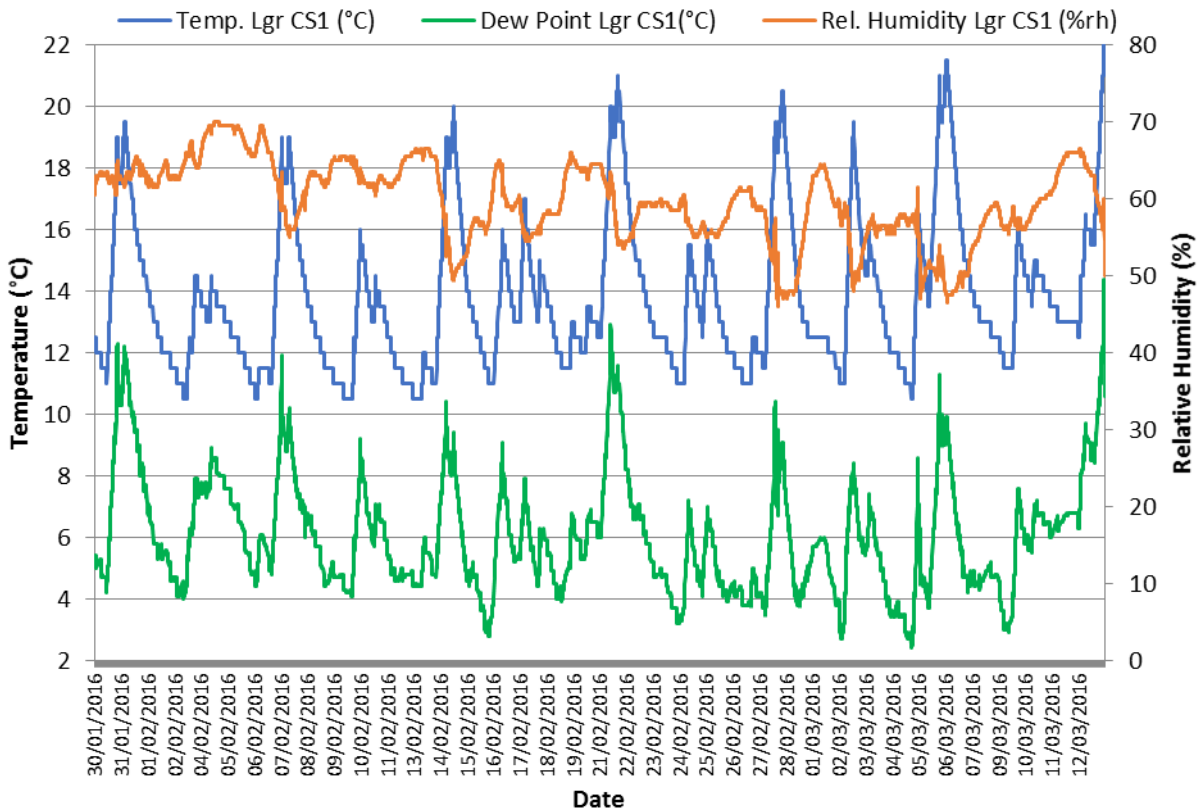

1

Logger CS2 St. Macartin's Enniskillen

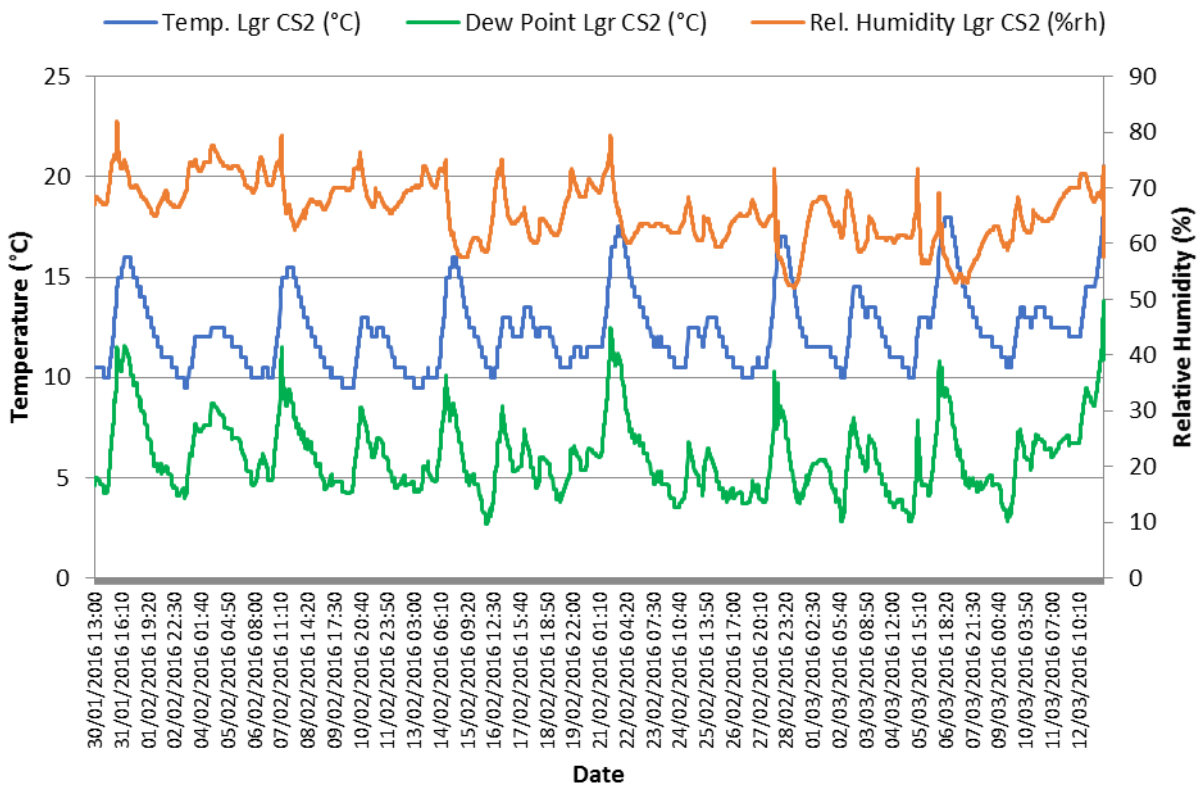

Logger CS3 St. Macartin's Enniskillen

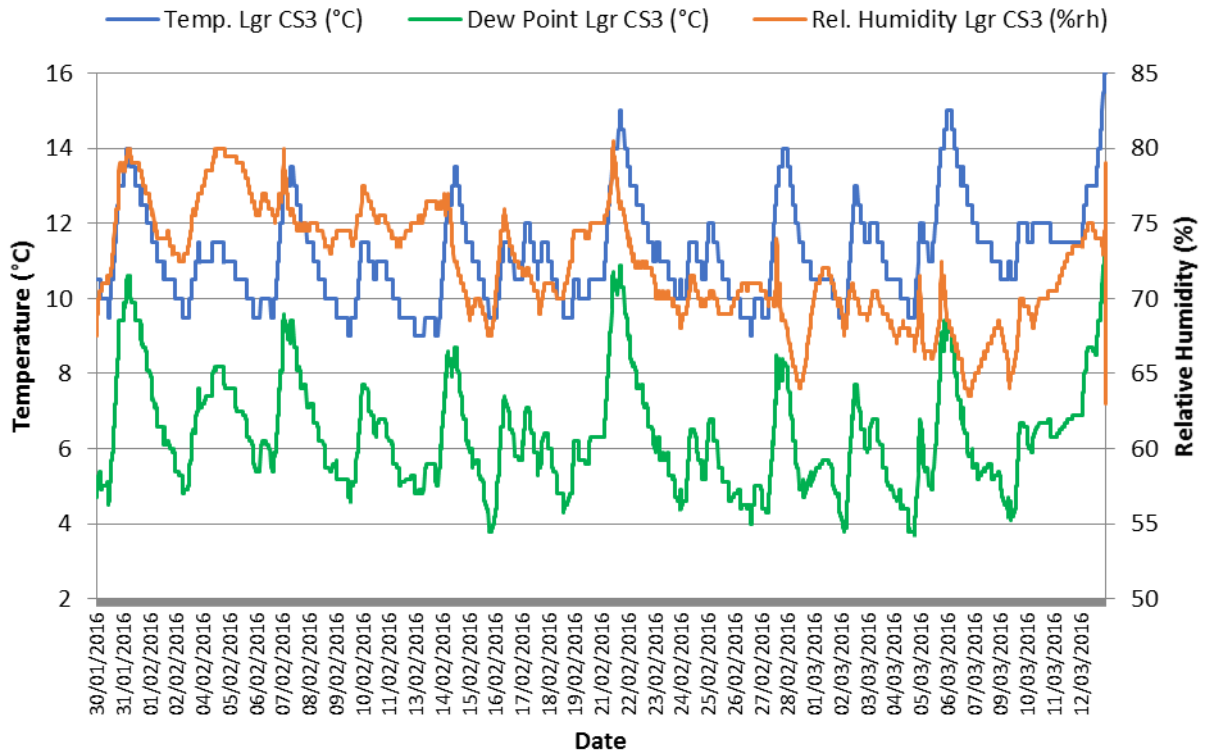

Logger CS4 St. Macartin's Enniskillen

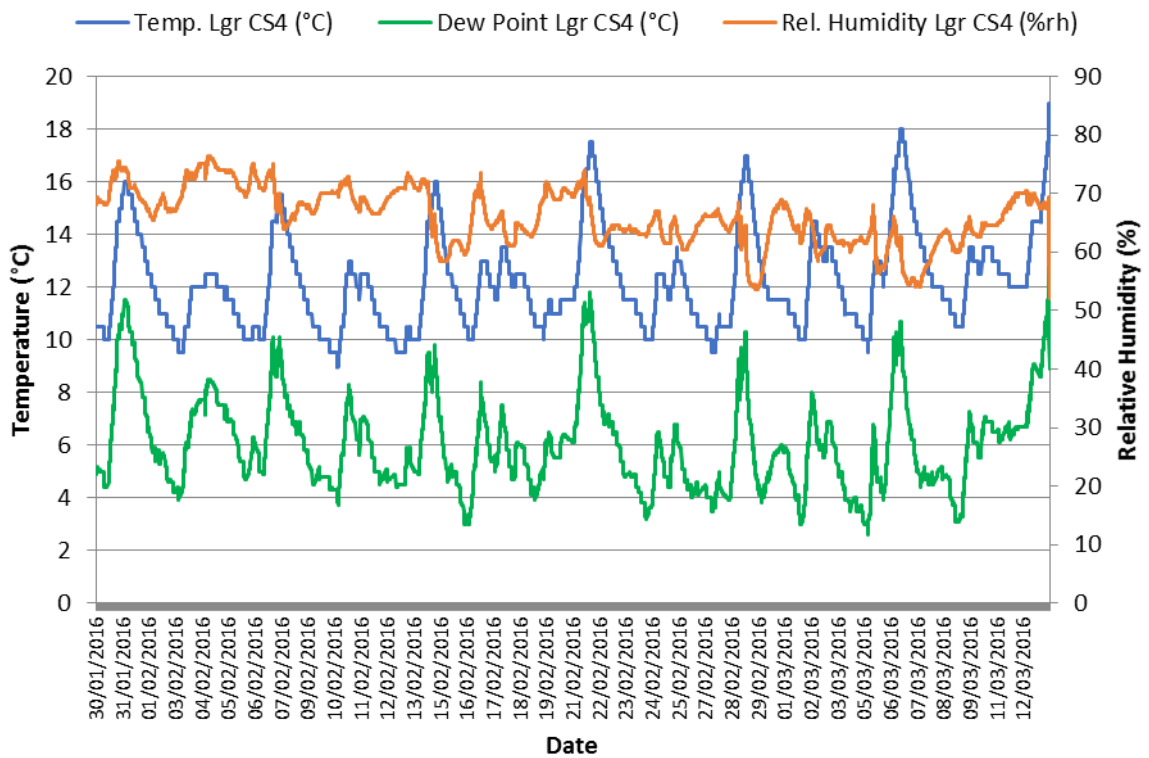

Logger CS5 St. Macartin's Enniskillen

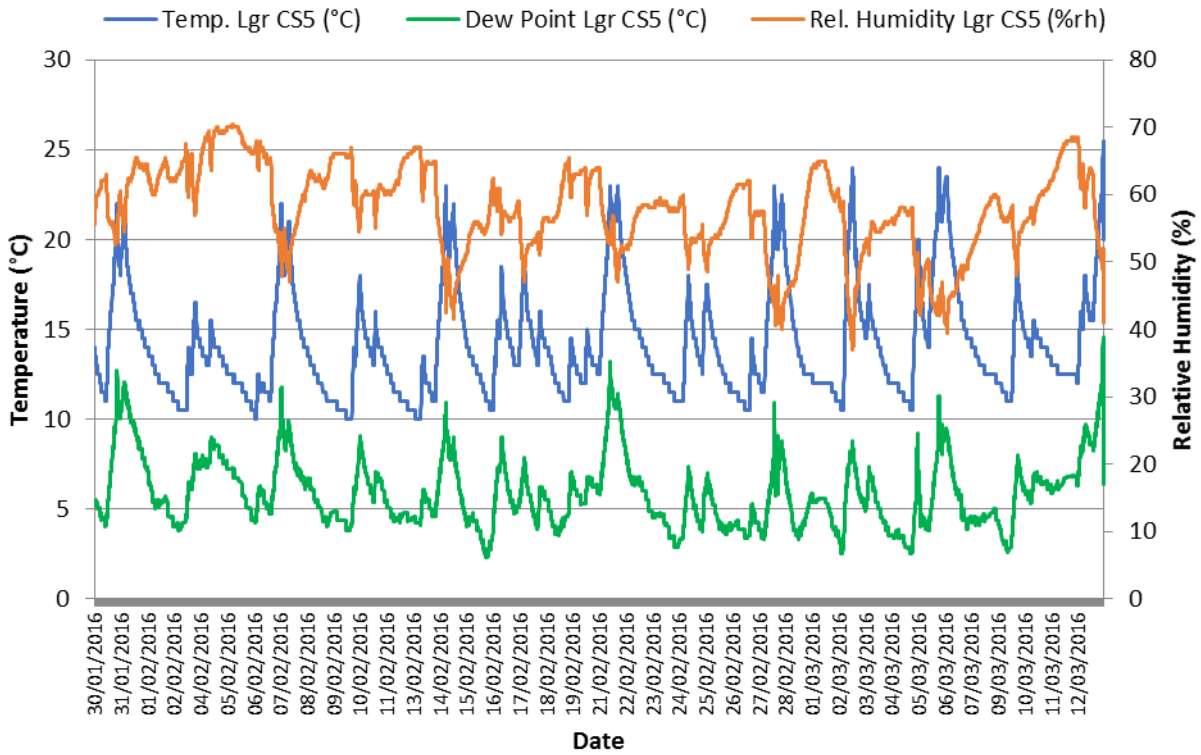

Appendix 21.3 – Tinytag graph (outside T and RH)

TT2 Enniskillen 01/16

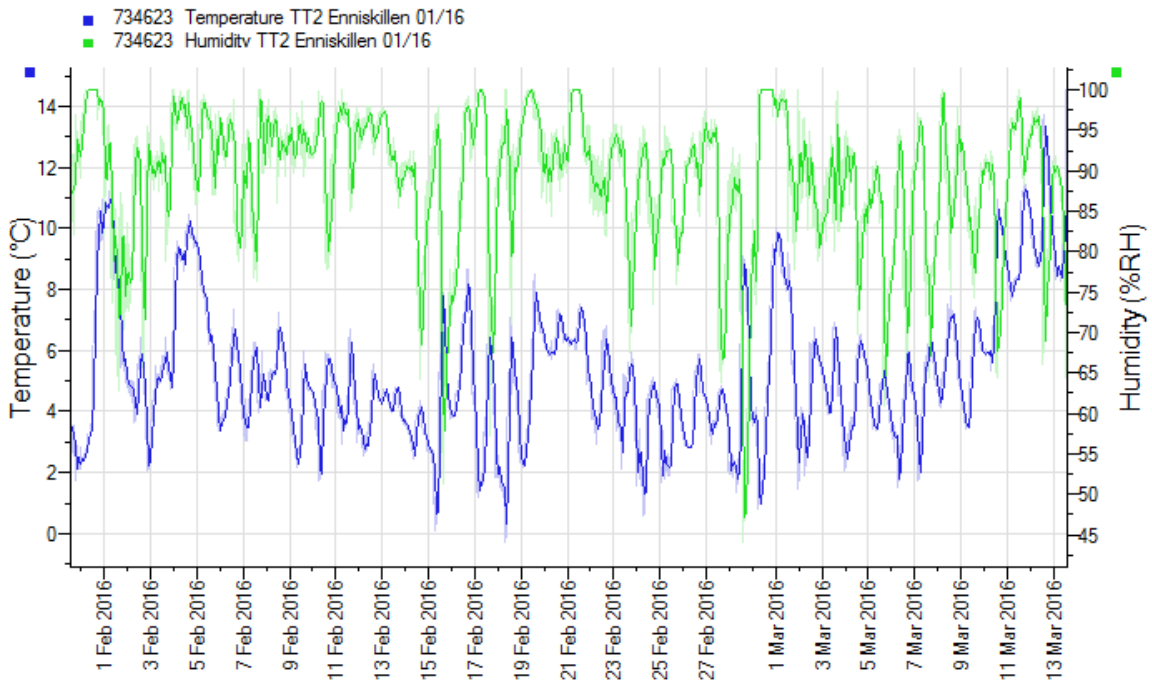

Appendix 22 – St. Brigid’s Church of Ireland Cathedral

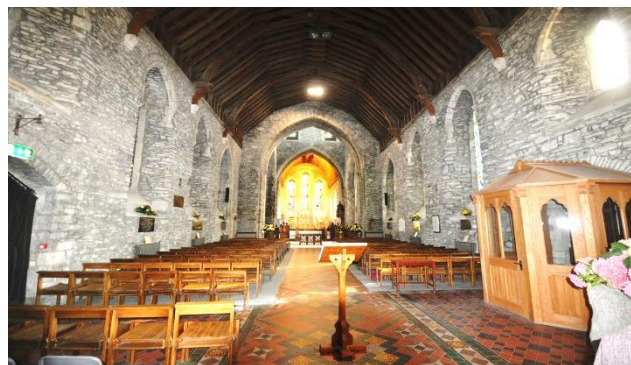

Kildare

Name: Cathedral Church of St. Brigid's.

Location: Kildare City, Republic of Ireland.

Tradition: Church of Ireland.

Outline history:

St. Brigid, to whom the present cathedral is dedicated, was born in 453 and in 480 she moved to Kildare to found a monastery. She died circa 521-528. She is famous throughout Ireland although not many facts of known of her life except her piety and devotion to animals and the poor. The first church in Kildare is ascribed to the year 630 and a cathedral was constructed on the site in around 1223. Over the centuries and as a result of dishonest Bishops and civil strife, the cathedral was in sate of collapse by the start of the 1600s. Some major repairs were carried out in the 1700s but in 1869 the decision was taken to demolish the existing building and build a new one under the architect George Street who was rebuilding Christ Church cathedral in Dublin at the time. Funding was very tight but the building was completed by 1896. Beside the cathedral is a round tower, which is reputed to be one of the finest in Ireland. This tower provides much need tourist income to the cathedral. The number of Protestant families in Kildare has decreased over the years which places an enormous strain on them to maintain the building. The cathedral contains some fine monuments particularly to members of the Fitzgerald family who are buried just outside the building and who were earls of Kildare and later Dukes of Leinster. The stone walls are not plastered on the inside. The floor is made of stone and tiles. The ceiling is wooden and the windows are single glazed stained glass with storm glazing on the outside.

Appendix 22.1 – Floor plan with loggers and TinyTag location

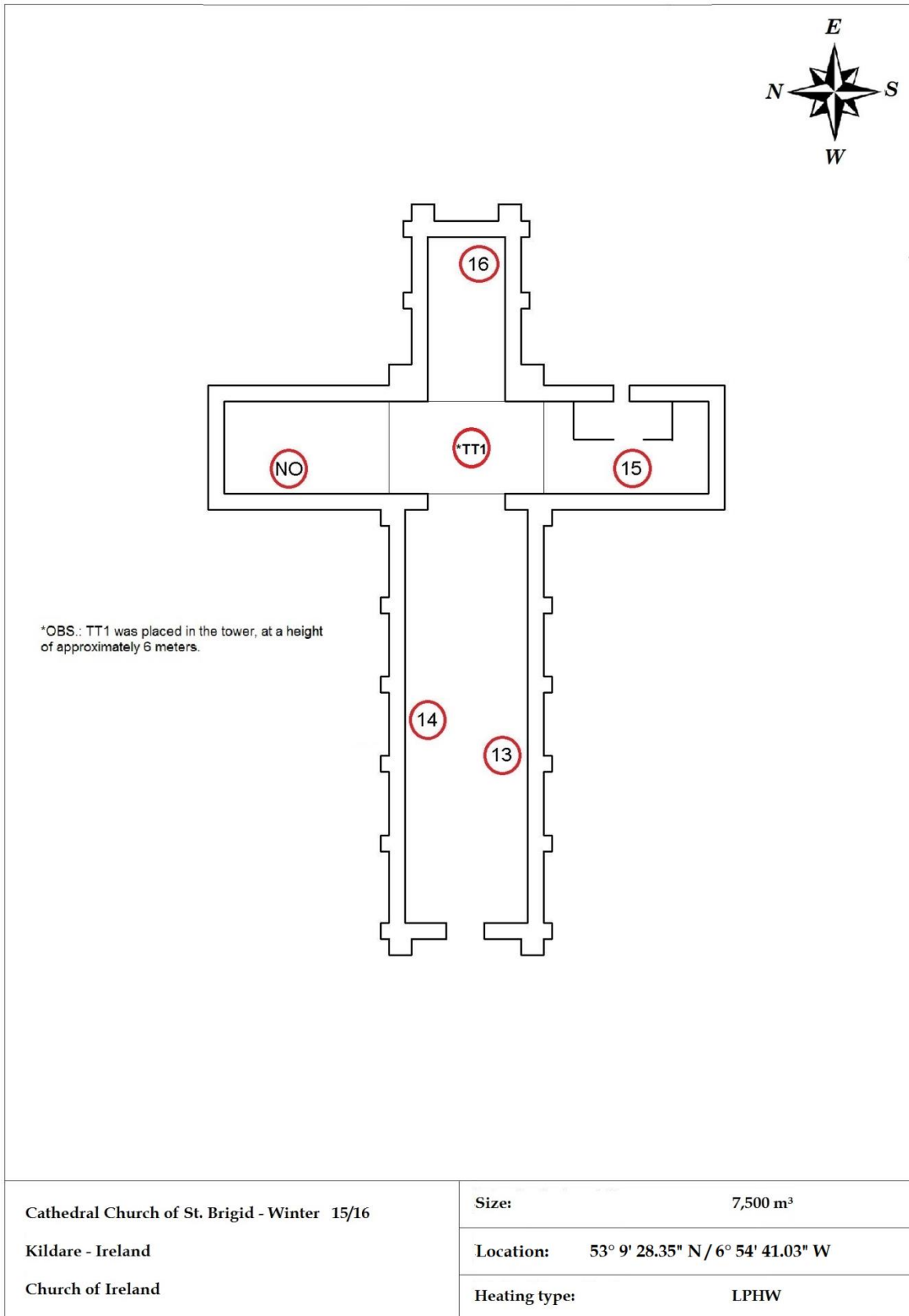

Appendix 22.2 – Loggers' graphs

Logger 13 St. Brigid's Kildare

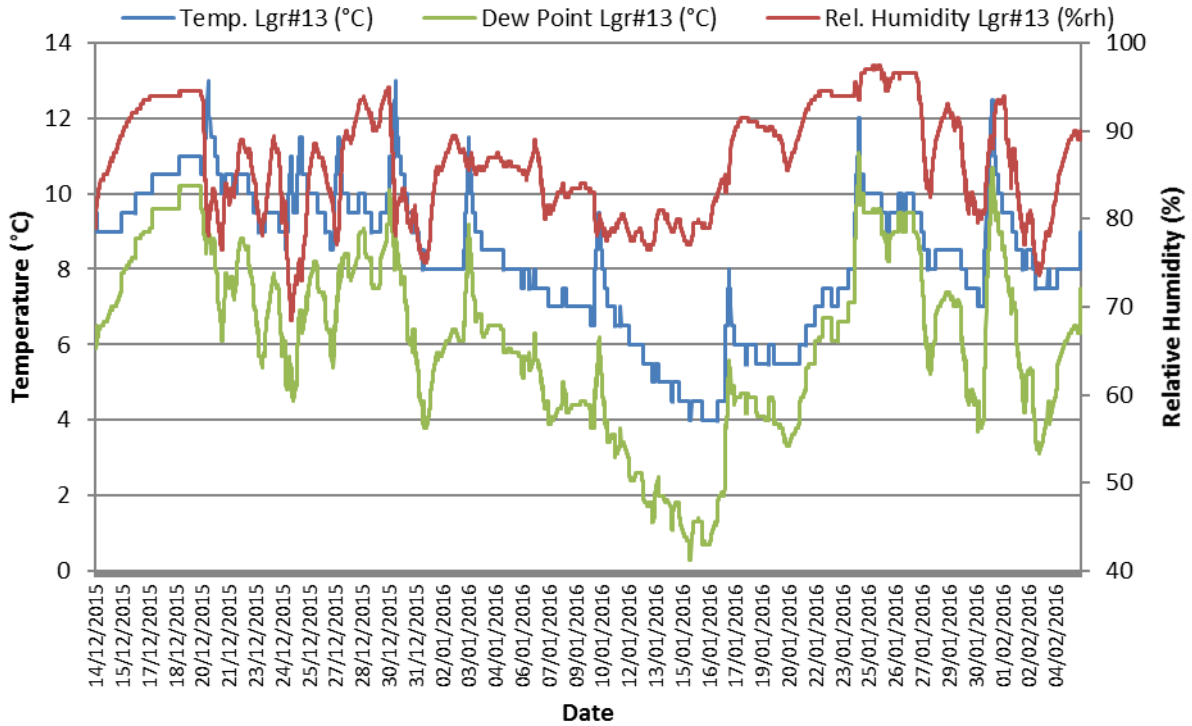

Logger 14 St. Brigid's Kildare

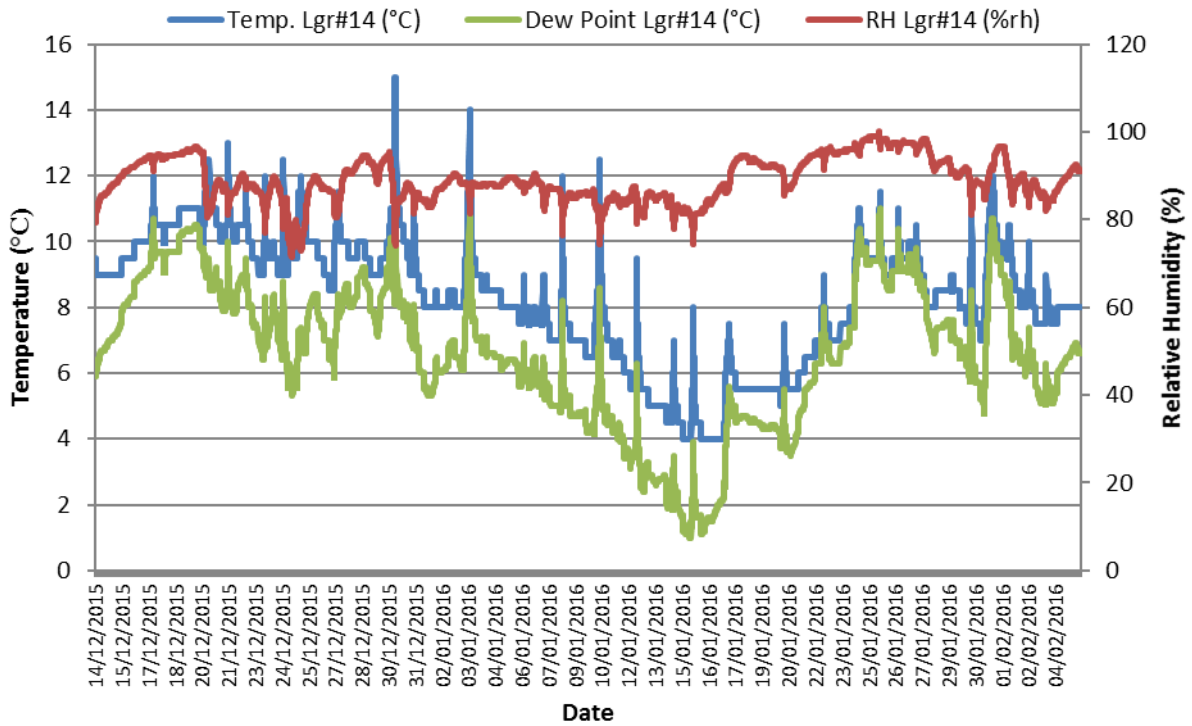

Logger15 St. Brigid's Kildare

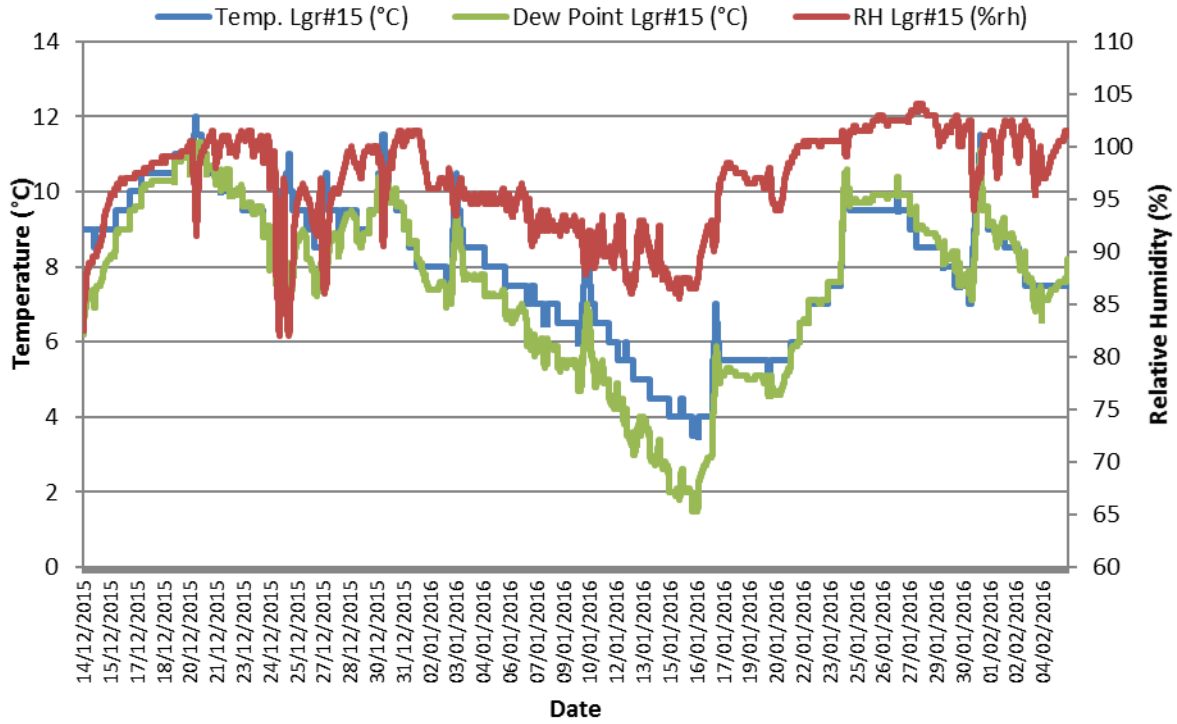

Logger 16 St. Brigid's Kildare

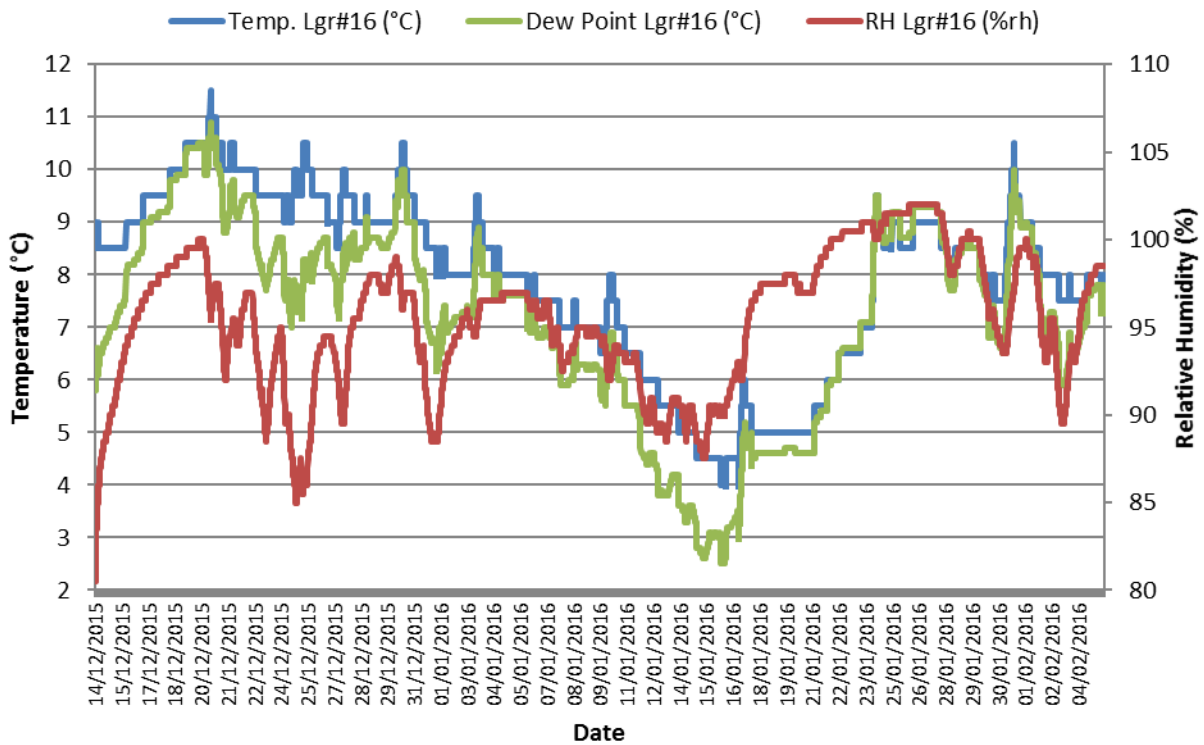

Logger NoN^o St. Brigid's Kildare

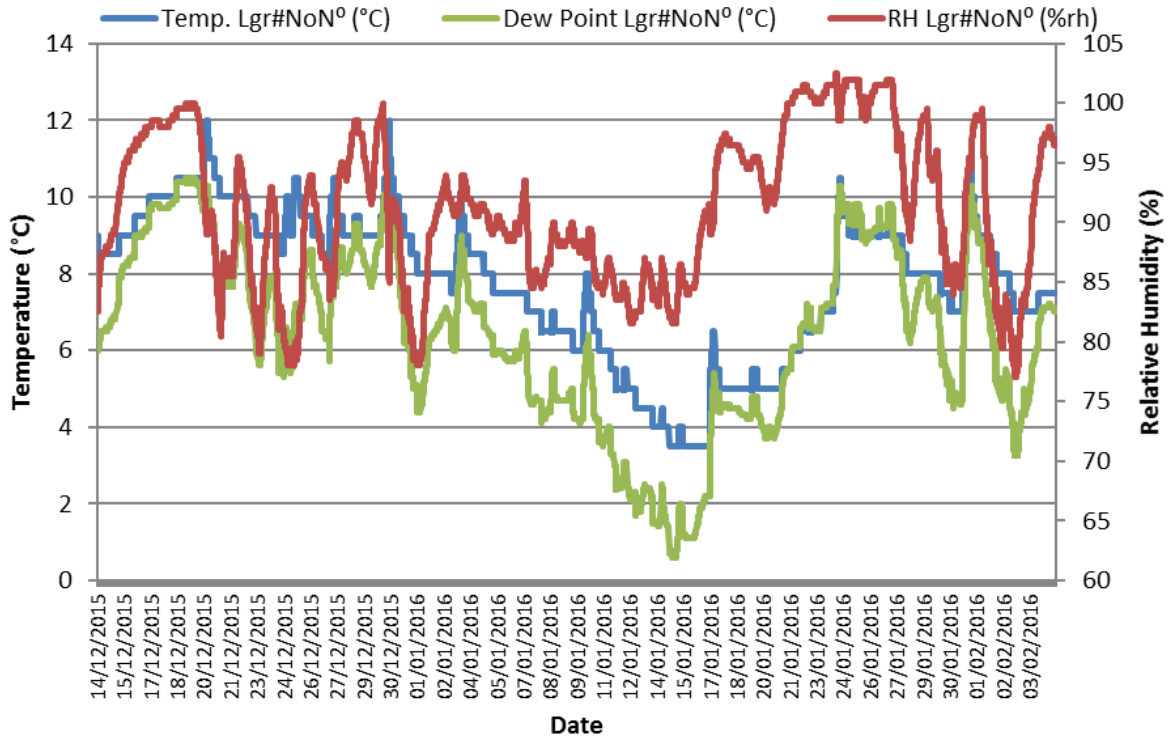

Appendix 22.3 – Tinytag graph (outside T and RH)

TT1 Kildare

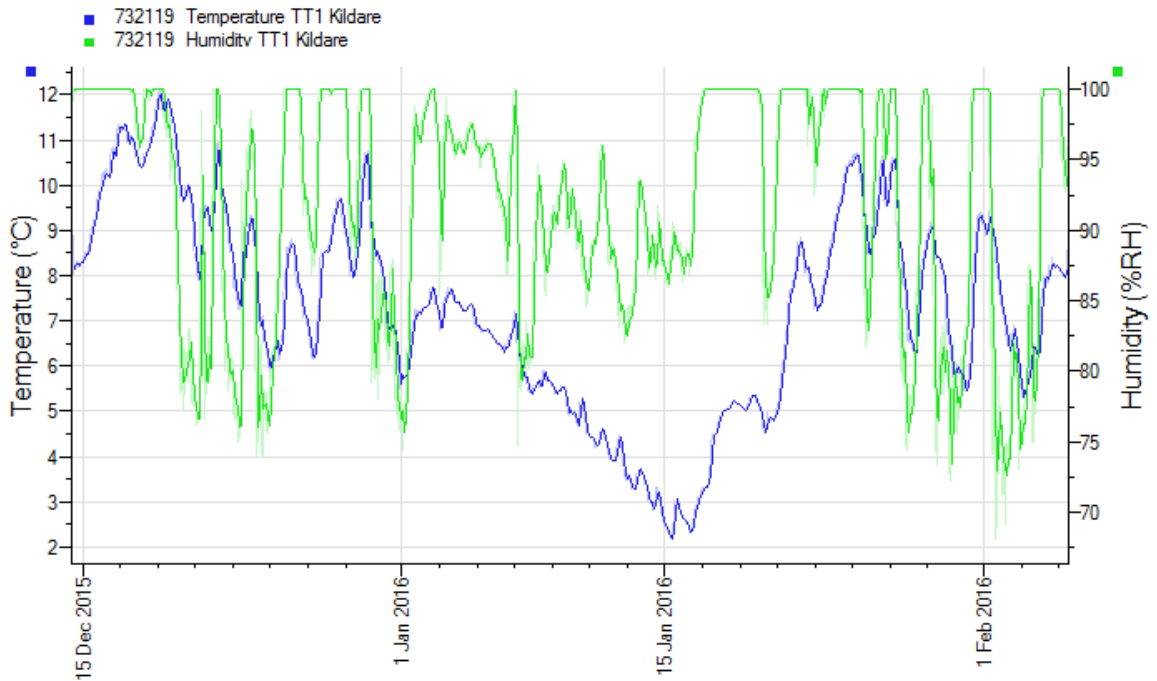

Appendix 23 – Roman Catholic Cathedral Church of the Assumption



View of the Nave. (By: Andreas F. Borchert. License: CC BY-SA 3.0 de)

Carlow

Name: The Cathedral Church of the Assumption.

Location: Carlow, Republic of Ireland.

Tradition: Roman Catholic.

Outline history: Carlow cathedral was the first Roman Catholic cathedral to be built after Catholic Emancipation in 1829 with the cathedral being completed in 1833. The Catholic Emancipation Act of 1829 removed many of the restrictions which had been placed on Roman Catholics and their worship over many years by the United Kingdom parliament. The driving force behind the building of the cathedral was Bishop James Doyle and a large memorial to him can be found in the cathedral today on the North side of the Nave. Unfortunately Bishop Doyle died the year after the cathedral was completed, in 1834. There had been a Pro cathedral in Carlow since 1752. The building is of the Gothic Revival architectural style and is the cathedral of the Diocese of Kildare and Old Leighlin. Carlow is a town which was situated on the edge of the Pale and this is referred to in Chapter 4.

The cathedral has links with Bruges in Belgium as the Bishop's throne or cathedra and the pulpit came from there. It is also thought that the distinctive lantern tower of the cathedral was modelled on Belfroi Tower in Bruges. The cathedral was substantially refurbished in 1997 and rededicated that year. The cathedral has pillars in the nave but the ceilings in the side aisles are the same height as the nave. The floor is tiles and the walls are stone with plaster and paint on the inside. The ceiling is wooden with plaster and painted. No details are available of the void between the ceiling and the roof.

Appendix 23.1 – Floor plan with the loggers and TinyTag location

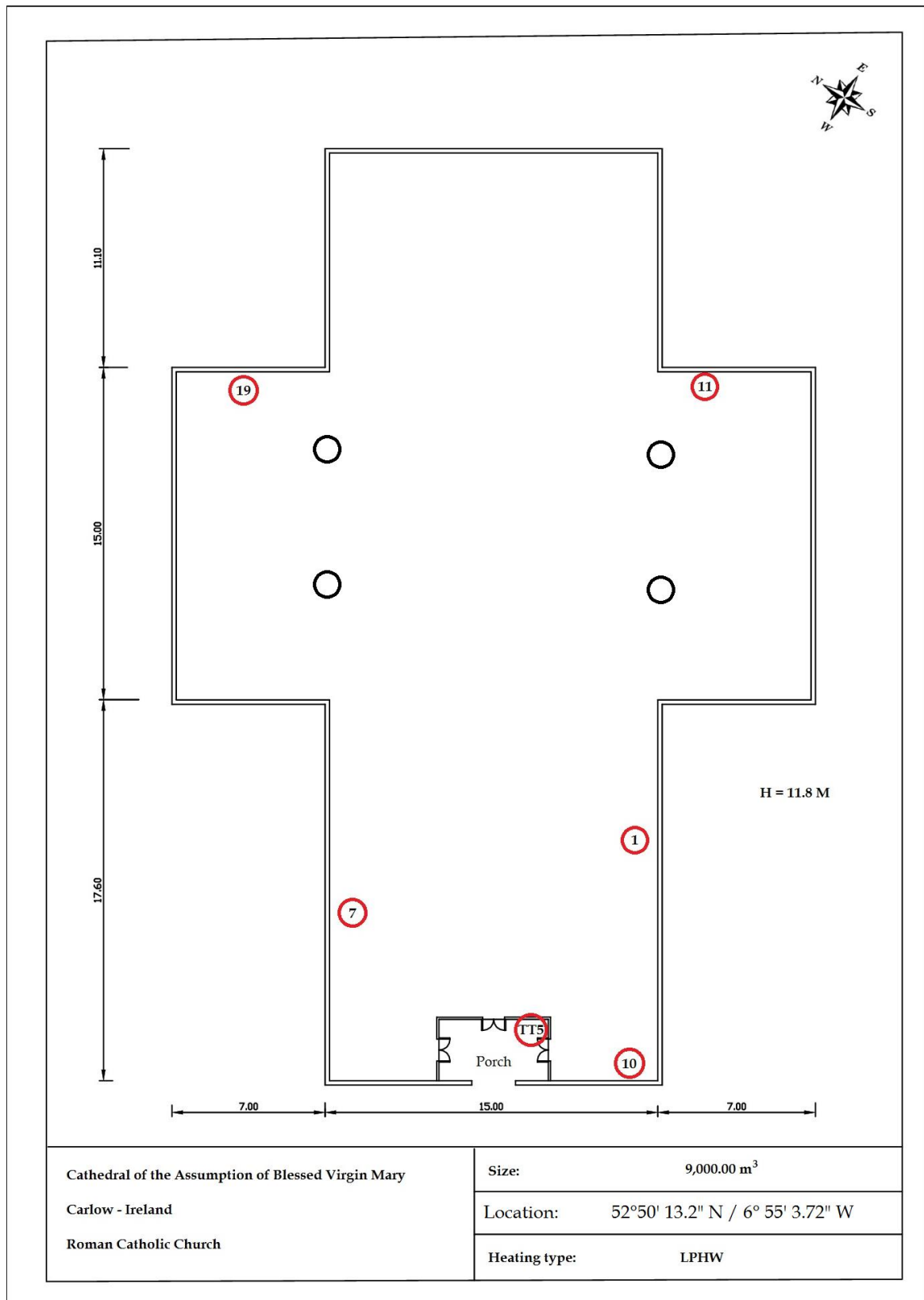

Appendix 23.2 – Loggers’ graphs

Logger 1 Carlow Cathedral

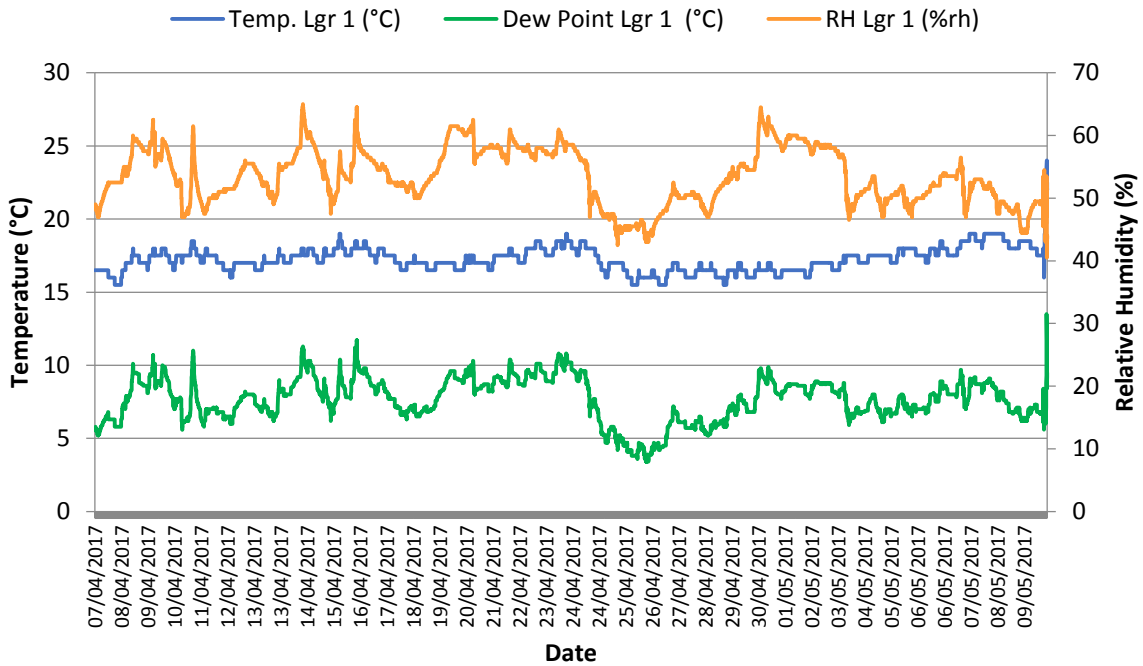

Logger 7 Carlow Cathedral

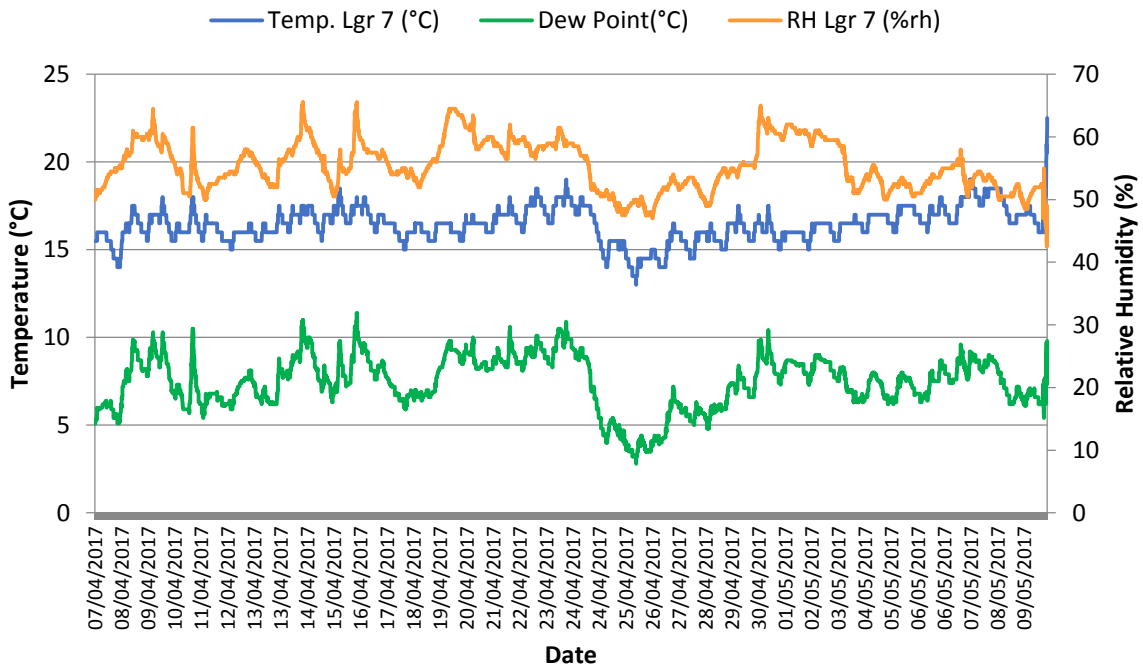

Logger 10 Carlow Cathedral

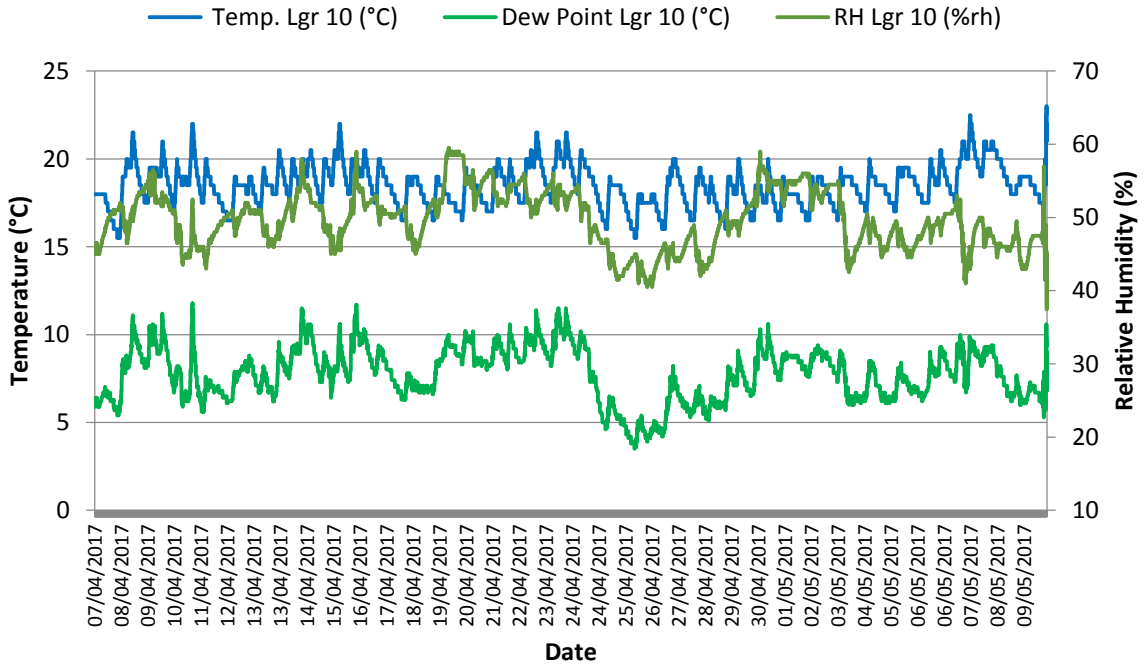

Logger 11 Carlow Cathedral

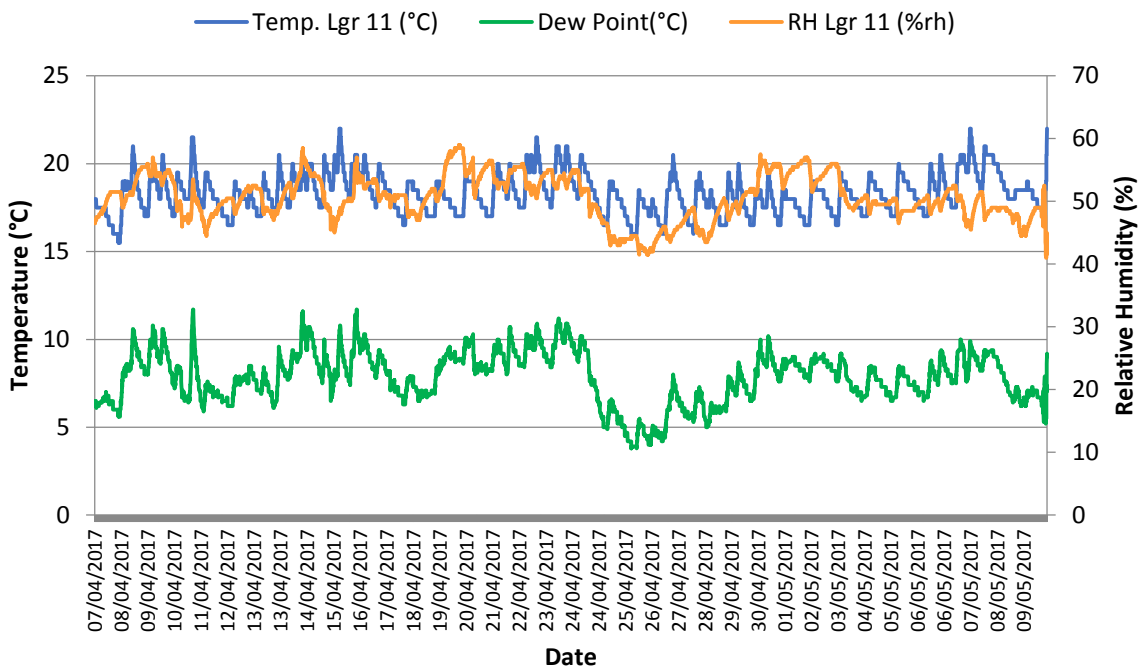

Logger 19 Carlow Cathedral

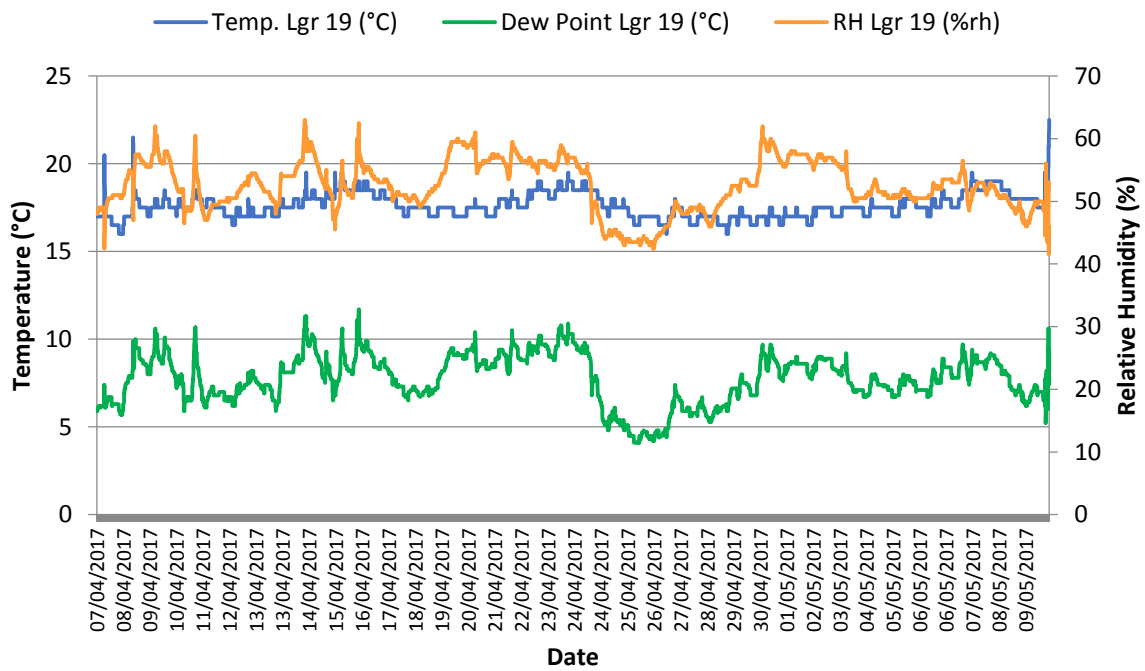

Appendix 23.3 – Tinytag graph

TT5K Carlow

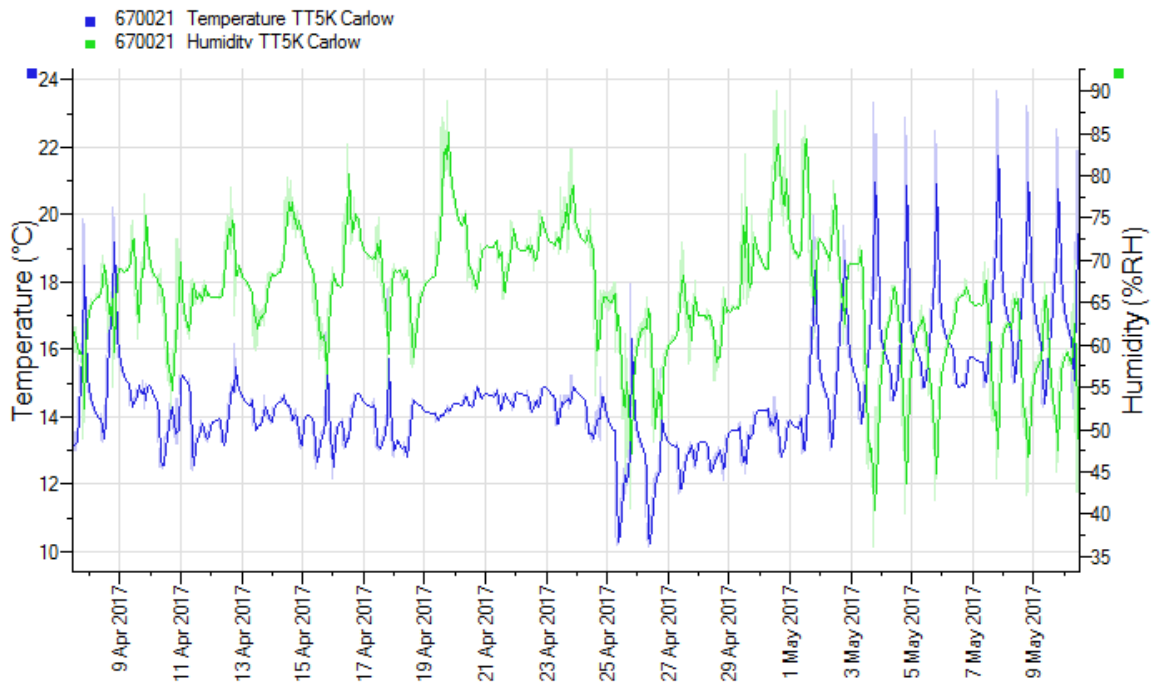

Appendix 24 – Saint Brendan’s Roman Catholic Cathedral



Source: Catholic Heritage blog

[Available at:

<https://catholicheritage.blogspot.ie/2017/05/pilgrimage-to-loughrea-cathedral-2017.html?m=0>]

Loughrea

Name: The cathedral Church of St. Brendan.

Location: Loughrea town, Republic of Ireland.

Tradition: Roman Catholic.

Outline history: Loughrea cathedral the north shore of Lough Rea is close to the centre of the town. The site has had both a castle, a small portion of which can still be seen today and a Carmelite Friary on it previously. The cathedral was started in 1897 and was completed in 1902. It is Gothic in design, quite small in size and is generally recognised as being plain on the outside. What makes this cathedral stand out is the interior which is recognised as being one of the best examples of what was known as the Celtic revival which was a renaissance movement in Irish art and design. Inside the cathedral are some of the best examples of Irish carving, woodwork, metalwork and textile design but especially stained glass window design. The stained glass was commissioned from seven designers from what was known as The Tower of Glass stained glass studio. Fortunately the reordering which took place in the mid-1970s as a result of the Second Vatican Council, did not destroy or remove any of the internal fittings and fixtures. This cruciform cathedral has stone walls with plaster and paint on the inside. The ceiling is unpainted wood with what appears to be a small void between the ceiling and the roof. The floor is tiles and the pews are wooden. There is a considerable amount of marble, such as the pillars, within the building.

Appendix 24.1 – Floor plan with loggers and TinyTag location

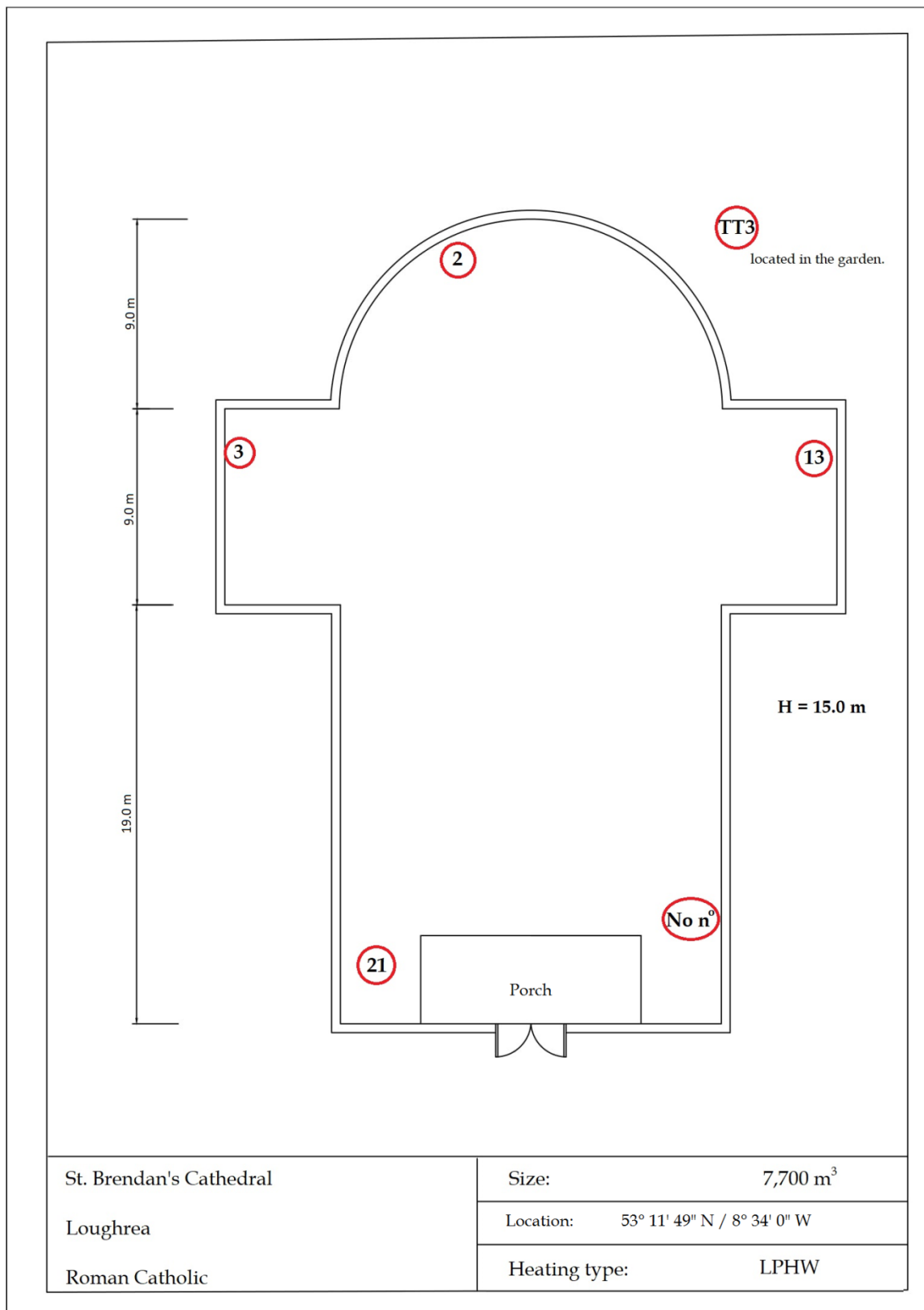

Appendix 24.2 – Loggers' graphs

Logger 2 St. Brendan's Loughrea

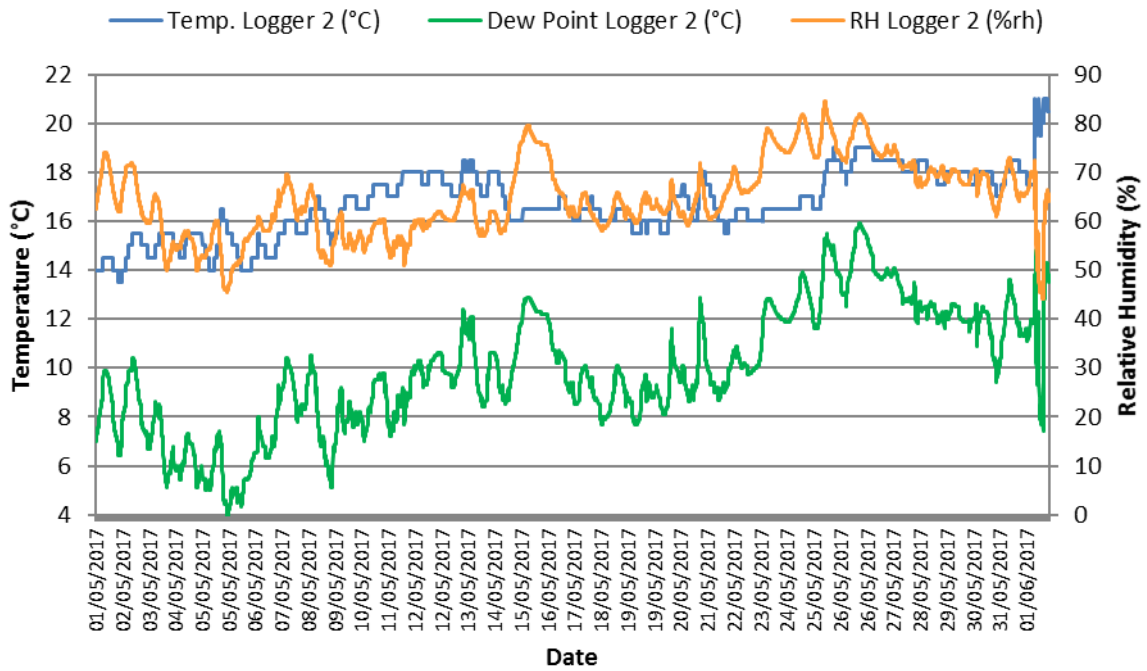

Logger 3 St. Brendan's Loughrea

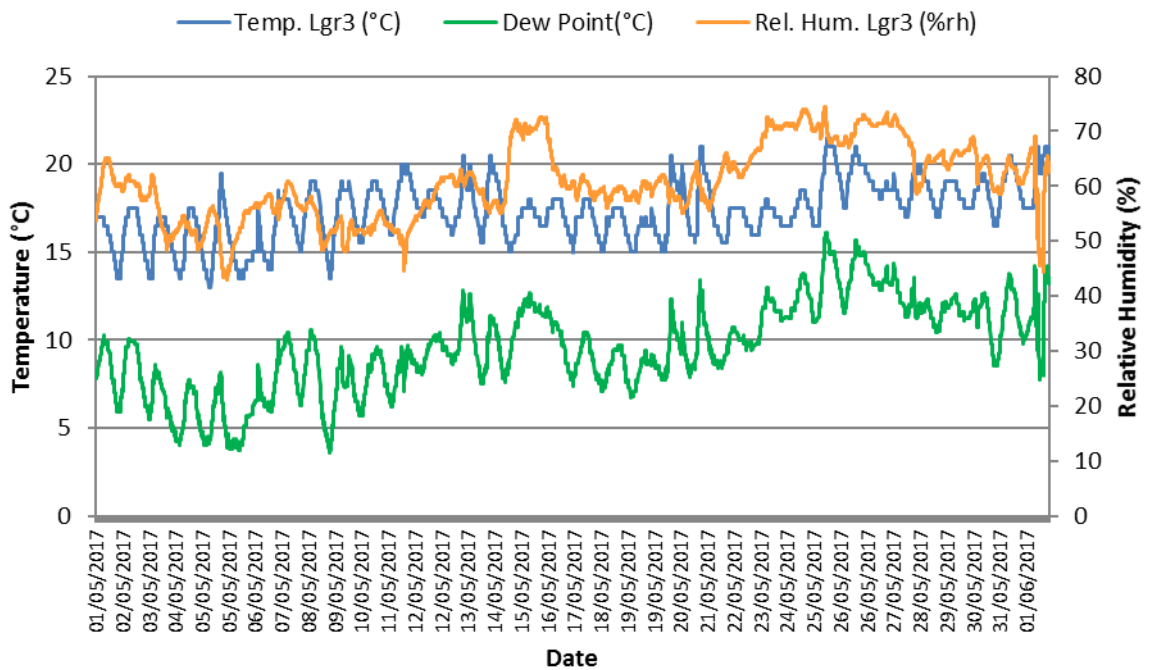

Logger 13 St. Brendan's Loughrea

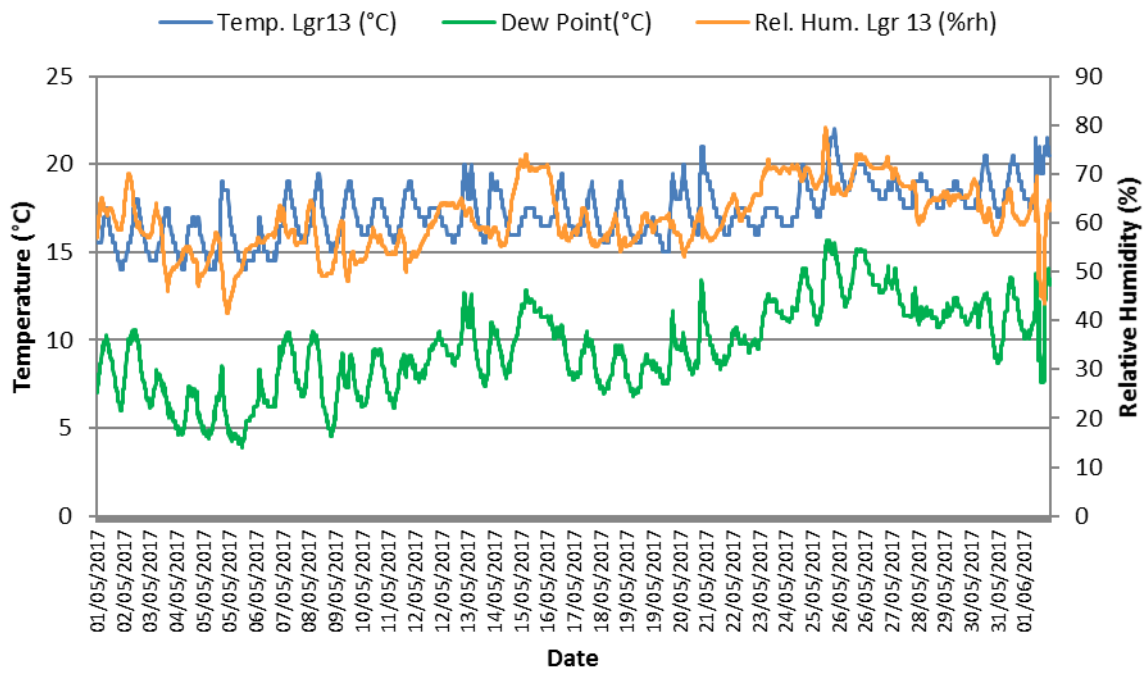

Logger 21 St. Brendan's Loughrea

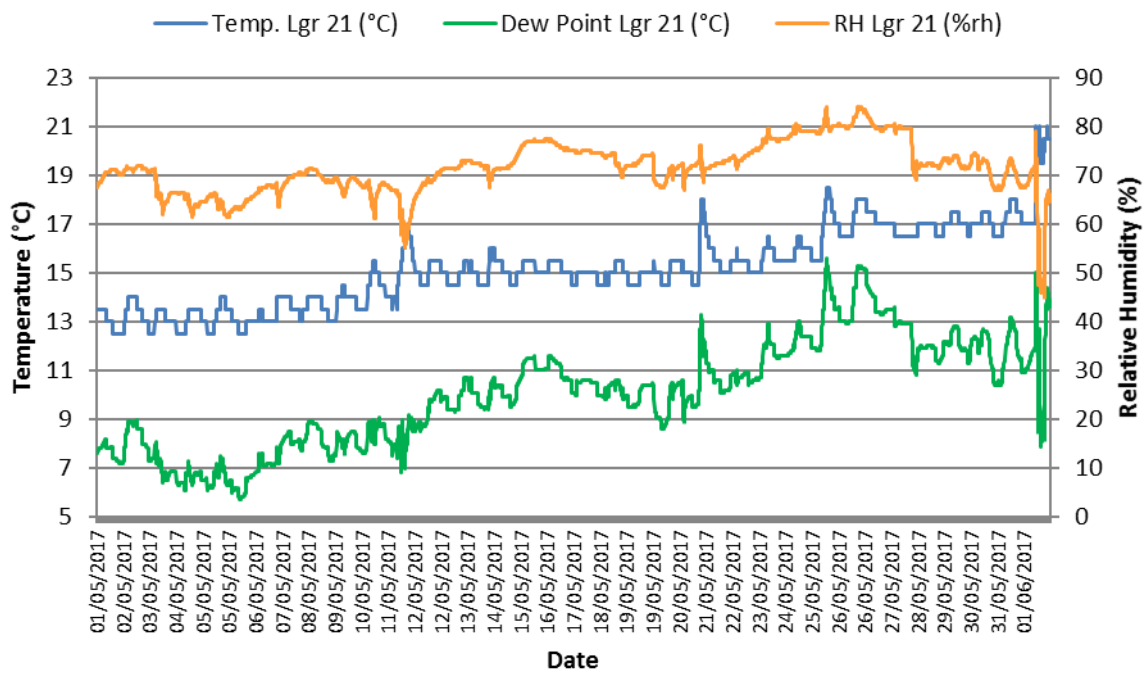

Logger No N° St. Brendan's Loughrea

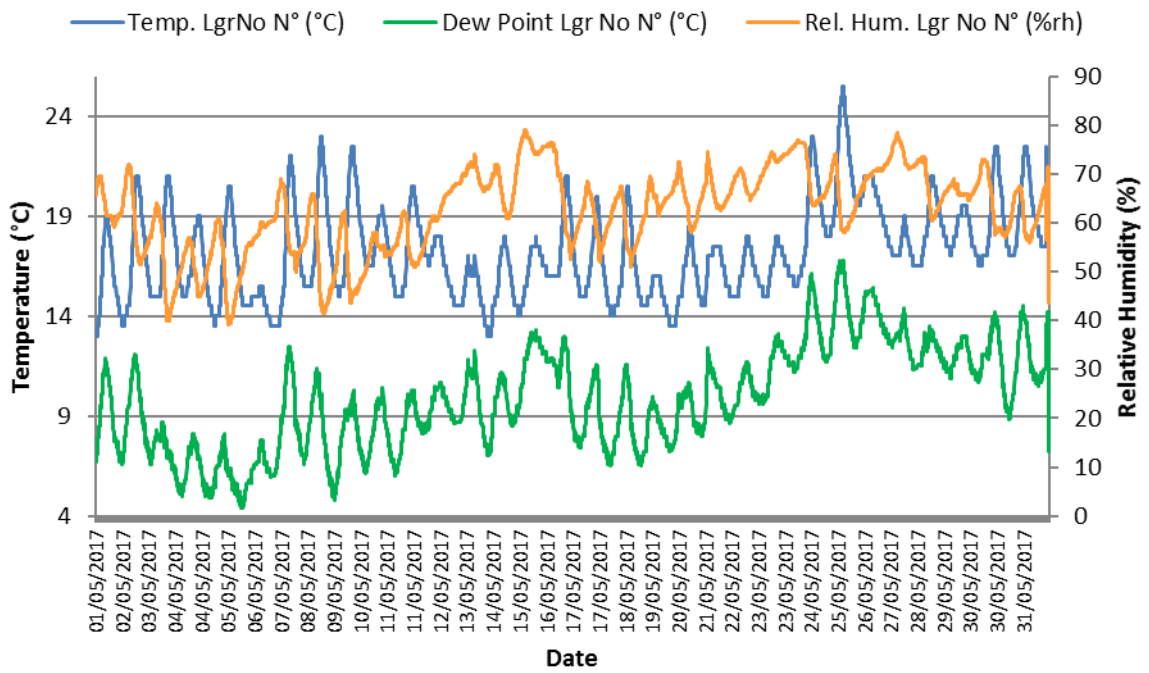

Appendix 24.3 – Tinytag graph (outside T and RH)

TT3 Loughrea

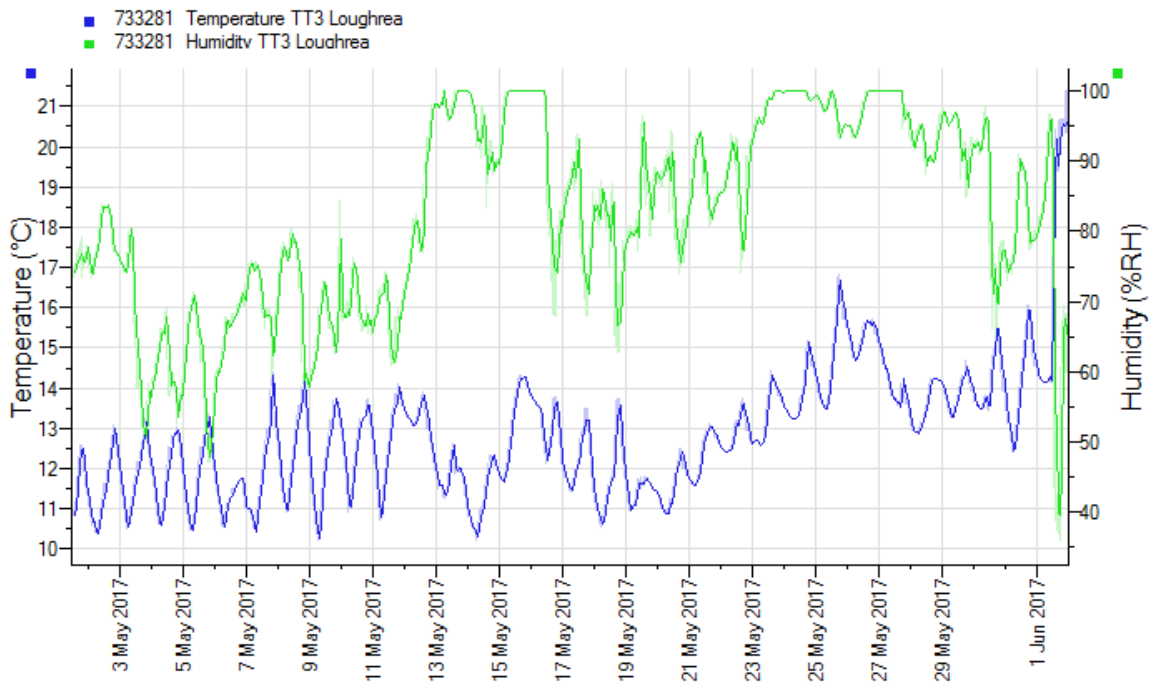

Appendix 25 – St. Patrick’s Roman Catholic Cathedral



Source: GALLOWAY, 1992. P. 198

Skibbereen

Name: The cathedral Church of St. Patrick.

Location: Skibbereen , Republic of Ireland.

Tradition: Roman Catholic.

Outline history: The status of Skibbereen cathedral is not entirely clear. It was a Pro cathedral for many years and then in 1951 was elevated to cathedral status in the diocese of Ross. However in 1958 the diocese of Ross was amalgamated with that of Cork and Cork already had a cathedral namely the Cathedral Church of St. Mary and St. Anne and it is technically not possible to have two cathedrals in one diocese. Skibbereen has however a cathedra inside and it is called a cathedral on the gate and certainly the locals in the town refer to it as a cathedral and so it is included here. The cathedral was built as a parish church in the 1820s within the diocese of the then, Cloyne and Ross. Inside the cathedral are a number of memorials to former bishops. Above the transepts are galleries which increase the seating capacity for what is otherwise quite a small cathedral. This cathedral has a flat painted wooden ceiling with an obvious considerable void between the ceiling and the roof. The walls are stone and the insides are covered in plaster and paint. The floor is tiles. There are many wooden fittings including the pews. There are wooden balconies in the transepts which will affect the air movements within the building. There are considerably quantities of marble around the sanctuary area. The windows are single glazed with external storm glazing.

Appendix 25.1 – Floor plan with loggers and TinyTag location

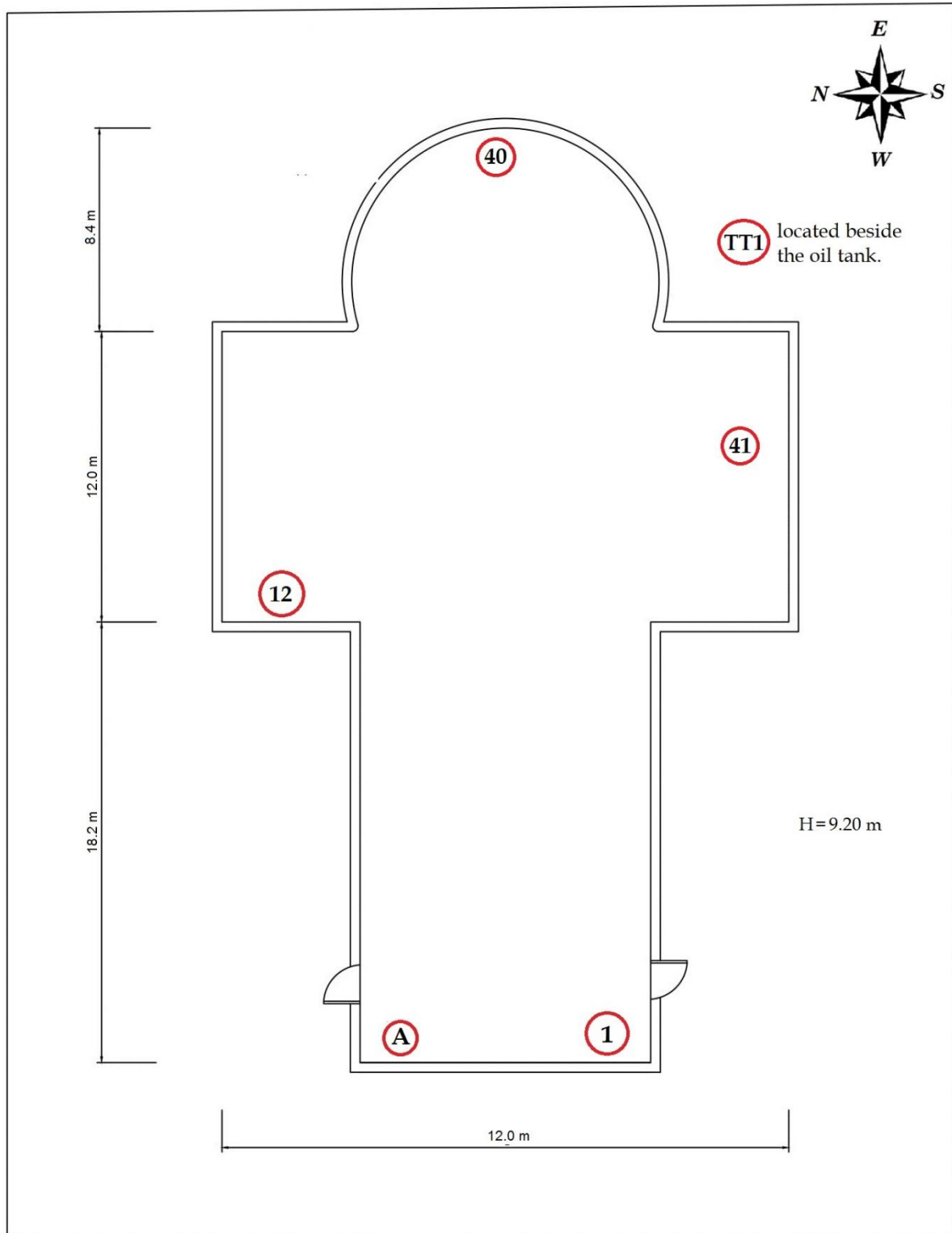

St. Patrick's Cathedral	Size: 5,400 m ³
Skibbereen - Ireland	Location: 51° 54' 16" N / 8° 28' 34" W
Roman Catholic Church	Heating type: LPHW

Appendix 25.2 – Loggers' graphs

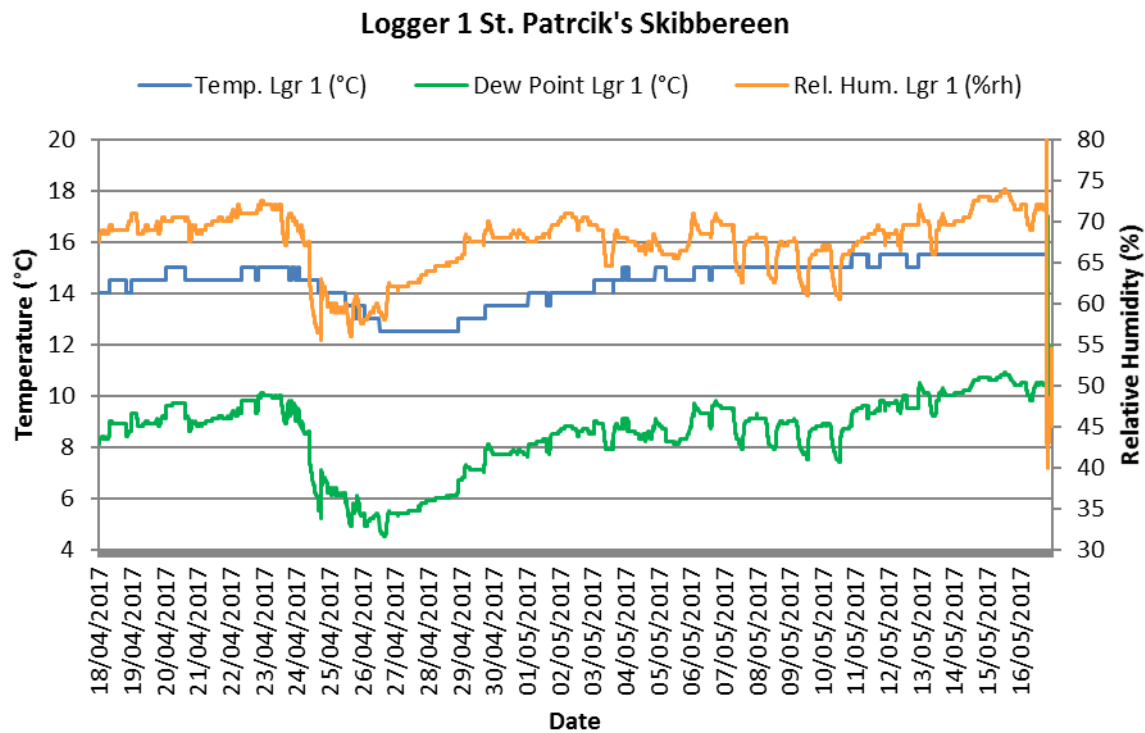
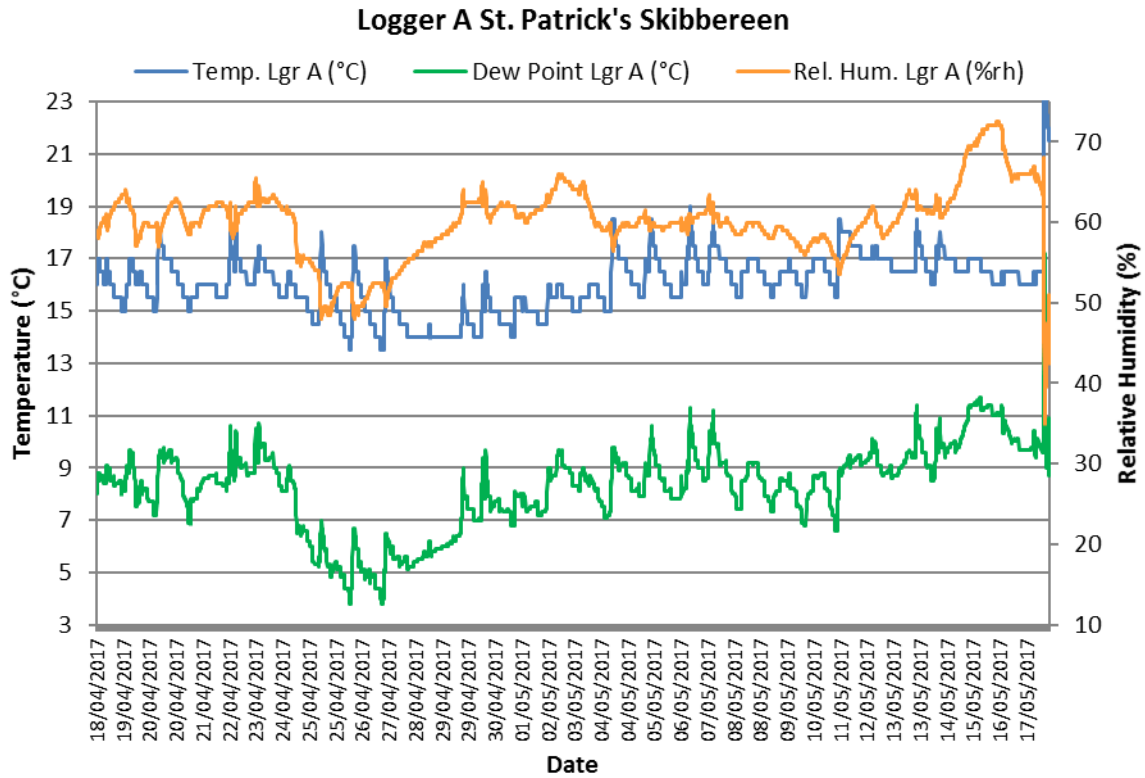

Logger 21 St. Patrick's Skibbereen

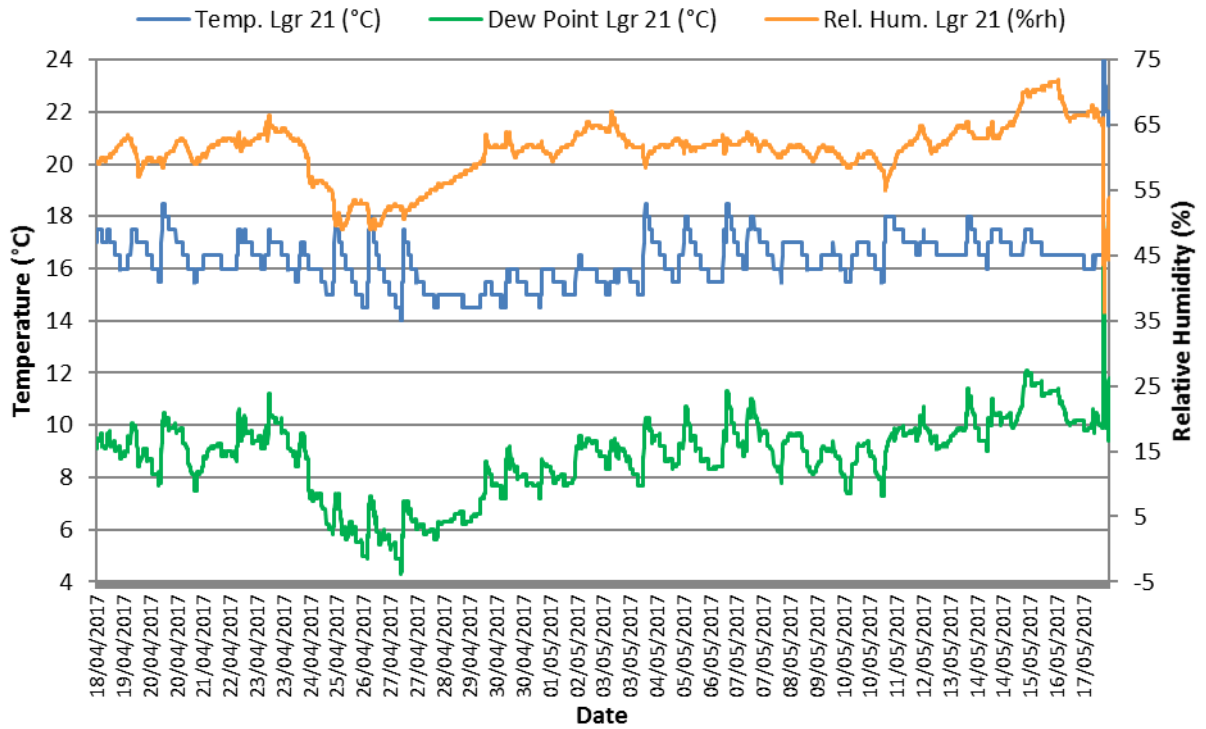

Logger 40 St. Patrick's Skibbereen

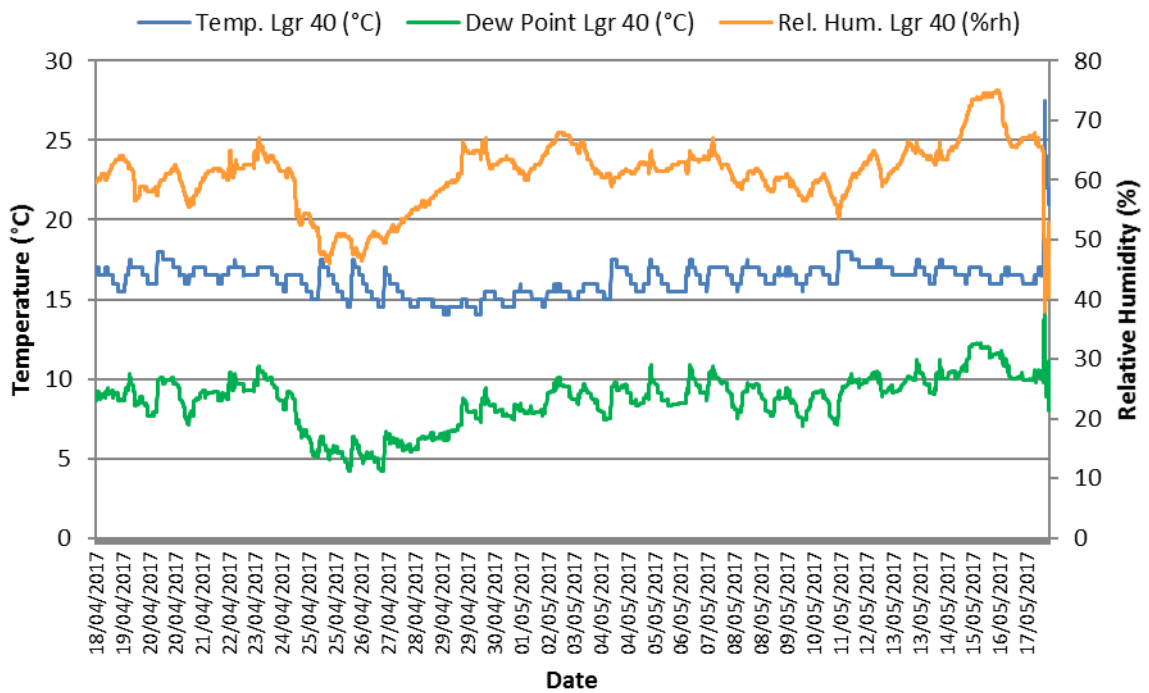

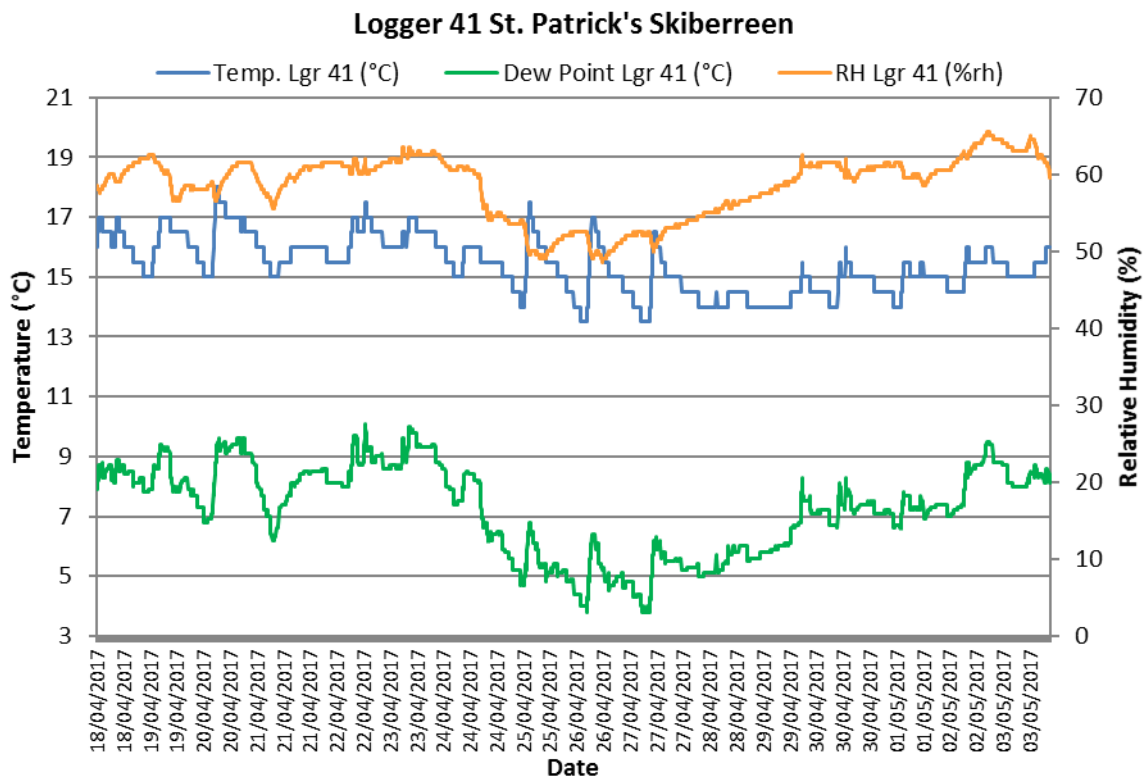

Appendix 25.3 – Tinytag graph (outside T and RH)

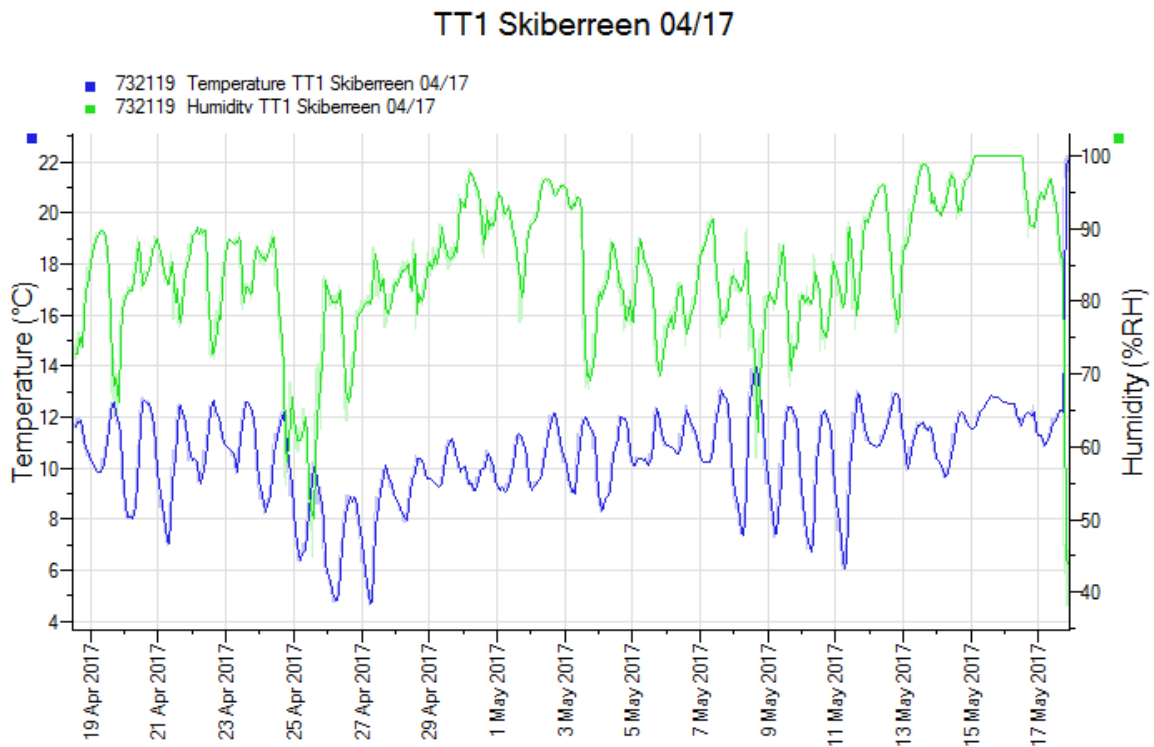

Appendix 26 – Church Energy Usage Questionnaire

1. Name of the Church:

2. Date visited:

3. Address:

4. GPS coordinates:

5. Phone numbers:

6. Contact Person:

6.1. Archbishop

6.2. Dean

6.3. Bishop

6.4. Administrator

7. Location:

7.1. Urban

7.2. Rural

8. Date built:

9. Insulation:

9.1. Location

9.2. Type

10. Construction:

10.1. Walls

10.2. Roof

10.3. Floors

10.4. Windows

10.5. Steeple / Tower

10.6. Bells

10.7. Transepts

11. Crypt:

Yes / No

12. Size of church:

12.1. **Nave:** Length:

Width:

Height:

12.2. **Transepts:** Length:

Width:

Height:

12.3. **Crypt:** Length:

Width:

Height:

13. Uses of the building:

14. People using the building each year:

14.1. Summer

14.2. Winter

15. Religious services each day:

16. Seating Capacity:

17. Opening times:

17.1. Summer

17.2. Winter

18. Employees:

18.1. Part -time

18.2. Full time

18.3. Administrative

18.4. Clergy

18.5. Volunteer

19. Artefacts requiring controlled environment:

19.1. Organ

19.2. Paintings

19.3. Wall Coverings

19.4. Books

19.5. Bells

19.6. Others

20. Heating system:

20.1. Type:

LPHW / HPHW / HVAC / Central Heating / Local heating

20.2. Fuel used:

Gas / LPG / Fuel Oil / Solid Fuel / Electricity / Solar / Heat Pumps / Geothermal / Other

21. Heat emitters:

21.1. Radiant

Electricity / Gas / Radiators / Pew heating / Local Heating

21.2. Boiler

Make / Age / Output / Location / Capacity / Service

22. Heating controls:

23. Fuel storage:

Type (i. e. material of which the storage tank is made)

24. Amount spent per annum on energy use:

Oil / Gas / Electricity / Water / Maintenance / Contract services / Other

24.1. Total annual expenses:

25. Units used per annum:

Gas / Electricity / Oil / Other

26. Windows:

Single Glazed / Double Glazed / Secondary glazing

27. Notes:

Appendix 27 – List of Active Cathedrals in Ireland

Town / City	Name of Cathedral	Date built	Size approx. (m ³)	Fuel used	Heating type	Number of services / year	Boiler details
ROMAN CATHOLIC CHURCH							
Armagh	St. Patrick's cathedral	1873	37,000	Oil	LPHW	520	Elco Klockner Tyron 3 Mk. Burner: Riello RL44
Ballaghaderren	Cathedral of the Anunciation of the Blessed Virgin Mary and St. Nathy	1860	12,250	Oil	LPHW	832	N/A
Ballina	St. Muredach's cathedral	1892	13,500	Gas	LPHW	780	N/A
Belfast	St. Peter's cathedral	1866	15,000	Gas	Under floor	416	CR Remeha Quinta pro
Carlow	Cathedral of Assumption	1833	9,000	Gas	LPHW	780	N/A
Cavan	Cathedral of St. Patrick and St. Felim	1942	17,500	Oil	LPHW	416	N/A
Cobh	St. Coleman's cathedral	1919	38,000	Oil	Under Floor	800	Do Dietrich RBL. Burner: Riello RL44 977T D2W
Cork	Cathedral of St. Mary and St. Anne	1808	13,000	Gas	Hot air / LPHW	416	Radiant heaters & gas air blower
Dublin	St. Mary's Pro Cathedral	1825	25,000	Gas	LPHW	1,560	Tasso
Ennis	Cathedral od St. Peter and St. Paul	1843	7,300	Oil	LPHW	416	Hogfors 20 Nova. Burner: Riello B10
Enniscorthy	St. Aidan's cathedral	1945	15,000	Oil	LPHW	260	Buderus Logano GE315. Burner Riello RL44 B10
Town / City	Name of Cathedral	Date built	Size approx. (m ³)	Fuel used	Heating type	Number of services / year	Boiler details

Galway	Cathedral of Our Lady Assumed into Heaven and St. Nicholas	1965	44,000	Gas	Underfloor	1,144	N/A
Kilkenny	St. Mary's cathedral	1857	13,500	Gas	Underfloor & LPHW	260	N/A
Killarney	Assumption of the Blessed Virgin Mary	1855	22,500	Oil	Underfloor + LPHW	728	N/A
Letterkenny	Cathedral of St. Eunan and St. Columba	1901	16,000	Oil	LPHW	1,248	N/A
Limerick	St. John's cathedral	1894	32,200	Gas	LPHW	832	DE Dietrich. Burner: bactur
Londonderry/Derry	St. Eugene's cathedral	1873	23,000	Gas	LPHW	1,196	N/A
Longford	St. Mel's	1856 & 2015	22,500	Gas	LPHW + underfloor	468	N/A
Loughrea	St. Brendan's	1902	7,700	Oil	LPHW	728	Chappee NXR3. Burner Riello RL28
Monaghan	St. Macartan's cathedral	1948	36,000	Gas (Tank)	LPHW + 9 Gas emmitters	156	N/A
Mullingar	Christ the King cathedral	1939	29,000	Oil	LPHW	832	Chappee X 2. Burner Nu Way
Newry	Cathedral of St. Patrick and St. Coleman	1829	41,400	Gas	HVAC?	832	Fermus
Skibereen	St. Patrick's cathedral	1826	5,400	Oil	LPHW	416	Ferrolli GN2N
Sligo	Cathedral of the Immaculate Conception	1874	17,000	Oil	LPHW	416	Buderus G515 (Main). Ferrolli (Small)
Thurles	Cathedral of the Assumption	1879	15,500	Oil	LPHW	780	N/A

Town / City	Name of Cathedral	Date built	Size approx. (m³)	Fuel used	Heating type	Number of services / year	Boiler details
Tuam	Cathedral of the Assumption	1837	14,500	OIL	LPHW	520	N/A

Waterford	Cathedral of the Most Holy Trinity	1893	17,700	Gas	LPHW	780	N/A
CHURCH OF IRELAND							
Armagh	St. Patrick's cathedral	1837	12,000	Oil	LPHW	780	Potterton commercial NXR3. Burner: Riello RL28
Belfast	St. Ann's cathedral	1981	37,000	Electricity	Radiant heaters	1,040	Electric radiant
Cashel	St. John the Baptist and St. Patricks Rock	1788	3,500	Oil	LPHW	364	Ferroli GN1 No.8 103KW.
Cavan/Kilmore	St. Fethlimidh's cathedral	1860	4,000	Oil	LPHW	104	Ferroli
Clogher	St. Macartan`s cathedral	1744	2350	Electricity	Under pew	104	Electric pipe heating below and in front of pews
Clonfert	St. Brendan`s cathedral	1167	2,700	Elect.	Radiant	4	Electric radiant heaters
Cloyne	St. Coleman's cathedral	1172	12,000	Elect.	Storage	52	Electronic night storage heaters
Cork	St. Fin Barre's cathedral	1870	19,400	Gas	Trench and underfloor	676	Haworthy Warmwell. Haworthy Purewell.
Downpatrick	Down cathedral Holy and undivided Trinity	1818	9,700	Oil	LPHW	156	Chappee
Dromore	The Cathedral Church of Christ The Redeemer	1899	4,500	Oil	LPHW	208	RG5F024/03 TS10/15. Burner: Riello 5305E
Dublin	St. Patrick`s cathedral	1254	35,000	Gas	LPHW	988	5 X Buderuss-Logamax Plus GB162. Controller: Buderus
Town / City	Name of Cathedral	Date built	Size approx. (m³)	Fuel used	Heating type	Number of services / year	Boiler details
Dublin	Christ Church cathedral	1172	17,000	Gas	LPHW	1.092	District heating system
Enniskillen	St. Macartin`s cathedral	1842	3,800	Oil	Hot air	156	N/A

Ferns	St. Edan`s cathedral	1577	1,660	Oil	Hot water pipes	52	N/A
Kildare	The Cathedral Church of St. Brigid	1686	7,500	Gas (tank)	LPHW	52	Chappee. Burner: Riello RS33
Kilfenora	St. Fachtna	1189	1,060	electricity	Underfloor	3	N/A
Kilkenny	St. Canice`s cathedral	1270	35,000	Gas	LPHW	156	Chappee. Burner: Riello RS38
Killala	Cathedral Church of St. Patrick	1680	2,025	Gas (cylenders)	LPHW under pew	24	N/A
Killaloe	St. Flannan's Cathedral	1225	4,140	Oil	LPHW	52	N/A
Limerick	St. Mary's Cathedral	1195	22,500	Gas	Underfloor	416	N/A
Lisburn	Christ Church Cathedral	c1804	5,300	Oil	LPHW + radiant	156	SIME PMO 2R8
Lismore	St. Carthage's Cathedral	c1687	4,300	Elect.	Radiant	156	Electric radiant heaters
Londonderry/Derry	St. Columb's Cathedral	1633	10,000	Gas	LPHW under pew blower	208	Remeha P420
Old Leighlin	St. Laserian's Cathedral	c1290	1,600	Oil/ASHP	LPHW / Cavity AS heat pump	52	N/A

Town / City	Name of Cathedral	Date built	Size approx. (m³)	Fuel used	Heating type	Number of services / year	Boiler details
Raphoe	St. Eunan's Cathedral	c1738	2,195	Oil	LPHW	104	N/A
Rosscarbery	St. Fachtna's cathedral	c1612	3,200	Oil	LPHW	364	Hodfors Lampo OY 482
Sligo	Cathedral of St. Mary the Virgin and St. John the Baptist	1961	4,000	Oil	LPHW	52	Remeasurt L 284
Trim	St. Patrick's Cathedral	1955	2,416	Oil	LPHW	52	N/A

Tuam	St. Mary's cathedral	1878	8,000	Oil	LPHW	52	Chappee NXR35. Burner: RL38
Waterford	Christ Church Cathedral	1792	11,000	Gas	LPHW underfloor	156	N/A

Source of all dates: Galloway, 1992.